

COD REPORT **CR-97/038**



DEPARTMENT OF TRANSPORT

**Design and implementation
of speed humps:**
Supplement to National Guidelines for Traffic Calming

March 1997

TITLE/TITEL DESIGN AND IMPLEMENTATION OF SPEED HUMPS			
REPORT NO. VERSLAG NR.	ISBN	DATE SUBMITTED DATUM VOORGELê	REPORT STATUS VERSLAGSTATUS:
CR-97/038		March 1997	Project
RESEARCH NO. / NAVORSINGSNR:			
CARRIED OUT BY: GEDOEN DEUR:		COMMISSIONED BY: OPDRAGGEWER:	
Division of Roads and Transport Technology CSIR P O Box 395 PRETORIA 0001		Director General: Transport Department of Transport Private Bag X193 PRETORIA 0001	
AUTHOR(S): OUTEUR(S):		PUBLISHER: UITDEWER:	
I Emslie		Department of Transport Directorate: Research Private Bag X193 PRETORIA 0001	
SINOPSIS:		SYNOPSIS:	
<p>Hierdie verslag stel riglyne voor om plaaslike owerhede en verkeersingenieurs by te staan met 'n eenvormige benadering tot die aanwending van spoedhobbels. Dit word aanbeveel dat hierdie riglyne saam met die "National Guidelines for Traffic Calming" gelees word.</p> <p>Konsepte en beginsels wat met die gebruik van spoedhobbels vir spoedvermindering en verkeerskalmering verband hou, word bespreek. 'n Implementeringsprosedure, wat op die standaardisering en stroombelyning van die implementeringsproses gemik is, word aangebied. Die toepaslikheid van spoedhobbels word bespreek en regverdigingsnorme vir die gebruik daarvan, word voorsien. Standaard afmetings en spasierings word voorsien om 'n konsekwente ontwerpstraktyk aan te moedig.</p>		<p>This report presents guidelines to assist local authorities and traffic engineers with a uniform approach to the implementation of speed humps. It is recommended that these guidelines be read in conjunction with The National Guidelines for Traffic Calming.</p> <p>Concepts and principles relating to the use of speed humps as speed reducing and traffic calming measures are discussed. An implementation procedure, aimed at standardising and streamlining the implementation process, is presented. The suitability of speed humps is discussed, and warrants for their use are provided. Standard dimensions and spacings are provided to encourage consistent design practice.</p>	
KEY WORDS TREFWOORDE		Speed humps, semi-circular, trapezoidal, speed cushion, spacing, implementation procedure, warrants, signing and road markings, drainage	
COPYRIGHT KOPIEREG		REPORT COST VERSLAGKOSTE	
Department of Transport, except for reference purposes Departement van Vervoer, behalwe vir verwysingsdoeleindes		R	

DISCLAIMER

The views and opinions expressed in this report are those of the author and do not necessarily represent Department of Transport Policy.

The Department of Transport does not accept liability for the consequences of application of the findings expressed in this report.

REVIEW STATEMENT

This report has been reviewed internally by the CSIR but not by the Department of Transport.

LIST OF CONTENTS

	<u>Page</u>
1. Introduction	1-1 - 1-2
2. Speed hump concepts and philosophies	2-1 - 2-7
2.1 Background	2-1
2.2 Road hierarchy	2-3
2.3 Impact of speed humps on various types of vehicle	2-4
2.4 Problems associated with speed humps	2-5
2.5 Warning and visibility	2-6
2.6 Involvement of the public and affected parties	2.7
3. Implementation procedure	3-1 - 3-6
3.1 Initiation of implementation process	3-1
3.2 Problem identification and subjective assessment	3-1
3.3 Identifying road category	3-3
3.4 Information gathering	3-3
3.5 Suitability of speed humps	3-4
3.6 Warrants for speed humps	3-5
3.7 Design phase	3-5
3.8 Consultation with affected parties	3-5
3.9 Construction of speed humps	3-6
3.10 Monitoring	3-6
4. Warrants for speed humps	4-1 - 4-2
4.1 Series of speed humps	4-1
4.2 Single speed hump	4-1

5.	Design of speed humps	5-1 - 5-6
5.1	Speed hump dimensions	5-1
5.2	Spacing	5-4
5.3	Positioning	5-4
5.4	Signage and markings	5-5
6.	Conclusions	6-1 - 6-2
7.	References	7-1 - 7-1
	Appendix A : Road class classification	A-1 - A3
	Appendix B : Traffic signs and road markings for speed humps	B-1 -B-7

LIST OF TABLES

		<u>Page</u>
Table 2.1	Decision sight distance on level roads	2-7
Table 5.1	Height of semi-circular speed humps	5-2
Table 5.2	Spacing between speed humps	5-4

LIST OF FIGURES

		<u>Page</u>
Figure 2.1	Speed hump versus speed bump	2-2
Figure 2.2	Round top and flat top humps	2-3
Figure 2.3	Speed cushion	2-5
Figure 2.4	Drainage Gap	2-6
Figure 3.1	Implementation procedure	3-2
Figure 5.1	Standard circular round top speed hump	5-1
Figure 5.2	Layout of standard round top speed hump	5-2
Figure 5.3	Sinusoidal speed hump	5-3
Figure 5.4	Layout of a flat top speed hump	5-3
Figure 5.5	Traffic signs and road markings for speed humps	5-5
Figure 5.6	Advisory speed sign and danger plates	5-5
Figure 5.7	Traffic signs and road markings for pedestrian crossings	5-6

1. INTRODUCTION

The Division of Roads and Transport Technology (DRTT), CSIR, receives on a regular basis requests for information pertaining to speed humps and their implementation. These requests are received from developers of both private and public developments, and local authorities. From the number of requests being received, the need for specific design guidelines for the implementation of speed humps has been recognised.

Speed humps have become a popular tool for the traffic engineering and management fraternity to attempt to combat the negative impacts of traffic. This popularity can be attributed to the recognised successful functionality of speed humps as speed reducing devices and their appropriateness under other particular circumstances, where other traffic calming/speed reducing measures are not appropriate. An additional factor adding to their popularity is the relatively low cost associated with the installation of speed humps. Unfortunately, it is not uncommon for some developers and local authorities to assume that the implementation of speed humps is a rudimentary exercise. Speed humps, of incorrect geometric dimensions and layout are often installed in inappropriate circumstances without considering the overall impact of implementation on both localised traffic and traffic within the surrounding road network. Particularly in cases where speed humps have been installed on residential access roads and local distributors, the inappropriate installation of humps has often resulted in either a shifting of the problems of speeds experienced onto adjacent streets or a worsening of the problems at the actual site itself.

The aim of this document is to provide guidelines aimed at a uniform approach to the implementation of speed humps. In instances where a greater understanding of the principles of traffic calming are required these guidelines should be read in conjunction with the National Guidelines for Traffic Calming. The document deals specifically with the larger 3,7m long speed hump, typically between 80 and 120mm high, and not with the smaller 0,5m long speed bump that is typically between 100 and 150mm in height. The smaller speed bumps are not suitable for use on public roads, and are therefore only recommended for shared space environments.

The objectives of these guidelines are to:

- give an overview of the concepts and philosophies behind the implementation of traffic calming;
- provide a procedure which local authorities and developers can follow when deciding on the implementation of speed humps;
- indicate the relevant limitations of and warrants for speed humps;
- outline the various types of speed hump and the possible modifications, in order to achieve the desired results;

- provide standardised dimensions, layouts, spacings and other design criteria that are associated with speed humps; and
- highlight the need for monitoring their effectiveness after implementation.

The DRTT undertook to produce these guidelines as part of their ongoing investigation into traffic calming. The guidelines are based on both local and overseas experiences. Layout and dimension details provided serve as a basis for design, although it is important that sound engineering judgement be applied.

2. **SPEED HUMP CONCEPTS AND PHILOSOPHIES**

This chapter addresses a number of issues and principles that need to be considered by planners and engineers before they proceed with the design and implementation of speed humps. These issues are not discussed in great detail, but are briefly highlighted to bring them to the attention of those involved with the design and implementation processes. These issues are discussed in more detail in the National Guidelines for Traffic Calming and other literature covering traffic calming, in both the South African and overseas context.

2.1 **Background**

Requests for speed humps are primarily motivated by the need to restrict speeds along a particular road, or at a particular site, to safe and desirable levels, and to discourage the use of a particular road by through traffic. In the 'shared space' environments (eg car parks, pedestrianisation schemes etc.) the need to protect pedestrians and other vulnerable road users has also prompted the use of speed humps.

Research, both locally and overseas, has shown that speed humps, if constructed to the appropriate dimensions and spaced correctly, are effective in reducing and limiting the speeds of vehicles. Speed humps are designed so that vehicles may comfortably negotiate the hump at a predetermined speed that is considered both desirable and safe for a particular set of circumstances, while causing increasing discomfort when negotiated at higher speeds. Spacing of consecutive speed humps has an influence on the speed that vehicles may attain between humps, and therefore, if correctly spaced, can limit the maximum speed a vehicle can attain along a road segment.

Although there is no material evidence to suggest that speed humps in isolation effectively limit extraneous traffic from a particular road or route, it is believed that a series of speed humps along a route, and with adequate alternative routes available, can play a significant role in route choice. However, when speed humps are placed along an isolated route, careful consideration must be given to the potential shifting of traffic onto adjacent streets. In such situations it is recommended that an area-wide approach be adopted¹.

Another advantage of speed humps is their positive effect in reducing accidents in certain situations, particularly at sites where a combination of excessive speeds and the geometric layout play a major role in the cause of accidents.

Speed humps have also proven to be effective when implemented in conjunction with other traffic calming devices or as part of a traffic calming scheme. Their recognised speed reducing capability can be used to assist other devices in achieving a desired influence on traffic characteristics more effectively. They are commonly used in conjunction with mini-circles and pedestrian crossings and the principles of speed humps are evident in raised intersections and thresholds treatments.

In the past, smaller speed bumps, typically 0,5m in length and between 100 and 150mm in height, were constructed. They were initially believed to be effective in reducing speed, but research in Australia, the U.K. and the U.S.A. has shown that these types of speed hump actually rewarded speedsters, encouraging motorists to negotiate them at high speeds in order to decrease noticeability and discomfort. They also caused serious damage to vehicles if constructed too high, and were particularly severe on two wheeled vehicles.

Local and overseas research has indicated that the ideal speed hump should be approximately 3.7m in length and between 70 and 120mm in height, depending on the desired severity of the hump. If shorter, they are too severe and if longer they are more easily negotiable by typical passenger cars. Figure 2.1 gives a graphical representation, showing the relative size of the speed bump compared with the more favourable speed hump. Speed humps are appropriate on public roads and bumps on private property where design and operating speeds are low (<30 km/h).

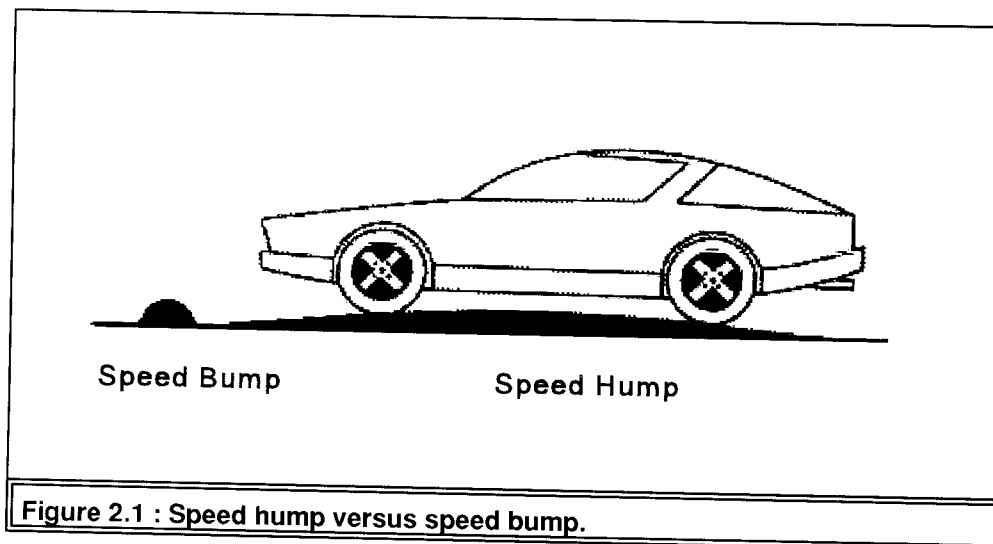

The round top (semi-circular) and the flat top (trapezoidal) speed humps are the most common. Both have proved successful in reducing speeds. The flat top hump usually incorporates a pedestrian crossing on the 'table top' of the hump. Figure 2.2 illustrates these two types of hump. Other modifications of speed humps included the speed cushion (see 2.3) and the raised intersection, but these are discussed in more detail in The National Guidelines for Traffic Calming.

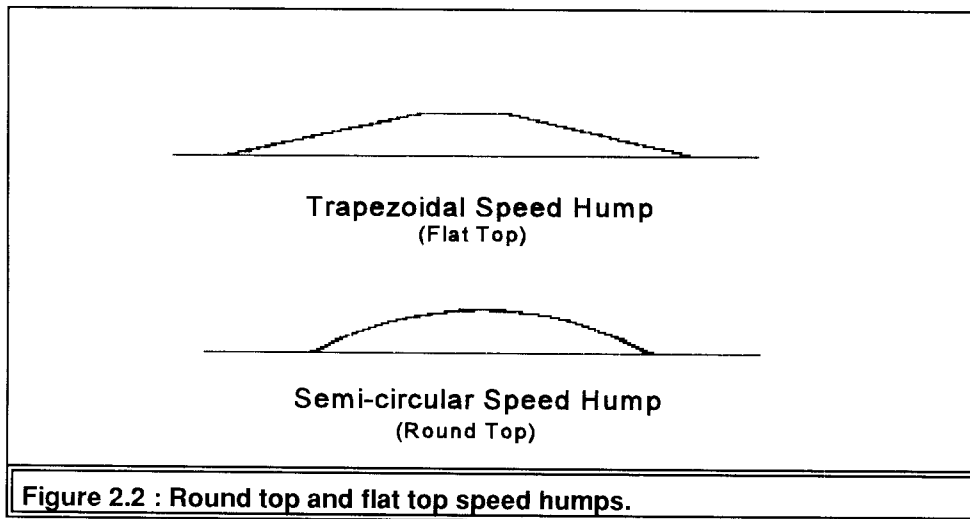

2.2 Road Hierarchy

The road hierarchy is broken down into 5 basic road categories (see Appendix A). Class 1, 2 and 3 roads are national, regional and district distributors, and their primary function is to provide mobility. Class 4 roads are local distributors, providing both mobility through and access to local residential and business areas. Class 5 roads have as their primary function access within a residential area. The intended road hierarchy is determined during the design phase of the road network, but as traffic characteristics and demands change, the road hierarchy evolves and the intended functions of particular roads change. It is essential that the functional road hierarchy, and desired street function, are identified and defined before proceeding with the planning phase. In assessing the potential impacts that the implementation of a single or series of speed humps might have on the local road network, it is suggested that an area wide approach be employed.

Speed humps, particularly in isolation, are not suitable on roads carrying high volumes of traffic and on roads where the acceptable speed of the majority of vehicles is above a certain level. The safety risks associated with vehicles braking suddenly from high speeds, the potential damage that can be inflicted on a vehicle (and the safety implications) when a speed hump is negotiated at high speeds, and the undesirable effect that speed humps have on mobility, make them applicable only on lower order roads, where mobility is not the primary function of the road.

On roads where mobility is the primary function (Class 4 roads and above), the use of speed humps is not recommended. Under no circumstances should they be considered for use on class 1, 2 or 3 roads, and only under certain circumstances should they be considered on class 4 roads. Speed humps should be considered where the potential for pedestrian/vehicle conflicts or accidents is high or where pedestrians are particularly vulnerable (in the vicinity of schools, playgrounds and old age

homes). It is common for speed humps on class 4 roads to have a higher design speed and therefore be less severe than those on local residential access roads. This is to maintain an acceptable degree of mobility and prevent unnecessary discomfort amongst motorists.

2.3 **Impact of Speed Humps on Various Types of Vehicle**

One of the main problems associated with speed humps is their varied effect on various sized vehicles. For instance, a normal 3.7 metre long 100mm high round top speed hump will be far more severe on a bus or a service vehicle than on a passenger car, having the equivalent effect of a smaller speed bump on a normal passenger car, causing unnecessarily high levels of discomfort to passengers and increasing the likelihood of damage to the bus. Ground clearance of buses and heavy goods vehicles (HGV's) must be considered to avoid the bottom of the vehicle scrapping on the hump (as the wheelbase is longer and will therefore straddle the hump). Likewise a speed hump designed for large vehicle will have a minimal effect on a car. It is therefore recommended that the placement of speed humps on routes frequently used by buses, HGV's and service vehicles should be avoided.

Speed humps can have a major adverse effect on emergency vehicles. Not only do they limit the mobility of emergency vehicles, where speed is often of the essence, but their severe effect on these vehicles is undesirable in emergency situations. Therefore, it is strongly recommended that, wherever possible, speed humps should not be constructed on routes frequently used by emergency vehicles or on routes designated as emergency routes. On residential roads, not in the vicinity of emergency facilities, the positive impacts of speed humps should take precedence over the requirements of rare events.

Speed humps can prove potentially dangerous to two wheeled vehicles, such as bicycles and motorcycles, since control of the vehicle is adversely affected when the speed hump is negotiated. It is common for a gap to be left between the speed hump and the kerb for drainage purpose, and this gap, if too narrow, can also prove dangerous for cyclists if they wrongly perceive it to be a cycle gap. It is common practice overseas to provide a separate cycle lane.

A modification of the speed hump, the speed cushion, is a possible solution to accommodate larger vehicles and two-wheeled vehicles. With the exception of width, speed cushions should be identical to speed humps with respect to dimensions. The concept behind speed cushions is that the width should be such that normal passenger cars have to negotiate the speed cushion while wide axle-width vehicles remain unaffected. Unfortunately this is not always possible, because the distance between the inside wheels on the rear axles of larger vehicles and the dimension of some smaller emergency vehicles, often results in the speed cushion still having an impact on these vehicles. A common solution to this problem is for the sides of the speed cushion to be sloped. The large gap

between the speed cushion and the side kerbing means that they have no effect on pedal cyclists or motorcyclists. It is essential that speed cushions in adjacent or opposing lanes are positioned such that normal passenger cars cannot pass between them unaffected. It is recommended that speed cushions are implemented in combination with other traffic calming devices. Fig 2.3 illustrates a typical speed cushion.

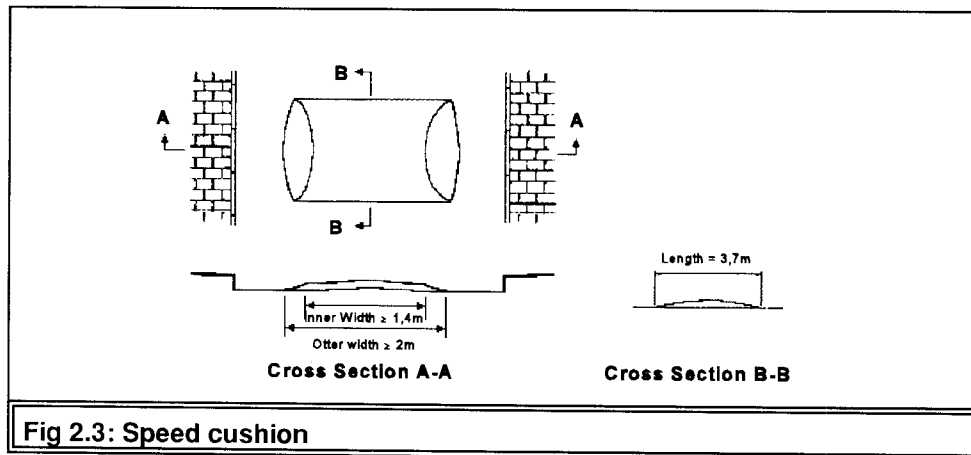

Fig 2.3: Speed cushion

2.4 Problems Associated with Speed Humps

An increase in noise and vibration levels, associated with the accelerating and braking of vehicles, particularly heavy vehicles, will be experienced with the installation of speed humps. These effects will be exacerbated if the speed humps are incorrectly designed and/or incorrectly spaced or positioned on routes frequently used by heavy vehicles. There have also been cases reported where motorists had voiced their disapproval of particular speed humps by needlessly hooting or causing excessive noise when braking before or accelerating away from the speed hump². Although these cases are rare, they highlight the importance of taking the motorists' viewpoint into consideration. It is also particularly important to warn residents in the area of the potential noise implications associated with speed humps.

Although there is speculation that speed humps may have an adverse effect on air pollution, the exact impacts have not been investigated and the increase on pollution levels is unknown. Another disadvantage with speed humps is that some residents consider them unsightly, and this is particularly true if they are not maintained properly. The need to maintain speed humps due to the intense wear and tear they are exposed to, and the associated costs, are further negative implications.

If speed humps are constructed from kerb to kerb (ie. across the entire width of the road), and the kerbing is vertical kerbing, the humps may encourage parking on sidewalks (as they provide access for vehicles on to the sidewalk), thus inconveniencing pedestrians. If speed humps are positioned

adjacent to mountable kerbing, the temptation for motorist to utilise the sidewalk as an 'alternative' to the hump could endanger pedestrians. By strategic placing of bollards or positioning speed humps next to trees, planters and other existing obstacles, this may be prevented.

Drainage is another aspect which needs to be considered in the design of a speed hump. It is essential that speed humps do not cause a 'damming' of water in the vicinity of the hump, as this will not only have major safety implications, particularly for vehicles braking, but could also effectively 'disguise' the speed hump to motorists, particularly at night. A common practice is to leave a gap of between 100 and 200mm between the kerb and the speed hump (see figure 2.4).

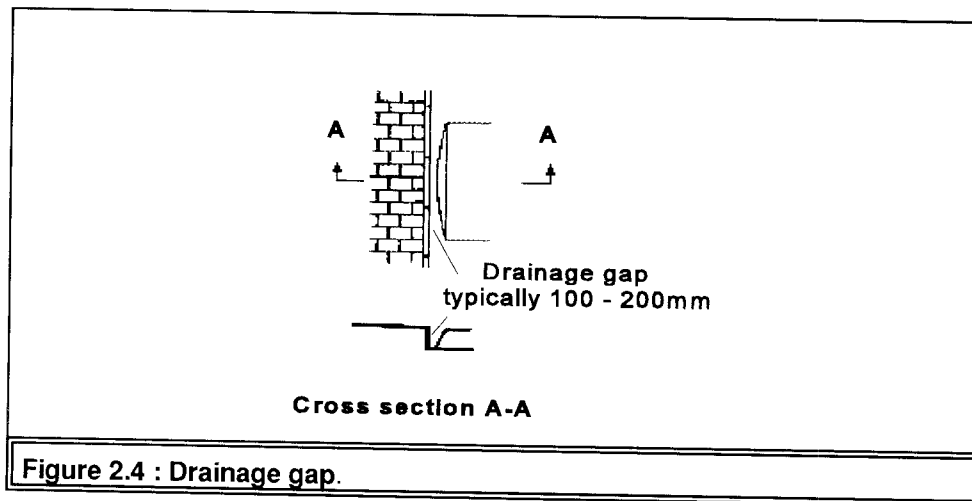

2.5 Warning and Visibility of Speed Humps

Careful attention should be paid to providing adequate warning to motorists of the presence of speed humps. The relevant warning signs and road markings are provided in The South African Road Traffic Signs Manual (see Appendix B). Because of the intense wear that occurs on the road markings on speed humps, and with the common vandalism inflicted on road signs, regular inspection and maintenance are important. Road markings of humps should be with high quality retro-reflective paint with good skid resistance properties. To improve visibility at night and in the wet road studs should be used.

Decision Sight Distance (DSD) is an important criterion to consider when planning the position of speed humps. It is essential that motorists are able to see speed humps well in advance. Table 2.1 gives recommended DSD for particular design speeds. In measuring the DSD, an eye height of 1,05m and an object height of zero should be used³. Speed humps on blind rises, crest or sag vertical curves and on sharp horizontal curves should be avoided.

Table 2.1: Decision Sight Distance on level roads.	
Design Speed (km/h)	Decision Sight Distance (m)
50	135-195
60	170-235
70	200-275
source: UTG1 : Guidelines for the geometric design of urban arterial roads ³	

It is also not advisable to place speed humps on roads with a grade greater than 6%. Not only are there drainage implications in such instances, but there is a danger that motorists descending on the speed hump, due to the angle at which they view the hump, may underestimate the restriction. There is also a danger that at night, the 'damming' of water along the width of a hump may 'disguise' the speed hump. They also have implications for vehicles, particularly heavy vehicles, travelling up the grade, as they usually need to gear down to negotiate the hump, thus causing considerable inconvenience to the drivers and increase noise and emission levels.

It is essential that adequate lighting is provided so that the speed humps are sufficiently visible at night. The exact location of a speed hump may be influenced by the presence of existing lighting, but not to the degree where recommended spacings and DSD are compromised.

2.6 **Involvement of the Public and Affected Parties**

As is the case with all traffic calming measures, the success of a single hump or a series of speed humps depends on their acceptance by local residents and other affected parties. Speed humps are designed to benefit the local residents by providing a safer, more pleasant environment and to reduce the general negative impacts of traffic. However it is essential that residents are informed during the planning phase, with both the potential positive and negative impacts being highlighted. Gaining their approval for the implementation is important so that they accept the consequences of the scheme. If they do not accept the plans, alternative solutions should be investigated in consultation with the affected parties, including the 'do nothing' alternative.

In cases where requests are denied, the affected parties should be informed of the reasons behind the decision. Motorists should also be equally considered in the planning phase, as unreasonable and unnecessary restraints may result in them defeating the success of the implementation.

3. **IMPLEMENTATION PROCEDURE**

The need for an implementation procedure to assess the validity of requests and to determine whether speed humps are warranted or not, has been recognised. This chapter provides a guideline to assist the relevant planners and decision makers in the process. The aim is to provide a uniform and streamlined procedure, which should prevent the incorrect or unnecessary use of speed humps and reduce the need for corrective measures after implementation. It is based on the current speed hump assessment and implementation procedure being adopted by the Cape Town City Council and the 'Warrants for Traffic Calming' outlined in the National Guidelines for Traffic Calming (which are presently being successfully adopted by the Pretoria City Council). It is once again emphasised that, although these guidelines are intended to lead designers through the implementation process, the need for sound engineering judgement is an important component in the application of these guidelines, as each situation is unique.

Figure 3.1 provides a diagrammatic representation of the recommended implementation procedure. The procedure is broken down into eleven steps which are outlined below.

3.1 **Initiation of Implementation Process**

The process is usually initiated by a formal complaint or request from the public or other affected parties. It can also result from the identification of a potentially dangerous site (black spot) or a route operating at an unacceptable volume or speed. Before proceeding, all relevant documents should be collected and the concern of the requesters identified.

3.2 **Problem Identification and Subjective Assessment**

The first step after receiving a complaint or request for speed humps is to identify and assess the problem motivating the request. From the information given in the request, and based on knowledge of the site or route and experience of the present operating levels at the site or along the route, the reasons for the concern should be identified. A subjective decision should then be made as to whether there is a need for further investigation or not. Existing data, such as speed and volume counts and accident statistics should be referred to in making this decision. Site inspections, to observe conditions during the critical time of the day (identified from the request or during the peak period), are recommended to obtain a feel for the circumstances prompting the request.

The purpose behind this step is to quickly determine, from existing knowledge of the site or route, whether further action is warranted with respect to the request. If it is decided that no further investigation is required at a site or along a route, the decision, and the reasons behind the decision, should be communicated to the affected parties.

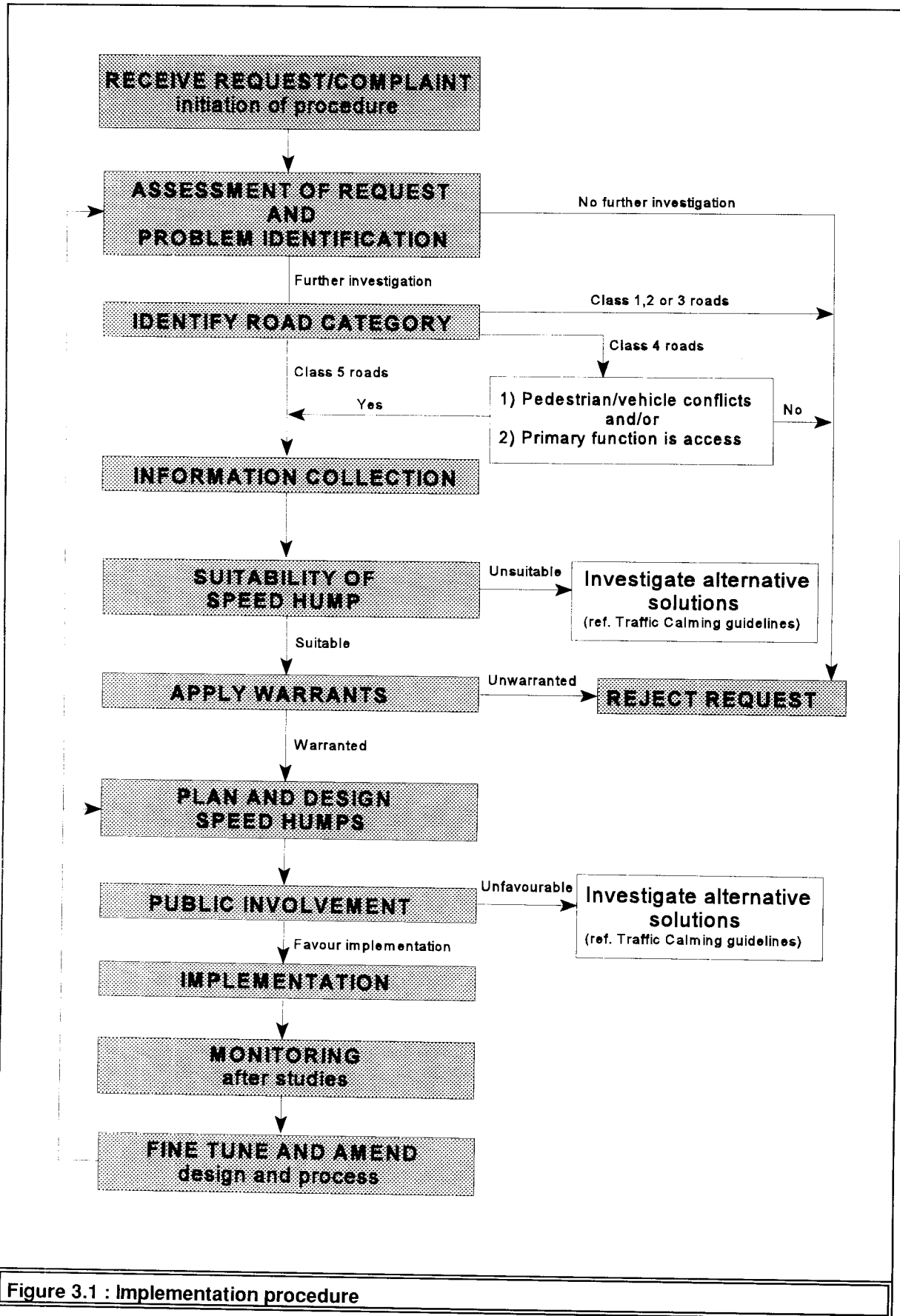

Figure 3.1 : Implementation procedure

Once the fundamental problem has been identified, the basic approach to be adopted must be chosen. If the problem is one of excessive speeds or volumes along a route, the recommended course or action is a series of measures along the route. If the problem is of a local nature, for instance an hazardous site or a pedestrian problem near a school, then the likely approach will be the implementation of a single measure.

3.3 **Identifying Road Category**

The next step is to assess the local road hierarchy and determine the function and category of the road under consideration (see Appendix A). An important aspect is to consider both the planned and functional hierarchy of the road as these may differ. As traffic demand grows, circulation patterns change and these often impact on lower order roads, which may, or may not, functionally fulfill the role of a higher order road.

If the site or route under consideration falls on a class 4 category road, the need to assess the specific set of circumstances is required. If the site is in the vicinity of a school, playground, old age home or any other similar facility, the investigation should be continued. Similarly, if the desired function of the road is more accessibility than mobility, the investigation should be continued. If neither of these are true, then the request should be rejected, with the decision being communicated to the relevant parties.

Speed humps can be implemented on local access roads, and the investigation should be continued.

3.4 **Information Gathering**

Having selected sites, the next phase is the collection of relevant information in order to determine whether speed humps are warranted. Where there are no existing and relevant data, the relevant information should be obtained from limited traffic surveys and site visits.

Data and information regarding the following criteria should be collected;

- Speeds along the route - if there are no existing up to date statistics available then speeds should be measured along the route. It is recommended that these measurements be taken outside the peak hours so as to record typical speeds, not influenced by peak hour volumes. These speed measurements are used to calculate an 85th percentile speed. In order to get a reasonable result, a minimum of twenty random readings in each direction should be recorded.

- Volumes along route - volume counts during the peak hours for two weekdays should be conducted. From these counts an average peak hour volume should be calculated.
- Pedestrian volumes - if the problem concerns the vulnerability of pedestrians, pedestrian counts should be conducted in the vicinity of the problematic site. At schools, these must be performed in the morning and midday/mid-afternoon peaks, when the movement of children is at a maximum.
- Conflict potential - potential conflicts between pedestrians and vehicles should be identified during site visits.
- Accident statistics - if the problem concerns a potentially hazardous site, accident records should be studied to identify reasons for the accidents and associated trends.
- Functional road hierarchy of local road network - the operating levels of the local road network should be obtained from site visits and existing knowledge of the relevant roads.
- Frequency of buses and service vehicles along the route - assessing the relevant schedules should determine whether the route lies on a major bus or service vehicle route.
- Emergency routes - through consultation with emergency services the frequency of application of the route by emergency vehicles should be determined.
- Physical characteristics - layout, horizontal road alignment, grades, drainage and street furniture should be observed from plans and site visits.

If the problem is one of unacceptable speeds along a route there is no need to collect pedestrian volumes or accident statistics unless these specifically benefit the motivation.

3.5 Suitability Of Speed Humps

Before determining whether speed humps are warranted, the suitability of speed humps under the specific set of circumstances should be investigated. Since a number of the criteria used to determine their suitability are qualitative, sound engineering judgement and, where possible, a knowledge of the conditions, should be applied when assessing these criteria. The suitability of speed humps, in series or in isolation, are determined by the following :

- Will the local road hierarchy support the potential impacts on traffic flow resulting from the implementation?
If the implementation has the potential to shift traffic on to adjacent roads that should not or cannot accommodate the increase in volumes, speed humps are not appropriate, and an area wide approach to solving the problem is recommended.
- Is the road frequently used by emergency vehicles, buses, HGV or service vehicles?
If this is the case then the suitability of alternative measures should be investigated¹. If no other more suitable alternative is found, then the negative implications, particularly in the

case of emergency vehicles, should be weighed against the benefits and proceeding with the implementation process should be done with caution.

- Do the physical and geometric characteristics of the site lend themselves to the implementation of speed humps?

If there are any physical restrictions, such as limited decision sight distances or excessive grades, that make the implementation unadvisable, then alternative solutions should be investigated.

3.6 **Warrants for Speed Humps**

The warrants applied depend on the approach to be adopted; either a single hump or a series of humps, and are described in the next chapter.

3.7 **Design Phase**

The design phase follows the evaluation of the suitability of speed humps as a solution to the problem. This evaluation includes checking whether the warrants for speed humps are met. This phase involves:

- the choice of speed hump/s to be used (round top vs flat top);
- the selection of the correct dimensions of the speed hump to achieve a desired effect;
- the spacing between speed humps when a series of humps is to be implemented; and
- the exact positioning of speed humps.

The relevant information and values are discussed in chapter 5.

3.8 **Consultation with Affected Parties**

Once a plan for the implementation has been formalised, and the designs drafted, the local residents and other affected parties should be informed of the proposed action. It is important to communicate the reasons behind decisions, to highlight both the potential benefits and negative impacts, and to discuss their specific concerns surrounding the planned implementation.

If the residents and affected parties accept the proposed plans, the implementation can commence. Where there is significant concern or rejection of the plans, alternative solutions should be investigated in consultation with the affected parties.

Once the implementation plans are approved, and before construction begins, appropriate steps

to warn motorists of the intention to implement a speed hump/s along the particular route are recommended. The local press and radio stations should be used to inform the public of the plans and the relevant dates.

3.9 **Construction of Speed Humps**

If the construction is not carried out Departmentally, the usual tender procedures, adopted by the local authority, should be followed. It is essential during the construction phase that adequate inspections of the works are carried out to ensure that the speed humps are accurately constructed to the correct dimensions and spacings. Failure to do so could result in the construction of incorrectly spaced and incorrect dimensional speed humps, which could undermine the success of the implementation.

Particular attention must be paid to signing, marking and drainage. It is emphasised that traffic signs and road markings, complying with the recommendations of the South African Traffic Roads Signs Manual must be incorporated, and that in the case of road markings, quality retro-reflective paints be used.

3.10 **Monitoring**

It is necessary to monitor the effects of the speed humps on traffic flow characteristics. This step is essential to determine whether the implementation of the speed humps has been successful in achieving the desired objectives.

'After studies' should be conducted between three and six months after the speed humps were constructed, and the new operating levels should be compared to original conditions to assess the success of the implementation. Unexpected impacts and relevant 'lessons learnt' should be recorded for future reference, and where possible the success of the scheme should be communicated to the affected parties. If any modifications that might improve the operating conditions are identified, they should be investigated and incorporated.

4. **WARRANTS FOR SPEED HUMPS**

To prevent the unnecessary placement of speed humps, the following warrants are recommended. The warrants to be adopted depend on the chosen implementation approach.

4.1 **Series of Speed humps**

Where speeds and/or volumes are of concern and the likely approach to be adopted is a series of speed humps along a route, speed humps are warranted if:

- the 85th percentile speed exceeds the desired speed (40 to 80 km/h); and/or
- the average peak hour volume exceeds between 400 and 600 vph (depending on the desired nature of the road).

4.2 **Single Speed Hump**

If a single speed hump is to be implemented, the warrants to be adopted depend on the motivation for the speed hump; either a hazardous location or a pedestrian/vehicle conflict. In both cases it is important to note the restriction(s) applicable to the installation of a single hump, as given below:

Hazardous Site or Location

If the problem motivating the concern is a potentially hazardous site or location then the placing of a speed hump in the vicinity of the site to improve the conditions is warranted if:

- the number of accidents in the vicinity of the site exceeds 3 in one year; and
- speed is a common dominating factor contributing to the cause of the accidents.

Pedestrian/vehicle Conflict

Where the potential conflict between pedestrians and motorists is of concern along the particular road, then a speed hump (in isolation) is warranted if:

- the road provides access to a school, playground or old age home and the number of pedestrians, predominantly children or the elderly, crossing the road along its length exceeds 150 pedestrians in the peak pedestrian hour (a value of 50 is recommended in the case of old age homes).
- the unbroken road width is greater than 10 m and traffic volume greater than 400 vph.

If the pedestrians crossing the road are predominantly average (ie not children or elderly) then the Pedestrian Facility Guidelines should be referred to.

Restrictions on Single Speed Humps

If the approach to be adopted involves an isolated speed hump, then:

- the 85th Percentile speed may not exceed 70 km/h; and
- the peak hour volume must be less than 600 vph.

Failure to meet these requirements suggests that either a series of speed humps should be considered or an alternative solution should be investigated.

5. **DESIGN OF SPEED HUMPS**

This chapter provides the relevant information required for the design and positioning of speed humps. The dimensions given are based on local and overseas experience and have proven effective. The relevant road signs and markings for speed humps as recommended in the South African Roads Traffic Signs Manual are also provided.

5.1 **Speed Hump Dimensions**

There are two recognised speed humps; the round top (or semi-circular) speed hump and the flat top (or trapezoidal) speed hump. They are equally effective in reducing speeds if correctly designed. Their construction is similar, although trapezoidal humps made from interlocking paving blocks are easier to construct than round or flat top humps made from asphalt. The costs of construction are generally higher for flat top humps, due to the greater amount of construction material required. Semi-circular humps are, therefore, more popular for general use. Because of their suitability in accommodating pedestrian movement, flat top humps are commonly used at pedestrian crossings. With minor modifications to make them less severe, trapezoidal humps can also be equally effective for both normal passenger cars and heavy vehicles, and they are therefore recommended for situations where limited bus, HGV and emergency vehicle movement occurs. Speed cushions could also be considered in these cases (although it is recommended that speed cushions are used in combination with other traffic calming devices).

Semi-circular speed hump.

Figure 5.1 shows the typical cross section of a standard semi-circular speed hump. The height of the semi-circular hump is determined by the maximum desired speed at which normal passenger cars can comfortably negotiate the measure. Table 5.1 gives the corresponding heights for the desired maximum speed. The length of the hump should range between 3.6 and 4 metres (typically 3.7m). It is important that the hump is anchored by two ridges running perpendicular to the flow direction across the entire width of the hump.

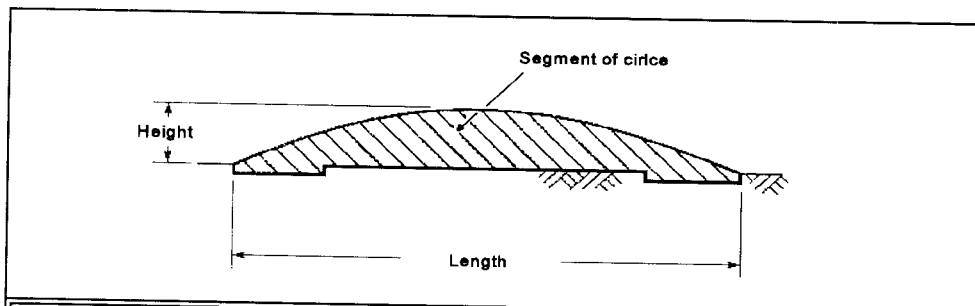
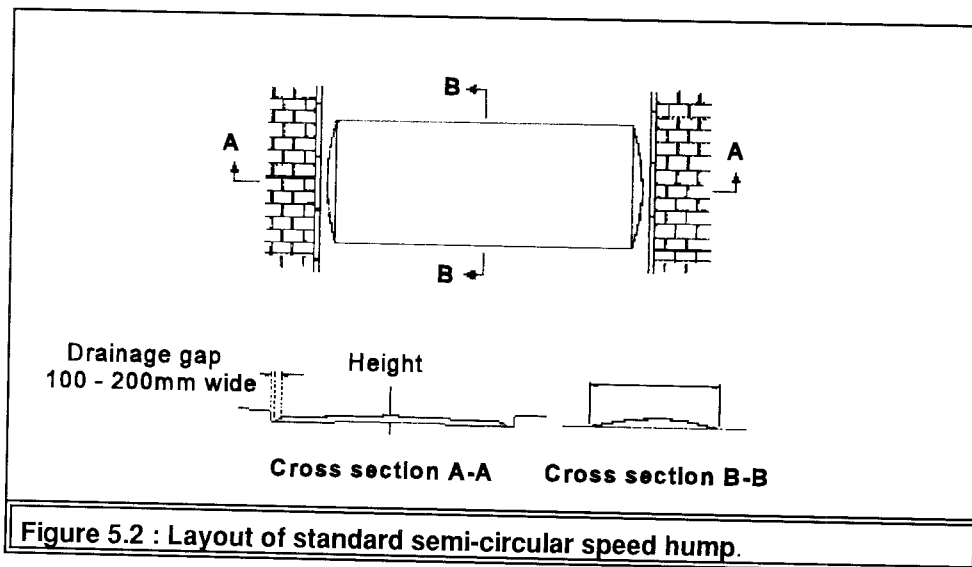

Figure 5.1 : Standard semi-circular (round top) speed hump.

Table 5.1 : Height of semi-circular speed hump.	
Desired Maximum Speed over hump (km/h)	Height (mm)
30	120
40	100
50	80
source: National Guideline for Traffic Calming	

Figure 5.2 shows the layout of a standard round top hump. It is common practice to leave a gap on either side of the hump for drainage purposes. Kerbing should preferably be vertical or alternatively bollards or similar obstructions will need to be placed on the verges to stop motorists from avoiding the hump by driving on the adjacent pavement.



Another type of round top speed hump recommended in The National Guidelines for Traffic Calming is the Sinusoidal Speed Hump. Figure 5.3 gives the typical dimensions for such a hump, but due to the precise accuracy required when constructing these humps, they are not commonly chosen. They have also not been evaluated in this country and if selected, this must be taken into account.

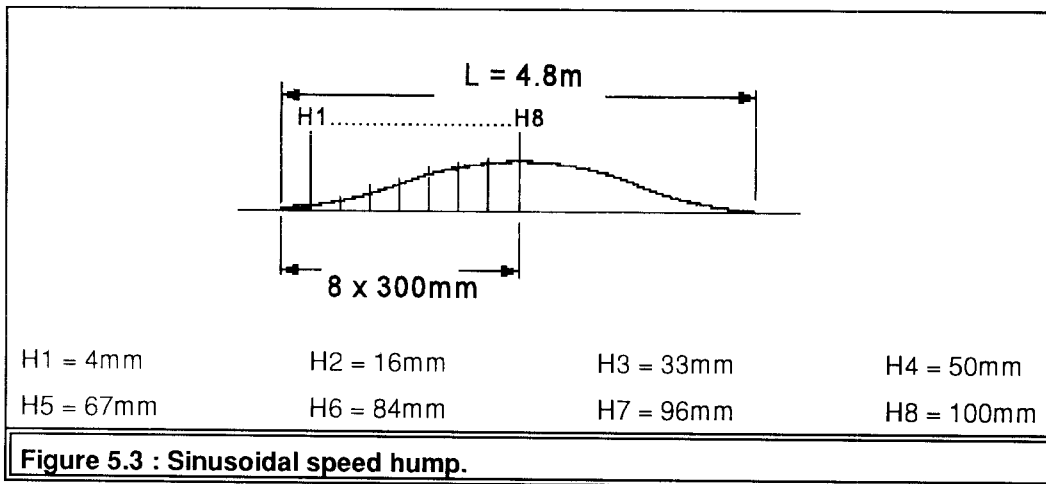

Trapezoidal speed hump.

Figure 5.4 shows the layout and cross sections of a standard trapezoidal speed hump. The height of a trapezoidal speed hump should be between 100 and 120mm, depending on the desired severity. The length of the 'table top' should range between 2 and 2.4 metres with the pedestrian crossing across the top, and the total length should vary between 5 and 12.4 metres. The gradient of the ramps of a trapezoidal hump should be between 1:15 and 1:40, relative to the gradient of the street on which it is built.

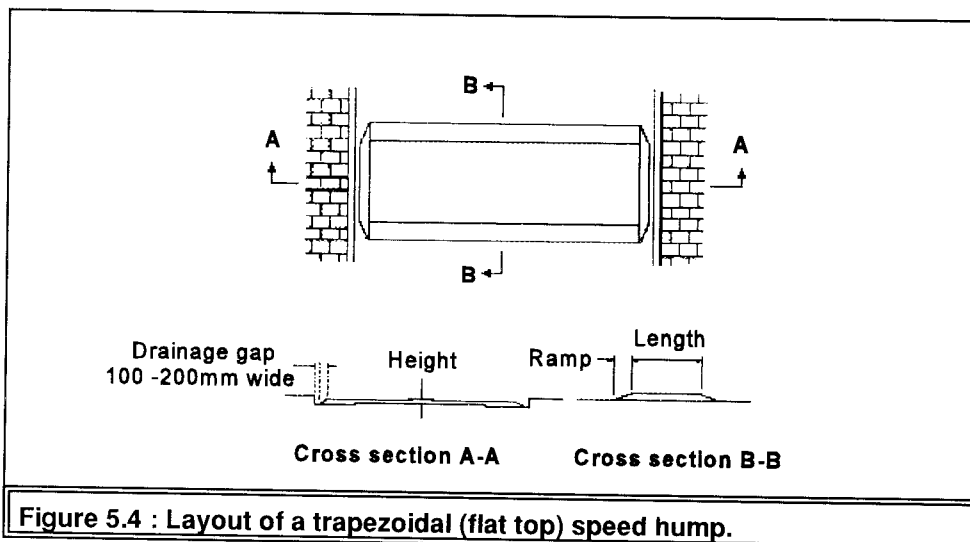

If the speed hump is to be predominantly traversed by normal passenger cars, and not by long heavy vehicles, the hump should be designed with ramp gradients of 1:15. If consideration is to be given to long heavy vehicles, then the severity should be minimised and ramp gradients of 1:40 with

a maximum height of 100mm, provided.

5.2 Spacing

If a series of humps is to be implemented, the spacing between humps is determined by the desired maximum speed midway between humps. These spacings are based on the following equation¹:

$$\text{Distance btw. humps (m)} = (\text{maximum desired speed btw. humps (km/h)} - 30) \times 10$$

Table 5.2 gives the recommended spacing for maximum desired speeds between humps. Speed humps should not be spaced closer than 50 metres. When speed humps are to be placed in the vicinity of an intersection, they should not be placed within a distance of 8 metres from the intersection, unless they support other calming measures at the intersection (e.g. mini-circle). When pedestrian crossings are incorporated on trapezoidal speed humps, it is advisable to place standard semi-circular speed humps at a distance of 50 metres on either side of the trapezoidal hump.

Maximum desired speed between speed humps (km/h)	Spacing (m)
35	50
40	100
45	150
50	200

source: National Guidelines of Traffic Calming

The intention in selection of the spacing of successive humps is that the actual speed between humps should be similar to that used in traversing them. Irregular spacing is not recommended as this creates inconsistent design practice and will create frustration with drivers.

5.3 Positioning

Although the positioning of speed humps is determined by the recommended spacing, the exact location of a speed hump must take cognisance of existing physical characteristic of the site. The presence of drainage facilities, street lights and other relevant street furniture should influence the location of speed humps, as long as it does not compromise the ideal spacing significantly. In the

case of pedestrian crossings the speed hump should be positioned according to the pedestrian desire lines, determined in accordance with the procedures described in the Pedestrian Facility Guidelines. The positioning of speed humps should also comply with Decision Sight Distances (Table 2.1) requirements at the particular speeds.

5.4 **Signing and Markings**

An important aspect in the implementation of speed humps is the need for adequate warning for motorists. The necessary traffic signs and road markings are recommended in the South African Road Traffic Signs Manual (see Appendix B). Figure 5.5 shows the recommended signs and markings. It is also recommended that the speed hump warning sign be used in combination with an Advisory Speed sign (mounted immediately below the warning sign), showing the appropriate speed (design speed) for the specific hump. The traffic sign should be placed 30 metres ahead of the speed hump. The placing of 'Danger Plates' (W401 and W402) on either side of the hump is also recommended. Figure 5.6 illustrates the Advisory Speed sign and the relevant Danger Plates.

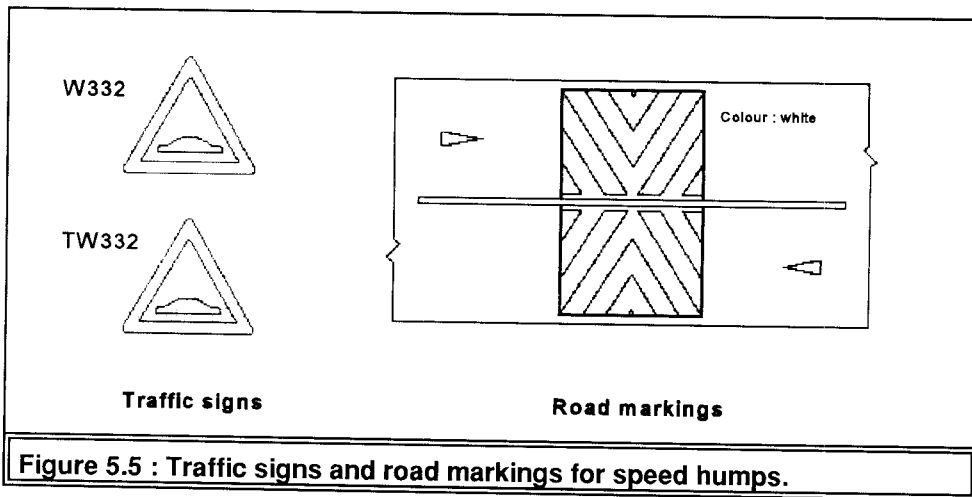

Figure 5.5 : Traffic signs and road markings for speed humps.

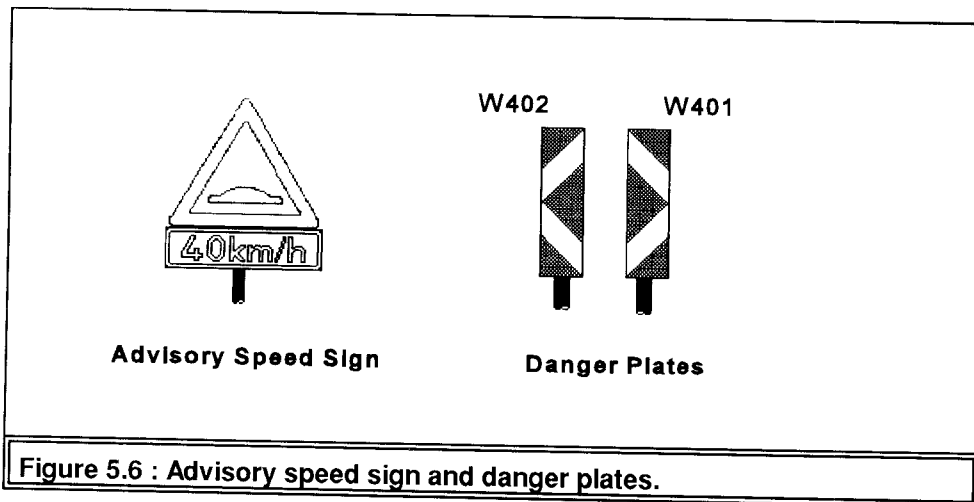
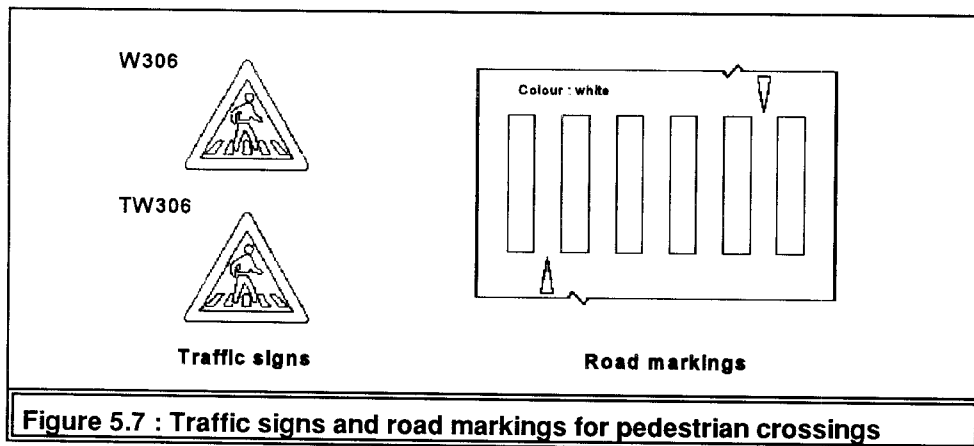

Figure 5.6 : Advisory speed sign and danger plates.

In the case of a trapezoidal hump with a pedestrian crossing on the 'table top', the relevant traffic signs and road markings (zebra crossing) for pedestrian crossings should be installed, in accordance with the signs manual (Figure 5.7).



6. CONCLUSIONS

A summary of the information provided in the report is given below.

- Speed humps, if constructed to the appropriate dimensions and spaced correctly, are effective in reducing and limiting speeds. In isolation their effect on diverting non local traffic is unknown but, in series, speed humps may play a significant role in route choice.
- Speed humps are commonly used in conjunction with other traffic calming devices to enhance their speed reducing abilities. At sites where pedestrian/vehicle conflicts are a problem, trapezoidal speed humps with a pedestrian crossing on the table top should be employed.
- Before implementing a single hump or a series of speed humps, their potential impact on the traffic flows in the local road network must be assessed. If there is a potential to shift traffic onto adjacent streets, an area wide approach to implementation should be adopted, to encourage appropriate operating levels on the road hierarchy.
- Speed humps are not suitable on class 1, 2 or 3 category roads, where mobility is the primary function, and they are only suitable under certain circumstances on class 4 category roads (where pedestrian/vehicle conflicts are high and/or accessibility is the primary function). They are recommended for use on residential access roads and in 'shared space' environments.
- A single speed hump is not suitable on roads carrying high volumes of traffic (peak hour volumes greater than 400 to 60 vph) or on roads where the majority of vehicles travel above a certain speed (85th percentile speed greater than 70 km/h).
- A typical size speed hump (designed for normal passenger cars) will impact severely on long heavy vehicles, such as buses, service vehicles and HGV's. They also have major implications for emergency vehicles, affecting mobility and riding comfort. They should therefore not be placed on routes frequently used by these types of vehicle. Speed humps also prove potentially dangerous for two wheeled vehicles, such as bicycles and motorcycles.
- An increase in noise and vibration levels will be experienced with the installation of speed humps. Possible adverse effects on air pollution are unknown. Speed humps are considered by some residents to be unsightly. Because of the intense wear to which they are exposed, the need for regular maintenance, and the associated costs, are further

negative implications.

- Careful attention must be given to ensuring that adequate drainage is provided. It is essential that the 'damming' effect in the vicinity of the hump is avoided, as a build up of water can have severe safety implications and could effectively 'hide' the speed hump, particularly at night.
- Speed humps must be easily visible to motorists and the recommended warning traffic signs and road markings must be provided. For road markings use of a high quality retro-reflective paint is recommended, as are road studs. The need for adequate lighting to ensure that the speed humps are sufficiently visible at night is also essential. Decision Sight Distance should also be considered when deciding on the positioning of humps.
- The success of a single hump or a series of speed humps depends on the acceptance of the plans by local residents and other affected parties. Where possible, residents should be involved in the planning phase. It is important to communicate to them the reasons behind decisions, to highlight both the potential benefits and negative impacts, and to discuss their specific concerns surrounding the planned implementation.
- During the construction phase careful inspection of the construction works should be carried out to ensure that the speed humps are accurately constructed to the correct dimensions and spacings. Particular attention must be paid to signing, marking and drainage. The traffic flow characteristics in the vicinity of the sight should be monitored to determine the success of the implementation, and where possible fine tuning should be investigated.
- The height of a speed hump is determined by the maximum desired speed at which normal passenger cars should comfortably negotiate the hump. The spacing between speed humps in a series is determined by the maximum desired speed vehicles should attain in between humps. To minimise acceleration and braking between humps, these two speeds should correspond.
- Semi-circular and trapezoidal speed humps are the most commonly used. Semi-circular (round top) speed humps are typically 3.7 metres long and between 80 and 120mm in height. Trapezoidal (flat top) speed humps typically vary between 100 and 120mm in height, and between 5 and 12.4 metres in length. The ramps vary between 1:15 and 1:40 and the top of the hump varies between 2 and 2.4 metres in length.

7. References

- 1 **National Guidelines for Traffic Calming**. 1996. Pretoria: Dept of Transport. (COD Report; CR-96/036).
- 2 HAVELL, D.F. 1993. **Traffic Management in Residential Streets**. Thesis; University of Witwatersrand, Johannesburg.
- 3 **Guidelines for the geometric design of urban arterial roads**. 1986. Pretoria: National Institute for Transport and Road Research, CSIR. (Urban transport guidelines; draft UTG1).
- 4 HASS-KLAU, C; Nold, I; BOCKER, G. and CRAMPTON, G. 1992. **Civilised Streets - A guide to traffic calming**. Brighton, UK; Environmental and Transport Planning.
- 5 **National Guidelines, Standards and Warrants for Traffic Calming Measures - a literature review**. 1994. Pretoria: Dept of Transport. (Interim Report; IR 7/94).
- 6 **Pedestrian Facility Guidelines: Manual to plan, design and maintain safe pedestrian facilities**. 1992. Pretoria: Dept of Transport. (Research Report; RR 92/126).
- 7 **South African Road Traffic Signs Manual**. 1993. Pretoria: Dept of Transport.
- 8 ZAIDEL, D; Hakkert, A.S; Pistiner, A.H. 1989. **A Critical Evaluation of the Use of Humps in urban Areas**. Israel: Transportation Research Institute. (Research Report; No. 89-139).

Appendix A: Road Class Classification

Appendix A: Road Class Classification

Class 1 : Trunk roads (National and regional distributors)

Generally these are rural roads whose function is to facilitate the regional distribution of traffic. They can be national or provincial roads and include freeways, expressways, dual carriageways and single carriageway main roads. Continuous sections of these roads in urban areas should be designed as by-pass routes. Route continuity is important.

Class 2 - Primary distributors or major arterials

These roads constitute the primary road network for the urban area as a whole. All long distance traffic movements to, from and within the city should be accommodated on these roads. They are characterised by high traffic volumes, limited access and fairly high speeds. Route continuity is again important.

Class 3 - District distributors or minor arterials

These roads form the link between the primary road network and roads within the residential and other land use areas. They distribute traffic between the various residential, commercial and industrial districts of the urban area. They should connect areas without passing through them. These roads are characterised by high traffic volumes, restricted access and moderate speeds. The major public transport movement is accommodated by these roads which therefore must also provide the necessary supporting infrastructure (preferably off the travelled roadway). Once again route continuity is important.

Class 4 - Local Distributors

These are local through routes which distribute traffic within communities and link district distributors and access roads. Local bus services can be accommodated on these roads and therefore they should be open ended. Local distributors should accommodate traffic generated by between 400 and 1200 dwelling units. The road layout should discourage extraneous traffic (i.e. there should be no available short-cuts between adjacent class 2 or 3 roads). Access to individual properties should not be encouraged.

These roads should not be continuous between adjacent neighbourhood cells (e.g. through the provision of staggered intersections etc.)

Class 5 - Residential access roads

These roads provide direct access to property within the residential area. Access for motor vehicles is not their only function and the roads are also used by inhabitants for recreational purposes (running, cycling, walking, etc.). They also accommodate the provision and maintenance of services and stormwater management.

These roads are minor roads serving a maximum of 200 dwelling units. They do not require continuous alignments and form part of a closed network. In descending order of priority, the hierarchy of these roads is as follows:

Class 5a (residential access collector) :

These provide a link between the local distributor and any other access roads. They service up to 200 dwelling units and should not provide short cuts for any traffic using the local or district road network. They may be part of an open system or a closed system with one outlet onto the local distributor (i.e. functions as an access way). Access to properties is allowed where sight distances are not a problem.

Class 5b (Access loop) :

These carry traffic from about 120 dwelling units, providing a short link for cul-de-sacs, access courts and private roads to a residential access collector. They should not be linked with local distributors. Separate paved footways may be justified in high density, low income areas with high pedestrian volumes. These roads should be designed for joint use by pedestrians and vehicles.

Class 5c (Access cul-de-sac) :

These are small informal roads providing direct frontage access to between 6 and 60 dwelling units. They should generally not exceed 150 m in length. They are ideally suited to low to medium density (< 500 m²) developments with open plan front gardens and where parking is provided on the property. Again these roads should be for joint use by pedestrians and vehicles. To emphasise joint use contrasting design features (e.g. block paving) can be incorporated. Vehicle speeds should be restricted to 20 km/h.

Class 5d (Access way) :

These are closed road systems with an exit on only one end. It may have variable width (3 to 5 m) and typically carrying traffic generated by up to 60 dwelling units. They may link access courts to each other and/or to other class 5 roads. These roads are not intended to provide direct access to single buildings (this is not advised where road width is less than 4,5 m). The design should ensure consistent low speed and be clearly marked at its entry to demarcate its' special character.

Class 5e (Access court) :

These give access to about 30 dwelling units with contrasting design to indicate shared use. The design should ensure low speed, especially since these roads may be used by children for playing. Access courts are particularly suited to be used in conjunction with access ways at developments where the net density exceeds 16 dwellings/hectare. Access courts may provide links between adjacent access ways to accommodate emergency and service vehicles. However, general use should be discouraged.

Class 5f (Access strip):

These are also known as double panhandles and provide access to a maximum of 4 dwelling units. No turning circle is provided and the roads can be either public or private. Parking must be provided on each property.

Private roads:

These are not the property of the authorities and the road reserves are determined by the owners of such property. However, these roads should be designed to be consistent with public roads of similar function.

Appendix B: Traffic Signs and Road Markings for Speed Humps

Appendix B: Traffic Signs and Road Markings for Speed Humps

12.4.5 Notes on Figure 12.7

(1) Signs and Markings per Approach

Quantity	Type	Min. External Dimension (mm)
1	W401	600x150
1	W402	600x150
1	W332	900 side
1	IN 11.1	900 wide
1	IN 11.3	900 wide
1	RM1	
1	RM4.1	
PLUS per speed hump		
1	WM10	200 stripes
3	Red roadstuds	
4	Yellow roadstuds	

* = optional signs

(2) When several speed humps comprise an area traffic calming treatment the use of high visibility signs W332-WB-IN11.1 at the main entry points to the area is recommended. The normal size of such signs is 1600mm x 1200mm but 1200mm x 900mm may be specified. If a reduced speed limit is imposed within such an area the use of high visibility "Zone Ends" R201-WB signs may be warranted on leaving the area.

(3) If the area is subject to a variety of traffic calming measures sign W201-WB-IN11.2 may be replaced by one of signs W332-WB-IN11.2 or W332-WB-IN11.1 as appropriate (see Figure 12.2).

(4) Checklist

The following factors should be checked when considering signing for traffic calming measures which include speed humps:

- does street lighting exist in the area?
- is the speed hump an isolated one or part of an area traffic calming treatment?
- is the speed hump part of a traffic calming treatment involving a range of different traffic calming measures?
- is the speed hump a flat top hump which is used as a pedestrian crossing?

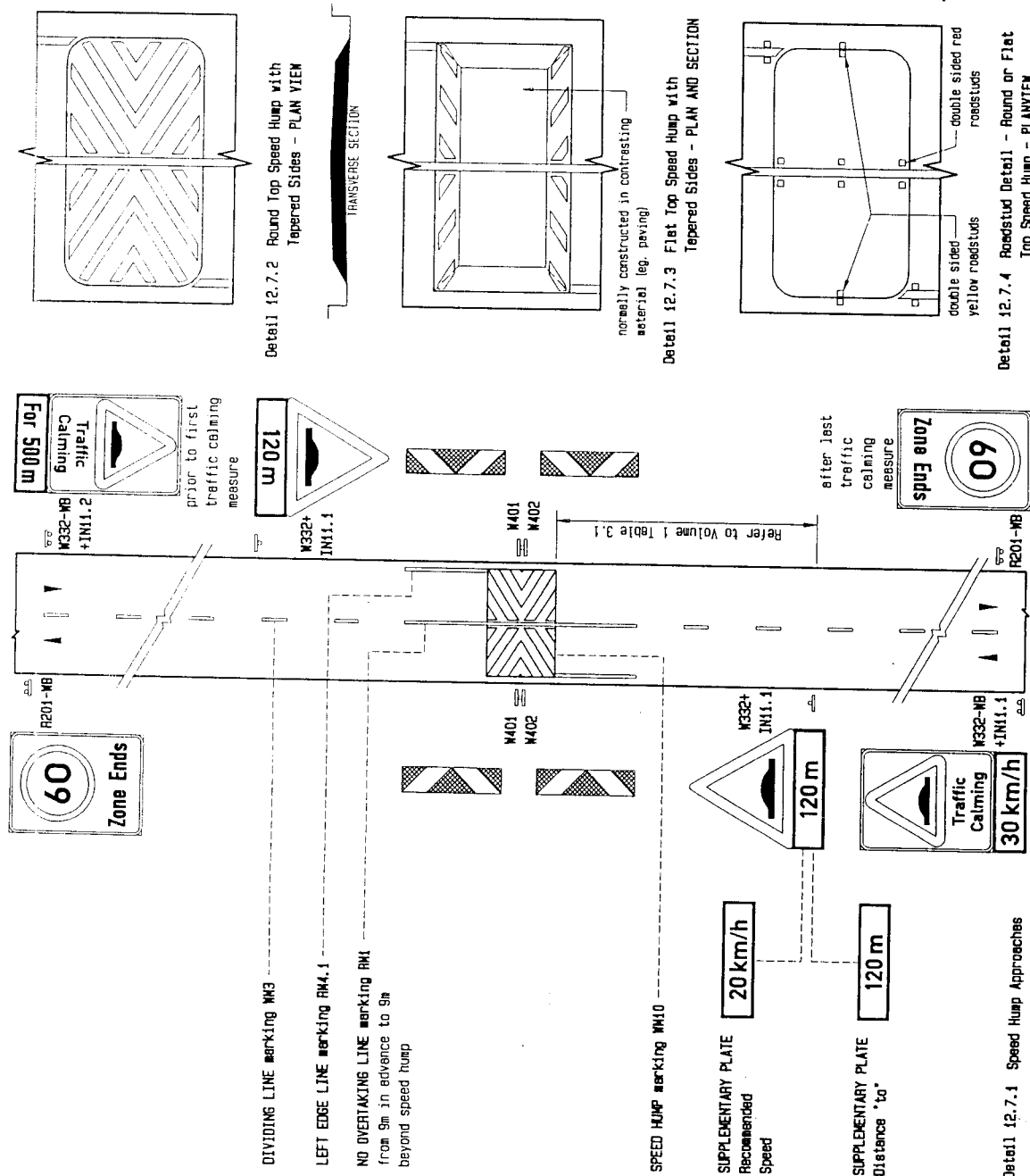

Fig. 12.7 Typical Road Sign Layout For Speed Humps

SYMBOLIC

3.4.27

SPEED HUMPS
SPOEDHOBBELS

COLOURS/KLEURE:

PERMANENT

Triangle: Red retroreflective
 Symbol: Black semi-matt
 Background: White retroreflective

TEMPORARY

Triangle: Red retroreflective
 Symbol: Black semi-matt
 Background: Yellow retroreflective

PERMANENTE

Driehoek: Rooi truikaatsend
 Simbool: Swart halfdot
 Agtergrond: Wit truikaatsend

TYDELIKE

Driehoek: Rooi truikaatsend
 Simbool: Swart halfdot
 Agtergrond: Geel truikaatsend

W332



For dimensions/
 vir afmetings
 ref. I/verw. Vol. 4
 page/bladsy
 3.4.32

TW332



3.4.26 Speed Humps

- 1 The SPEED HUMPS warning sign W332 is *to warn road users of speed humps on the roadway ahead* which require a reduction in speed.
- 2 Sign W332 should be displayed when correctly designed speed control humps have been installed to reduce traffic speed in residential, parking or roadworks environments. The UNEVEN ROADWAY warning sign W331 should not be used to warn traffic of speed humps.
- 3 The sign should be located in advance of the hazard at a distance dependent on the operating speed or, in the case of a speed hump immediately after a turn, the average speed at which the hazard can be negotiated safely. If a number of speed humps are installed the sign should preferably be located within 30m ahead of the first hump which should be placed within 50m of the start of a section of roadway so that drivers encounter the hump at low speed. The sign should preferably be displayed with a supplementary distance information plate, indicating the length of section of roadway over which the speed humps exist. If the operating speed is relatively high it is recommended that the speed humps be preceded by a W332 warning sign located in accordance with Table 3.1 or Figure 3.1 and supplemented by a distance plate giving the distance (rounded) to the first speed hump. These plates should be mounted on the same post below the W332 sign.
- 4 Temporary warning sign TW332 may be used under the same circumstances as permanent SPEED HUMPS warning signs when speed humps are used to reduce speeds at roadworks sites.

3.4.26 Spoedhobbels

- 1 Die SPOEDHOBBELS-waarskuwingstekens W332 is daar *om padgebruikers te waarsku dat daar spoedhobbels op die padbaan vorentoe is*, wat 'n vermindering van spoed vereis.
- 2 Die W332-teken behoort vertoon te word as korrek ontwerpte spoedhobbels aangebring is om verkeerspoed in woon-, parkeer- of padwerkomgewings te verminder. Die HOBBELPAD-waarskuwingstekens W331 behoort nie gebruik te word om verkeer teen spoedhobbels te waarsku nie.
- 3 Die teken behoort voor die gevaarpunt geplaas te word op 'n afstand wat afhang van die bedryfspoed of, waar 'n spoedhobbel onmiddellik na 'n draai voorkom, die gemiddelde spoed waarmee die gevaarlike gedeelte veilig oorgegaan kan word. Indien daar 'n aantal spoedhobbels aangebring word, behoort die teken verkieslik binne 30m voor die eerste hobbel geplaas te word, en die hobbel binne 50m vanaf die begin van 'n padbaangedeelte geplaas te word sodat bestuurders die hobbel teen 'n lae spoed tæekom. Die teken behoort verkieslik vertoon te word tesame met 'n aanvullende afstandinligtingsplaat wat die lengte van die padbaangedeelte waarop die spoedhobbels voorkom, aandui. Indien die bedryfspoed redelik hoog is, word aanbeveel dat die spoedhobbels voorafgegaan word deur 'n W332-waarskuwingstekens wat in ooreenstemming met Tabel 3.1 of Figuur 3.1 geplaas is, en aangevul word deur 'n afstandplaat wat die afstand (benaderd) na die eerste spoedhobbel aandui. Hierdie plaat behoort aan dieselfde paal onder die W332-teken bevestig te word.
- 4 Die tydelike TW332-waarskuwingstekens mag in dieselfde omstandighede as die permanente SPOEDHOBBEL-waarskuwingstekens gebruik word as spoedhobbels gebruik word om spoed by padwerkerreine te verminder.

SPEED HUMP SPOEDHOBBEL

COLOUR/KLEUR:

White
Wit

For dimensions/
vir afmetings
ref./verw. Vol. 4

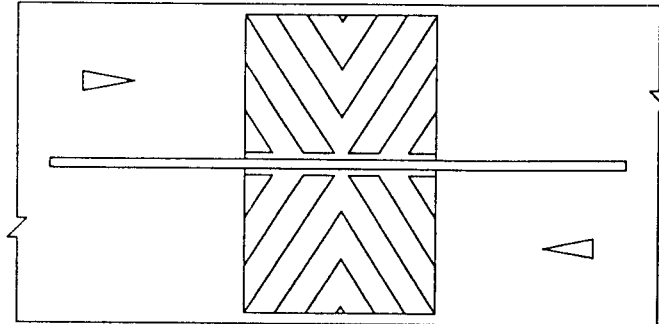

WM10

7.3.10 Speed Hump

- 1 A SPEED HUMP warning marking WM10 is *to warn road users of a speed hump in the roadway.*
- 2 A SPEED HUMP marking shall comprise diagonal white lines with a minimum width of 200mm. The marking shall be applied to the approach side of the speed hump. Its use on the reverse side of the speed hump is optional.
- 3 It is recommended that when speed humps are used a NO OVERTAKING LINE marking RM1 be marked from 9m in advance to 9m beyond the speed hump.
- 4 If speed humps are used in areas which are environmentally sensitive in that special roadway finishes have been used the SPEED HUMP marking need not be used. It is recommended that a similar pattern of diagonal lines be incorporated into the roadway surface finish if possible.

7.3.10 Spoedhobbel

- 1 'n SPOEDHOBBEL-waarskuwingsmerk WM10 is daar *om padgebruikers te waarsku dat daar 'n spoedhobbel in die padbaan is.*
- 2 'n SPOEDHOBBEL-merk moet uit wit skuinsstreepe met 'n minimum breedte van 200mm bestaan. Die merk moet aan die naderingskant van die spoedhobbel aangebring word. Die gebruik daarvan op die agterkant van die spoedhobbel is opsioneel.
- 3 Daar word aanbeveel dat 'n VERBYSTEEKVERBOD-STREEP RM1 vanaf 9m voor tot 9m na die spoedhobbel gemerk word as spoedhobbels gebruik word.
- 4 Indien spoedhobbels in sensitiewe omgewings gebruik word waar spesiale padbaanafwerkings gebruik is, hoef die SPOEDHOBBEL-merk nie gebruik te word nie. Daar word aanbeveel dat 'n soortgelyke skuinsstreeppatroon in die padbaanoppervlakaferwing ingelaat moet word indien dit moontlik is.

HAZARD MARKER

3.5.1

DANGER PLATES/DELINATOR PLATES
GEVAARPLATE/DELINIEERPLATE

COLOURS/KLEUR:

PERMANENT
Red retroreflective
on white retroreflective

TEMPORARY
Black semi-matt
on yellow retroreflective

PERMANENT
Rooi truakaatsend
op wit truakaatsend

TYDELIKE
Swart halfdot
op geel truakaatsend



W402



W401

For dimensions/
vir afmetings
ref./verwys. Vol.
4
page/bladsy
3.5.1



TW402



TW401

3.5.1 Danger Plates/Delineator Plates

- 1 The DANGER PLATE warning signs W401 and W402 and the DELINEATOR PLATE temporary warning signs TW401 and TW402 are to warn road users of an obstruction or temporary obstruction, in the roadway, or alteration or temporary alteration, in the roadway alignment to the right or left side of the roadway.
- 2 Signs W401 and W402 should be displayed at all hazardous obstructions that occur within the shoulder or verge of a roadway such as bridge abutments, culvert head-walls or posts without guardrail protection. Sign W401 should be used on the left side of the roadway so that traffic passes to the right of the plate. Sign W402 should be used on the right side of the roadway so that traffic passes to the left of the plate.
- 3 Open ditches, high embankments and ill-defined curves, particularly where roadside space is limited in urban areas may be demarcated using a number of DANGER PLATE hazard markers. (See Subsection 3.5.3 on page 3.5.4.)
- 4 Sign W401 or W402 shall be mounted horizontally with the arrow pointing downwards on an overhead structure on each side of HEIGHT LIMIT sign R204 when such sign is used to regulate the use by traffic of a structure which has limited vertical clearance. (See Subsection 2.4.4.)
- 5 Signs TW401 and TW402 should be displayed at all obstructions at roadworks sites which are potentially hazardous. Sign TW401 should be used on the left side of the roadway so that traffic passes to the right of the plate. Sign TW402 should be used on the right side of the roadway so that traffic passes to the left of the plate. In addition delineator plates should be used to indicate temporary road alignments which occur at roadworks sites. 200 litre, or similar drums shall not be used for this purpose.
- 6 DANGER PLATES and DELINEATOR PLATES should have a minimum size of 600mm height and 150mm width. The ratio of height to width should be maintained at 4 to 1 up to a maximum size of 1 200mm x 300mm, which size should be used to indicate bridge

3.5.1 Gevaarplate/Delinieerplate

- 1 Die GEVAARPLAAT-waarskuwingstekens W401 en W402 en die tydelike DELINIEERPLAAT-waarskuwingstekens TW401 en TW402 is daar om padgebruikers te waarsku van 'n versperring of tydelike versperring in die padbaan, of om hulle te waarsku van 'n verandering of 'n tydelike verandering in die padbaan belyning aan die regterkant of linkerkant van dié padbaan.
- 2 Die W401- en W402-teken behoort vertoon te word by alle gevaarlike versperrings soos brughoofde, duikerkopmure of pale sonder skramrelings wat binne 'n padbaanskouer of -soom val. Die W401-teken behoort aan die linkerkant van die padbaan gebruik te word sodat verkeer regs van die plaat verbybeweeg. Die W402-teken behoort aan die regterkant van die padbaan gebruik te word sodat verkeer links van die plaat verbybeweeg.
- 3 Oop skote, hoë opvullings en onduidelik gemerkte draaie, veral waar die padkantruimte in stedelike gebiede beperk is, mag afgebaken word deur die gebruik van 'n aantal GEVAARPLAAT-gevaarmerkers. (Sien Onderafdeling 3.5.3 op bladsy 3.5.4.)
- 4 Die W401- of W402-teken moet horisontaal aan weerskante van 'n HOOGTEPERK-teken R204 aan 'n oorhoofse struktuur bevestig word sodat die pyl na onder wys, waar so 'n teken gebruik word om verkeer by 'n struktuur met vertikaal beperkte vry hoogte te reël. (Sien Onderafdeling 2.4.4.)
- 5 Die TW401- en TW402-teken behoort op padwerkerreine, by alle versperrings wat potensiële gevare is, vertoon te word. Die TW401-teken behoort aan die linkerkant van die padbaan gebruik te word sodat verkeer regs van die plaat verbybeweeg. Die TW402-teken behoort aan die regterkant van die padbaan gebruik te word sodat verkeer links van die plaat verbybeweeg. Delinieerplate behoort ook nog gebruik te word om tydelike padbelynings wat op padwerkerreine voorkom, aan te dui. 200-liter-, of soortgelyke dromme moet nie vir hierdie doel gebruik word nie.
- 6 GEVAARPLATE en DELINIEERPLATE behoort 'n minimum grootte van 600mm hoog en 150mm breed te hê. Die verhouding van hoogte tot breedte behoort 4 tot 1 te bly, tot 'n maksimum grootte van 1 200mm x 300mm, en hierdie grootte behoort gebruik te word om

BLOCK PEDESTRIAN CROSSING MARKINGS BLOK-VOETOORGANGMERKE

COLOUR/KLEUR:

White/Wit

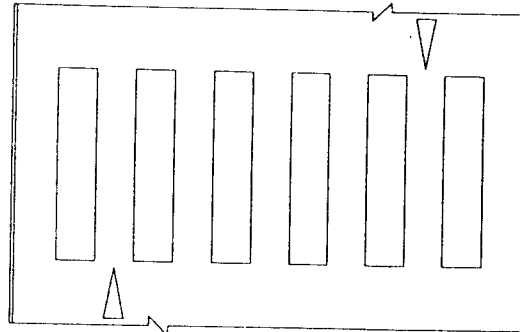

For dimensions/
vir afmetings
ref. verw. Vol. 4

RTM4

7.2.4 Block Pedestrian Crossing Markings

- 1 A BLOCK PEDESTRIAN CROSSING regulatory marking RTM4 imposes a mandatory requirement that drivers of vehicles *shall yield right-of-way, by slowing down or stopping if need be to so yield, to a pedestrian who is crossing the roadway or a portion of roadway, or to a pedestrian waiting to cross the roadway*, AND regulatory marking RTM4 imposes a mandatory requirement that pedestrians *shall only cross the roadway within the crossing defined by the markings and the edges of the roadway and/or median or other traffic island (if such are provided)*.

PROVIDED that :

- (a) if such BLOCK PEDESTRIAN CROSSING marking RTM4 is used in conjunction with a road sign or traffic signal, or STOP LINE marking RTM1 or YIELD LINE marking RTM2 *the significance of these road traffic signs shall take precedence;*
 - (b) pedestrians are crossing the roadway or portion of roadway in accordance with the prescribed indications of a traffic signal when such is provided.
- The actions of road users at pedestrian crossings are covered under Section 109 of the Road Traffic Act, Act 29 of 1989. The term *pedestrian crossing* has a legal significance and the requirements of the Act in this respect take precedence.
- 2 BLOCK PEDESTRIAN CROSSING markings shall comprise a number of rectangular white painted markings of minimum length 2,4m and minimum width 600mm, spaced 600mm apart which shall extend across the full width of the roadway or portion of roadway. A length of marking of 3m is preferred, and this dimension may be further increased if large volumes of pedestrians are present, to enable reasonable compliance with the provisions of paragraph 7.2.4.1. The necessary width may be determined by making the length of marking equal to 0,6m for every 125 pedestrians/hour based on the four peak hours. A maximum length of 5m is recommended.
 - 3 BLOCK PEDESTRIAN CROSSING marking RTM4 shall be preceded by a STOP LINE marking RTM1 if used at a traffic signal controlled crossing, or a YIELD LINE marking RTM2 when used at a road sign control-

7.2.4 Blok-voetorgangmerke

- 1 'n BLOK-VOETOORGANG-reëlingsmerk RTM4 stel 'n verpligte vereiste aan bestuurders van voertuie *om, deur stadiger te ry of stil te hou as dit nodig is, reg van voorrang moet toegee aan 'n voetganger wat besig is om die padbaan of padbaangedeelte oor te steek, of aan 'n voetganger wat wag om die padbaan oor te steek*, EN die RTM4-reëlingsmerk stel 'n verpligte vereiste aan voetgangers *om die padbaan slegs binne die oorgang wat deur die padmerke en padbaankante, en/of die mediaan- of ander verkeerseiland (indien dit voorsien is) gedefinieer is, moet oorsteek*.

MET DIEN VERSTANDE dat :

- (a) indien so 'n BLOK-VOETOORGANG-merk RTM4 saam met 'n padteken of verkeersein, of STOPSTREEP-merk RTM1, of TOEGEESTREEP-merk RTM2 gebruik word, *hierdie padverkeerstekens se betekenis eerste moet geld;*
 - (b) voetgangers die padbaan of padbaangedeelte oorsteek in ooreenstemming met die voorgeskrewe verkeerseinaanduidings as verkeerseine voorsien is.
- Die aksies van padgebruikers by voetorgange word gedek deur afdeling 109 van die Padverkeerswet, Wet 29 van 1989. Die term voetorgang het 'n wettige betekenis en die vereistes van die Wet in hierdie opsig geniet voorkeur.
- 2 BLOK-VOETOORGANG-merke moet oor die volle breedte van die padbaan of padbaangedeelte strek en uit 'n aantal reghoekige wit geverfde merke met 'n minimum lengte van 2,4m en 'n minimum breedte van 600mm, met 'n spasie van 600mm tussenin, bestaan. 'n Merklengte van 3m word verkies, en hierdie afmeting mag verder vergroot word as groot voetgangervolumes teenwoordig is sodat die bepalinge van paragraaf 7.2.4.1 in redelike mate nagekom kan word. Die nodige breedte mag bepaal word deur die merklengte te neem as 0,6m vir elke 125 voetgangers/uur, gebaseer op die vier spitsure. 'n Maksimum lengte van 5m word aanbeveel.
 - 3 BLOK-VOETOORGANG-merk RTM4 moet voorafgegaan word deur 'n STOPSTREEP-merk RTM1, as dit by 'n verkeerseinbeheerde oorgang gebruik word, of 'n TOEGEESTREEP-merk RTM2, as dit by 'n padteken-

3.4.6

SIMBOLIESE

PEDESTRIAN CROSSING
VOETOORGANG

For dimensions/
vir almetings
ref: verw. Vol. 4
page/bladsy
3.4.6

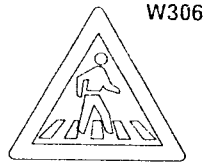

W306

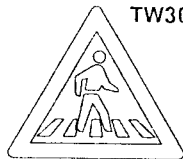

TW306

COLOURS/KLEUR:

PERMANENT

Triangle: Red retroreflective

Symbol: Black semi-matt

Background: White retroreflective

TEMPORARY

Triangle: Red retroreflective

Symbol: Black semi-matt

Background: Yellow retroreflective

PERMANENTE

Dreieek: Rooi truakaatsend

Simbool: Swart halfdot

Agiërgrond: Wit truakaatsend

TYDELIKE

Dreieek: Rooi truakaatsend

Simbool: Swart halfdot

Agiërgrond: Geel truakaatsend

3.4.6 Pedestrian Crossing

- 1 The PEDESTRIAN CROSSING warning sign W306 is to warn road users of a marked pedestrian crossing ahead.
- 2 Sign W306 should, where possible, be displayed not less than 90m or more than 180m in advance of any block-marked pedestrian crossing. In addition, if the block-marked crossing is primarily for school children a CHILDREN warning sign W308, should be placed a suitable distance in advance of sign W306. A pedestrian crossing controlled by a traffic signal should be preceded by a TRAFFIC SIGNALS AHEAD warning sign W301, as detailed in Subsection 3.4.1
- 3 A temporary warning sign TW306 should be used if a temporary pedestrian crossing is installed as part of a roadworks detour.

3.4.6 Voetoorgang

- 1 Die VOETOORGANG-waarskuwingstekens W306 is daar om padgebruikers te waarsku dat daar 'n gemerkte voetoorgang vorentoe is.
- 2 Die W306-teken behoort, sover moontlik, nie nader nie as 90m, of nie verder nie as 180m, voor enige blokgemerkte voetoorgang vertoon te word. Verder behoort 'n KINDERS-waarskuwingstekens W308, op 'n geskikte afstand voor die W306-teken geplaas te word as die blokgemerkte voetoorgang hoofsaaklik vir skoolkinders bedoel is. 'n Voetoorgang wat deur 'n verkeersein beheer word, behoort voorafgegaan te word deur 'n VERKEERSEINE VOOR-waarskuwingstekens W301, soos gedetailleerd in Onderafdeling 3.4.1.
- 3 'n Tydelike TW306-waarskuwingstekens behoort gebruik te word indien 'n tydelike voetoorgang in werking gestel word as deel van 'n padwerkverlegging.