

Development of a Sine-Dwell Ground Vibration Test (GVT) System

Presented at CSIR Research and Innovation Conference: 27 - 28 February 2006

DPSS

Mr Louw van Zyl

Mr Erik Wegman

27 February 2006



Agenda

- **Introduction**
Why ground vibration testing?
- **Basics of sine-dwell testing**
Getting the structure to vibrate in phase, and what then?
- **Excitation hardware**
Exciters are similar to speakers
- **Measurement system**
Force and response as complex numbers
- **Excitation control**
Applying the required force
- **Hardware implementation**
Data acquisition processor card or CAN-bus
- **Future developments**
Quadratic mode shapes, laser vibrometry

Introduction

- Why do Ground vibration tests?

Knowledge of the natural modes of vibration of a structure is required to solve or avoid vibration and flexibility problems in industrial, automotive, aerospace and civil engineering applications. All new aircraft must undergo a flutter clearance to ensure that it will be free from flutter within the intended operating envelope. Long-span bridges are also subject to flutter, and high-rise buildings can oscillate severely in high winds. Vibrations in industrial installations are also quite common and are often due to the unfortunate matching of an excitation frequency and a natural frequency of the installation. The methods of determining the natural modes of a structure are continually evolving, and this paper describes one GVT system with some novel features.

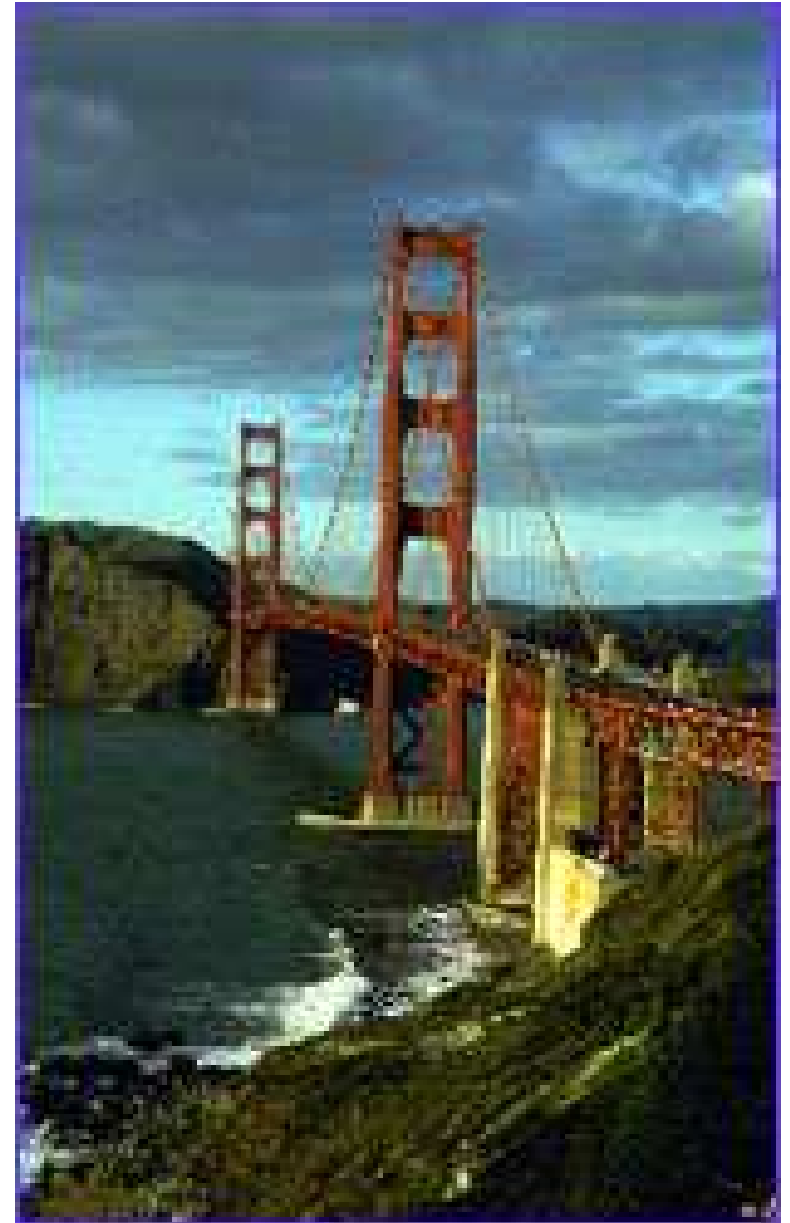

Basics of sine-dwell testing

- The essence of sine-dwell vibration testing is:
 - get the structure to vibrate in phase (modal isolation)
 - extract the modal parameters by recording the complex power over a small frequency range centered on the resonant frequency
 - extract the modeshape by recording the vibration amplitudes at the resonant condition

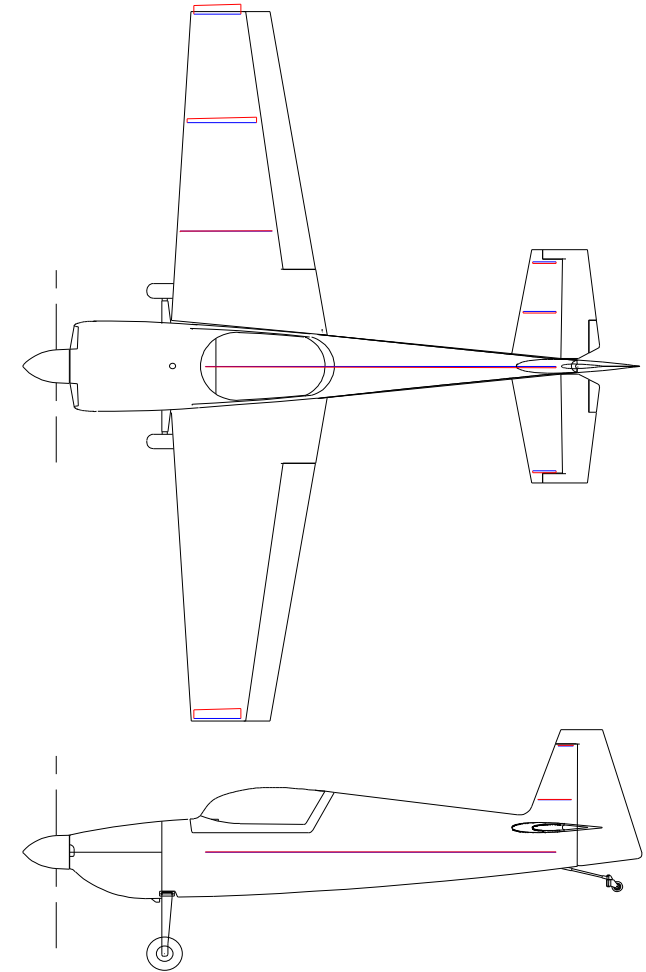
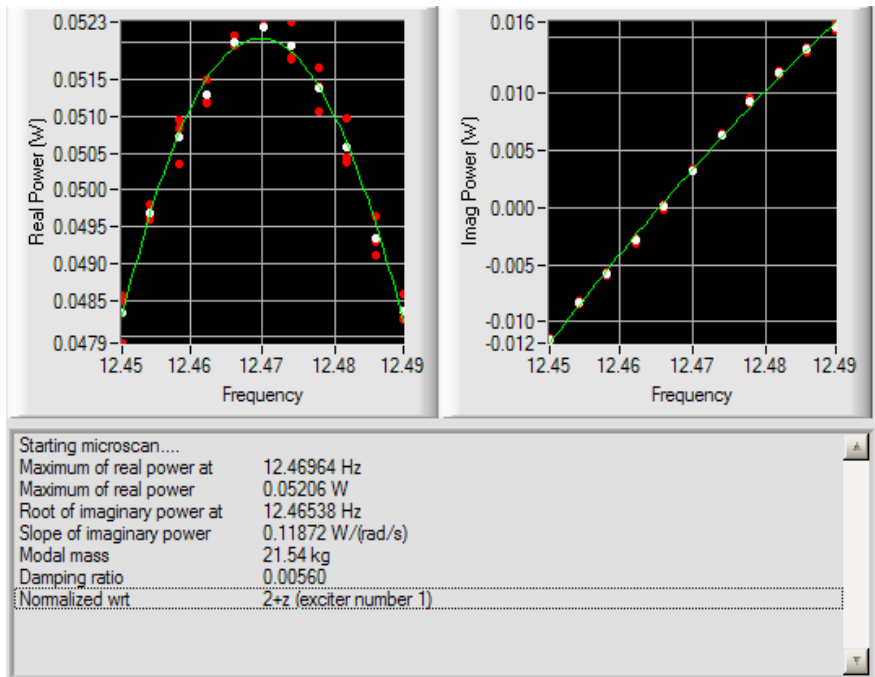

Excitation hardware

- Exciters are similar to speakers
 - The electromechanical exciters that are typically used for GVTs consist of a light coil moving in a magnetic field. The coil is attached to the structure by means of a “stinger”, a piece of stiff wire. A current passing through the coil results in a force on the coil, which is transmitted to the structure through the stinger. The reaction force on the exciter body, which is essentially a permanent magnet, is absorbed either by the exciter support or by the mass of the exciter.

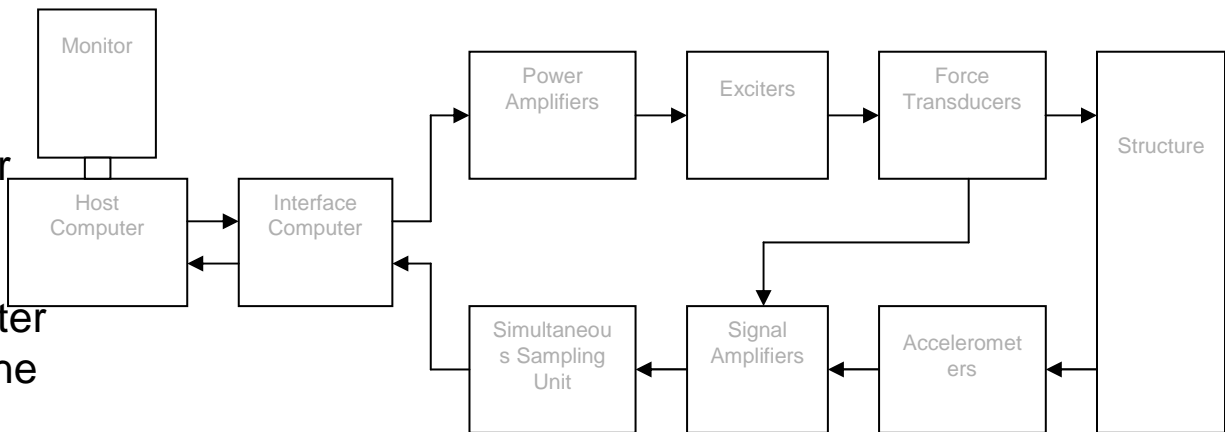

Excitation hardware

- Useful properties of exciters
 - Movement of the coil through the magnetic field generates a back emf. The current flowing through the coil is determined by the back emf, the voltage supplied to the exciter and the coil impedance. The exciters are driven by amplifiers which can be used in either current mode or voltage mode. In the former mode the amplifier will supply the necessary voltage to ensure that the current flowing through the exciter coil is proportional to the input signal to the amplifier. In voltage mode the amplifier will supply a voltage to the exciter that is proportional to the input signal, with no regard for the actual current that flows through the exciter coil.
 - In the present system the amplifiers are always used in voltage feedback mode. This implies that the amplifier and electro-mechanical exciter combination can be regarded as a viscous damper attached at one end to the structure and driven at the other end with a prescribed motion. The structure is thus attached to powerful dampers, which reduces structural settling time without any effect on the results. This model also allows for a simple, additive, excitation control algorithm to be used. Such an algorithm is necessary to ensure that the force that is transferred to the structure equals the force specified by the operator.

Measurement system

- Force and response as complex numbers
 - The system is designed to accept a mixture of sensors. The transfer function of each sensor is supplied in a transducer definition file. The basic response quantity is velocity and all transfer functions (except for force measurement) relates voltage to velocity. This has several advantages: At resonance the force and velocity at the excitation points is in phase, the formulas for the complex power method is easy to derive and code, and the output voltage to the amplifiers can be regarded as a velocity command.
 - The input signals from all the force and response sensors are converted to real and imaginary voltages with an arbitrary but common phase reference. The transfer functions are then applied to obtain the real and imaginary parts of the applied forces and velocity at the measurement points. Finally, these values are related to a common phase reference derived from the controlled excitation parameters.
 - Determining the real and imaginary parts of each signal is done by sampling over a number of cycles and determining the first cosine and sine Fourier coefficients of the signal by means of numerical integration. These coefficients are directly related to the real and imaginary parts in the complex description of the signal. In addition, low frequency components, typically from rocking on the air supports in the case of aircraft, are eliminated by assuming that they will appear as parabolic functions in the sampling window. The numerical integration, including the elimination of low frequency components, is expressed as a matrix product of a $2 \times n$ matrix with the vector of n sampling points. The resulting vector with length 2 contains the real and imaginary parts of the signal. The $2 \times n$ matrix is calculated each time that the excitation frequency is changed.

Excitation control

- Applying the required force
 - The excitation control algorithm is a critical part of a sine-dwell GVT system. Its purpose is to ensure that the applied forces exactly match the forces specified by the operator. The scheme that is implemented in the present system is an additive scheme. Two transfer functions of the amplifier and exciter combinations are read from the transducer definition file: the transfer function from input voltage to output force for a restrained exciter, and the transfer function from input voltage to output velocity for a free exciter. In force control mode, the difference between the specified force and the actual force is divided by the former transfer function and the result is added to the output voltage. In velocity control mode, the difference between the specified velocity and the actual velocity is divided by the latter transfer function and the result added to the output voltage. This scheme can be shown to be unconditionally stable for a single exciter system, and experience has shown that it is also stable for multiple exciters. The force control algorithm converges quickly in the case of massive structures, but very slowly for light, lowly damped structures. The velocity control algorithm converges rapidly for light and lowly damped structures, therefore at least one of the modes should be able to isolate any particular mode.

Hardware implementation

- Data acquisition processor card or CAN-bus
 - The original implementation of the present system employed a data acquisition processor (DAP) card for data acquisition and processing of each signal to real and imaginary parts. This implementation required all signals to be physically routed to a central processing unit, resulting in a rather untidy web of cables. The CAN (controller area network) bus was developed by Bosch to reduce the amount of wiring in modern cars. In the GVT application each CAN node is connected to and does the data acquisition and processing for 8 accelerometers. The results are then sent to the host PC over the bus, which is physically a single cable connecting all the CAN nodes in series.

Future developments

- **Parabolic mode shapes**

Recent theoretical investigation into the prediction of T-tail flutter using the subsonic DLM as sole source of aerodynamic loads indicated that it is necessary to use a second-order description of the modeshape, i.e. of the form

$$\underline{x} = q\underline{h}_1 + q^2 \underline{h}_2$$

where \underline{x} is the modal displacement vector and q is the generalized coordinate. \underline{h}_1 is the linear or first-order component of the modeshape that is normally determined by a GVT or a linear dynamic FE analysis. Extracting \underline{h}_2 is a straightforward extension of the present sine-dwell method .

- **Laser vibrometry**

The present system was developed around a combination of high quality impedance heads (combined force transducer and accelerometer) at the excitation points and low-cost accelerometers at the other measurement positions. Laser measurement systems already exist that could replace the low-cost accelerometers completely. One drawback of the laser system is that transfer functions need to be measured sequentially whereas modern technology allows for the simultaneous recording of several hundred transfer functions when using accelerometers