

# FATIGUE PROPERTIES OF ADDITIVELY MANUFACTURED TOOL STEEL ICAS PAPER 2024\_0633

C.M. Johnston, L.C. Tshabalala, and M. Davids  
Council for Scientific and Industrial Research (CSIR)



Introduction  
Approach  
Process  
Results  
Summary  
Further work



# INTRODUCTION

---

- The Aerospace group of the CSIR started using polymer **Rapid Prototyping** in the mid-1990's.
- In 2006 the first **3D printed** part was tested in the transonic Medium Speed Wind Tunnel (MSWT).
  - Alumide
  - Not load bearing
- As metal **AM** machines became available in South Africa, more grown parts were used in wind tunnel models and instrumentation.
- To extend the use of AM to highly stressed components, the **fatigue characteristics** of the materials are required.
  - Tool steel
  - 17-4PH Stainless steel



# APPROACH

- Plan tests
  - Identification of relevant fatigue test
  - Choice of fatigue test specimen geometry
- Manufacture
  - Grow 30 specimens
  - Thread specimens to fit Universal Testing Machine
  - Heat treat some specimens
  - Surface finish test area
- Test
  - Tensile tests
  - Fatigue tests

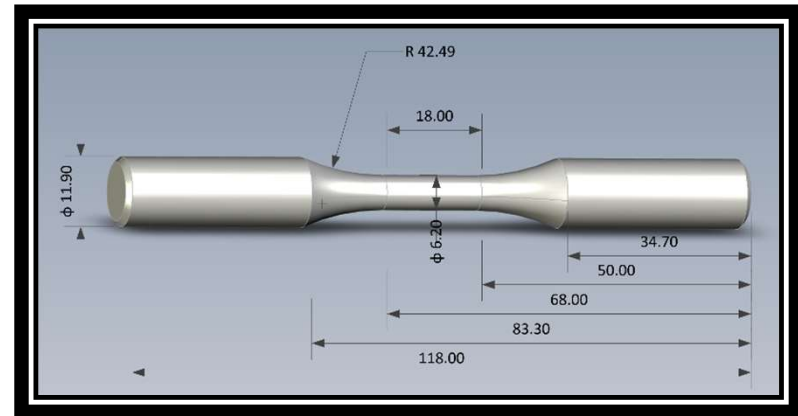

# APPROACH

- Plan tests
  - Identification of relevant fatigue test.
  - Choice of fatigue test specimen geometry.
- Manufacture
  - Grow 30 specimens.
  - Thread specimens to fit Universal Testing Machine.
  - Heat treat some specimens.
  - Surface finish test area.
- Test
  - Fatigue tests
  - Tensile tests

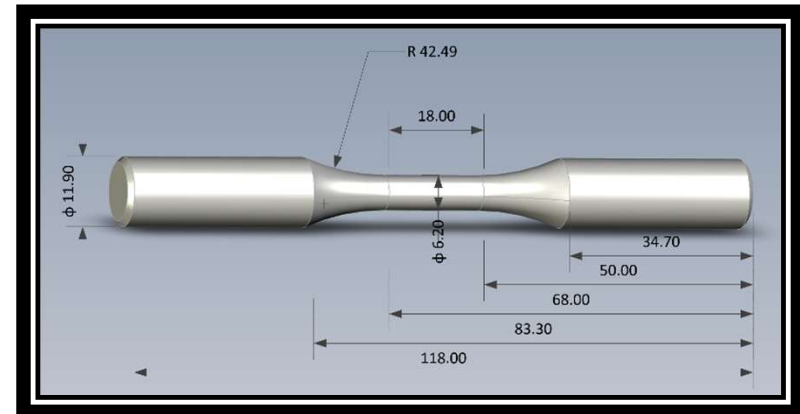

# PROCESS ... MANUFACTURING

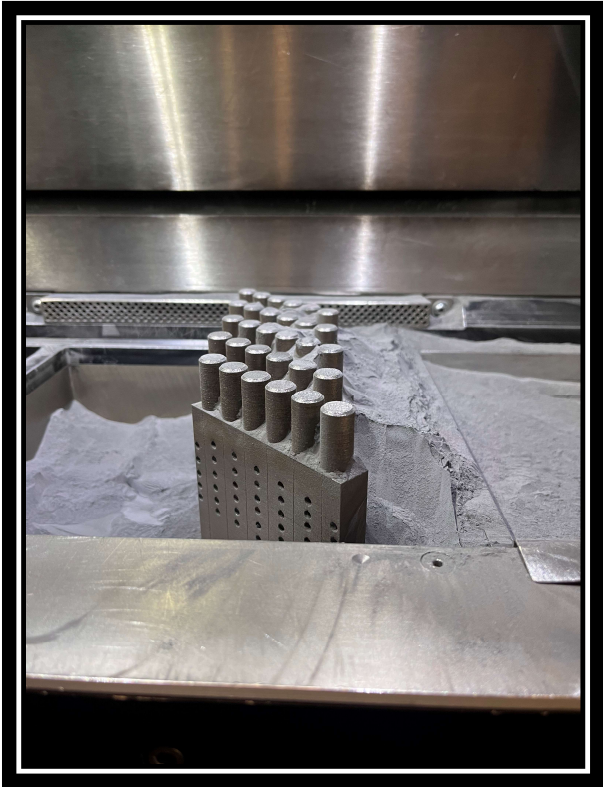

## PROCESS ... CT SCANS

---

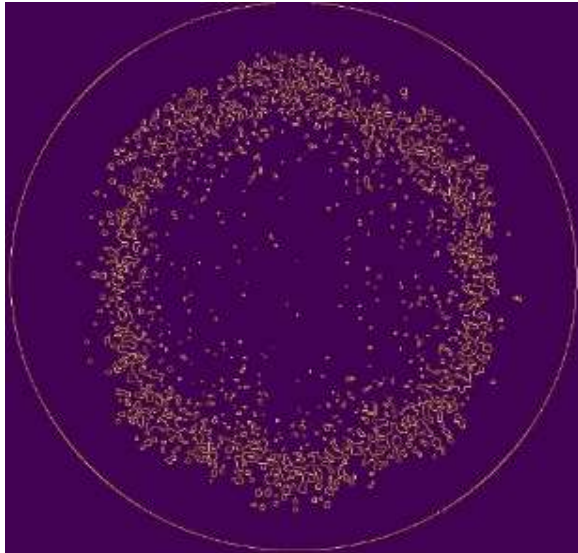

Before ageing

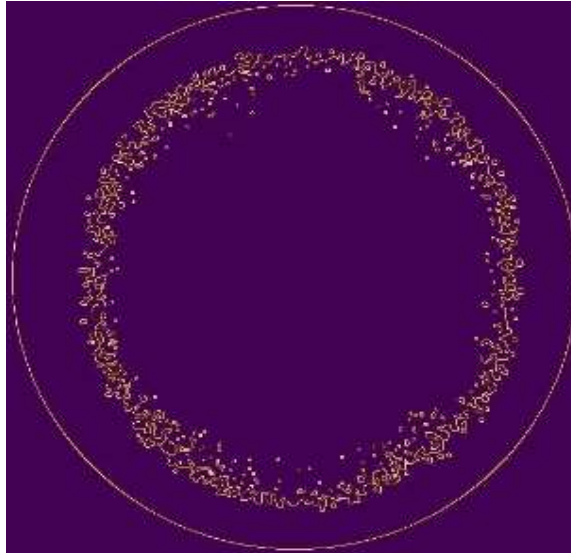

After ageing

- Each specimen scanned before and after aging

# PROCESS ... TESTING

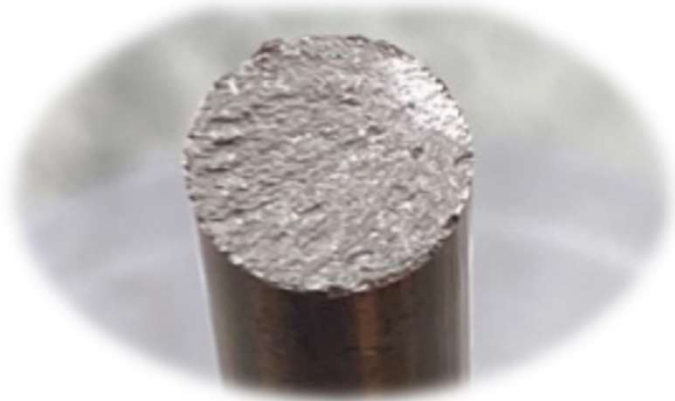

A → B



## DETOUR: INVESTIGATIONS

- Material
  - Different powder
    - Also Tool steel
- Mass spectrometry
  - In range, high Ti

Element	M300	Powder Specification	Specimen 2
Fe	Bal	Bal	Bal
Ni	18.36	17.0-19.0	17.12
Co	8.77	8.0-11.0	9.53
Mo	5.06	4.5-5.2	5.2
Ti	0.59	0.3-1.2	1.69
C	0.007	0.03 max	0.01
Al	0.1	0.15 max	0.138
Cr	0	0.5 max	0.13
Si	0.02	0.1 max	0.08
Mn	0.01	0.1 max	0.03
P	0.004	0.03 max	0.014
S	0.002	0.01 max	0.005
Cu	-	-	0.01
V	0	-	0.005
B	-	-	0.0024
Nb	0	-	0.02



## DETOUR: INVESTIGATIONS

- Material
  - Different powder
    - Also Tool steel
- Mass spectrometry
  - In range, high Ti
- Fractography
  - SEM

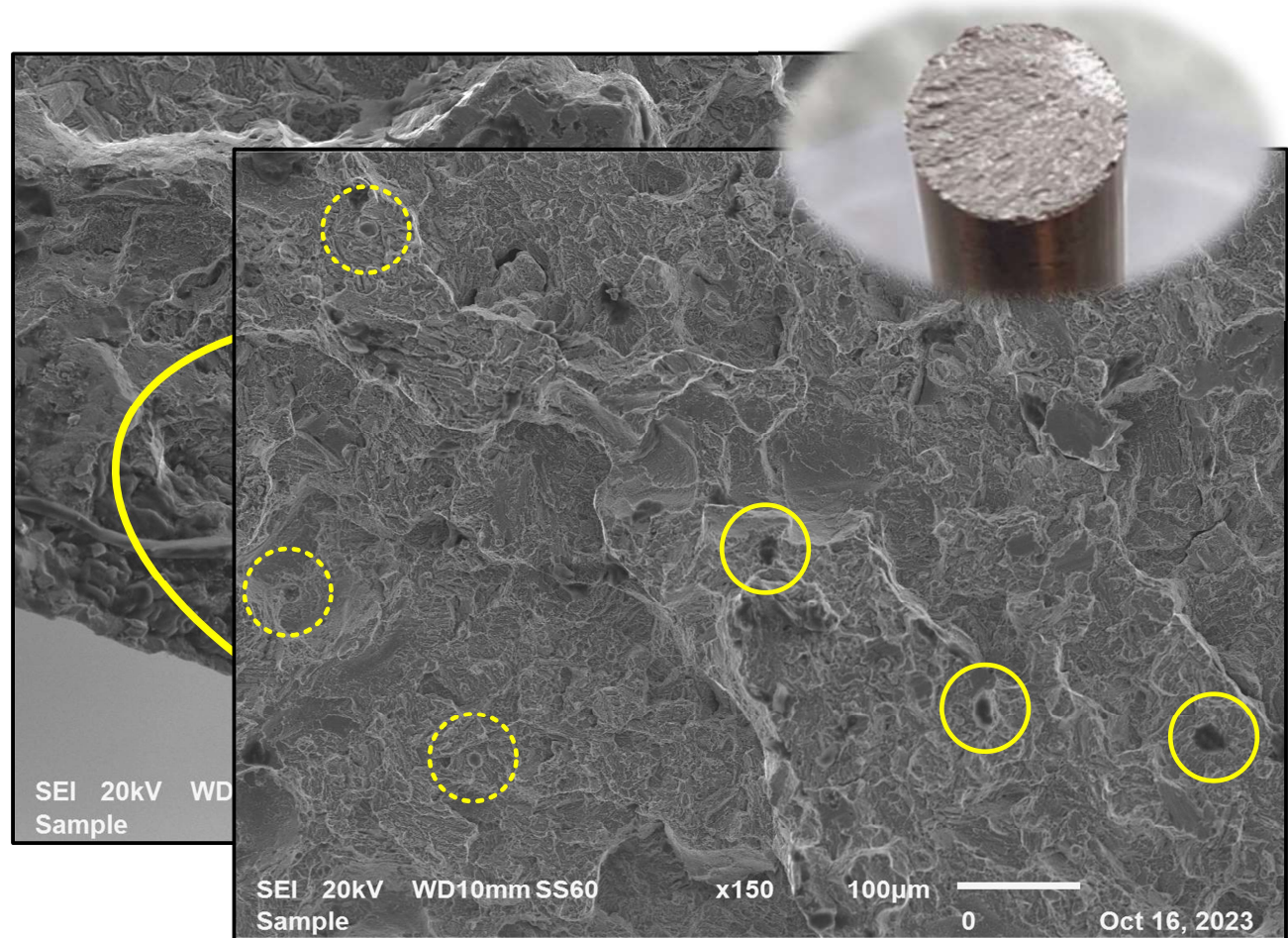

## ... BACK ON TRACK

---

- Continued with tests ...

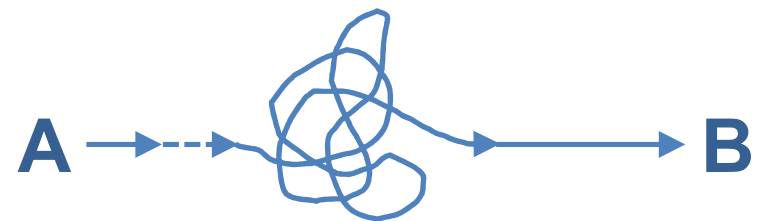

# TENSILE TEST RESULTS

## Annealed specimens

Specimen ID	Ultimate Tensile Stress [MPa]	Yield [MPa]	Elongation [%]	Diameter [mm]
AM Powder Spec	1 100	990	15	6.35 nominal
	± 100	± 100	± 5	
06 - HT	1 192	917	8.04	6.10
07 - HT	1 192	878	6.54	6.11
Mean	1 192	898	7.29	6.11

## Aged and annealed specimens

Specimen ID	Ultimate Tensile Stress [MPa]	Yield [MPa]	Elongation [%]	Diameter [mm]
AM Powder Spec	2 105	2 100	2	-
23 - A	1 497	-	0.17	6.13
02 - A	1 489	1 026	0.46	6.11
01 - A	1 709	-	0.13	6.12
Mean	1 565	1 026	0.25	6.12
Standard Dev	125	-	0.18	0.01



# FATIGUE RESULTS

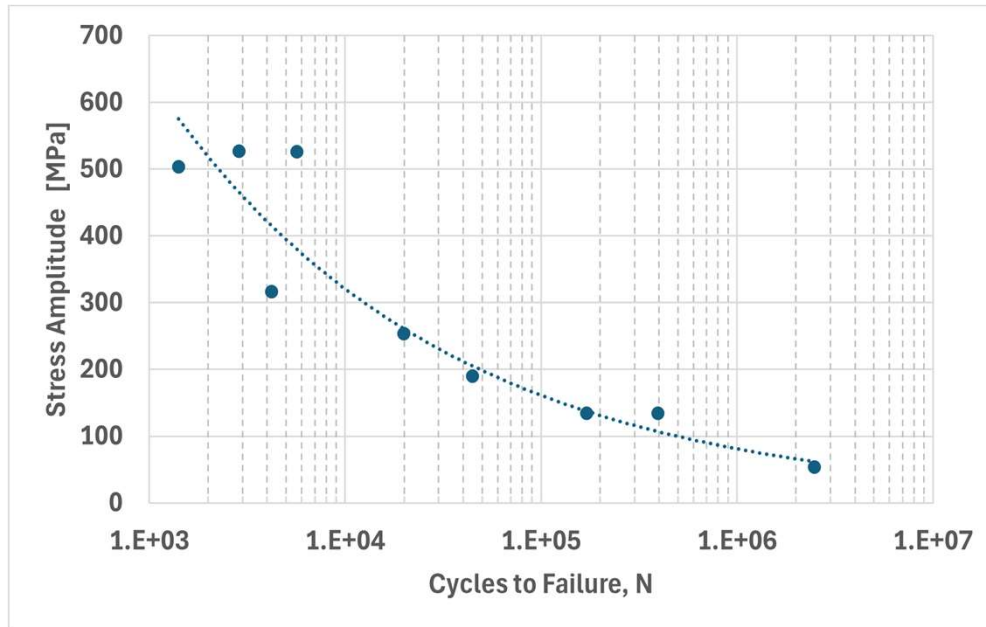

S-N curve for aged AM Tool Steel

- Aged specimens fatigue tested
- Comparable results, slightly lower
- Some scatter at higher loads



## SUMMARY

---

- Annealing followed by ageing caused a **significant under-performance** in the UTS compared to the published AM specifications:
  - when aged
    - matching when not aged
- An **S-N curve** was generated for aged, grown tool steel

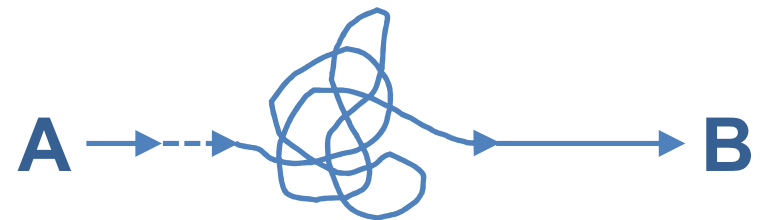

## FURTHER WORK

---

- Already completed
  - Classical vs AM HT
  - Sensitivity to aging temperature
- In process
  - Interaction with machine operators and powder suppliers
  - Repeat the tests: Tensile then fatigue

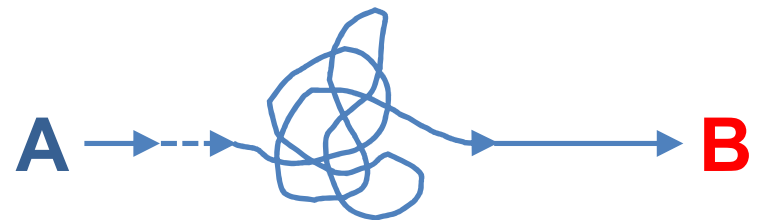



# CSIR

Touching lives through innovation

