

TRANSPORTATION RESEARCH

CIRCULAR

Number E-C139

September 2009

Use of Accelerated Pavement Testing to Evaluate Maintenance and Pavement Preservation Treatments

TRANSPORTATION RESEARCH BOARD
OF THE NATIONAL ACADEMIES

**TRANSPORTATION RESEARCH BOARD
2009 EXECUTIVE COMMITTEE OFFICERS**

Chair: Adib K. Kanafani, Cahill Professor of Civil Engineering, University of California, Berkeley

Vice Chair: Michael R. Morris, Director of Transportation, North Central Texas Council of Governments, Arlington

Division Chair for NRC Oversight: C. Michael Walton, Ernest H. Cockrell Centennial Chair in Engineering, University of Texas, Austin

Executive Director: Robert E. Skinner, Jr., Transportation Research Board

**TRANSPORTATION RESEARCH BOARD
2009–2010 TECHNICAL ACTIVITIES COUNCIL**

Chair: Robert C. Johns, Director, Center for Transportation Studies, University of Minnesota, Minneapolis

Technical Activities Director: Mark R. Norman, Transportation Research Board

Jeannie G. Beckett, Director of Operations, Port of Tacoma, Washington, *Marine Group Chair*

Paul H. Bingham, Principal, Global Insight, Inc., Washington, D.C., *Freight Systems Group Chair*

Cindy J. Burbank, National Planning and Environment Practice Leader, PB, Washington, D.C., *Policy and Organization Group Chair*

James M. Crites, Executive Vice President, Operations, Dallas–Fort Worth International Airport, Texas, *Aviation Group Chair*

Leanna Depue, Director, Highway Safety Division, Missouri Department of Transportation, Jefferson City, *System Users Group Chair*

Robert M. Dorer, Deputy Director, Office of Surface Transportation Programs, Volpe National Transportation Systems Center, Research and Innovative Technology Administration, Cambridge, Massachusetts, *Rail Group Chair*

Karla H. Karash, Vice President, TranSystems Corporation, Medford, Massachusetts, *Public Transportation Group Chair*

Edward V. A. Kussy, Partner, Nossaman, LLP, Washington, D.C., *Legal Resources Group Chair*

Mary Lou Ralls, Principal, Ralls Newman, LLC, Austin, Texas, *Design and Construction Group Chair*

Katherine F. Turnbull, Executive Associate Director, Texas Transportation Institute, Texas A&M University, College Station, *Planning and Environment Group Chair*

Daniel S. Turner, Professor, University of Alabama, and Director, University Transportation Center for Alabama, Tuscaloosa, *Operations and Maintenance Group Chair*

TRANSPORTATION RESEARCH CIRCULAR E-C139

Use of Accelerated Pavement Testing to Evaluate Maintenance and Pavement Preservation Treatments

Full-Scale and Accelerated Pavement Testing Committee
Transportation Research Board

September 2009

**Transportation Research Board
500 Fifth Street, NW
Washington, DC 20001
www.TRB.org**

TRANSPORTATION RESEARCH CIRCULAR E-C139

ISSN 0097-8515

The **Transportation Research Board** is one of six major divisions of the National Research Council, which serves as an independent adviser to the federal government and others on scientific and technical questions of national importance. The National Research Council is jointly administered by the National Academy of Sciences, the National Academy of Engineering, and the Institute of Medicine. The mission of the Transportation Research Board is to provide leadership in transportation innovation and progress through research and information exchange, conducted within a setting that is objective, interdisciplinary, and multimodal.

The **Transportation Research Board** is distributing this Circular to make the information contained herein available for use by individual practitioners in state and local transportation agencies, researchers in academic institutions, and other members of the transportation research community. The information in this Circular was taken directly from the submission of the authors. This document is not a report of the National Research Council or of the National Academy of Sciences.

Design and Construction Group

Mary Lou Ralls, *Chair*

Pavement Management Section

Thomas J. Kazmierowski, *Chair*

Full-Scale and Accelerated Pavement Testing Committee

Bouzid Choubane, *Chair*

Imad L. Al-Qadi
Don R. Alexander
Haley P. Bell
Nick I. Burmas
Nicolaas F. Coetzee
Edel R. Cortez
Brian Keith Diefenderfer
Louw du Plessis
Navneet Garg
Salil Gokhale

Roger L. Green
John T. Harvey
Gordon F. Hayhoe
Frederick Hugo
David Jones
William King, Jr.
Joe P. Mahoney
Amy Epps Martin
Angel Mateos

Tommy E. Nantung
Raymond "Buzz" Powell
Jorge A. Prozzi
Stefan A. Romanoschi
Elzbieta Sadzik
Kieran G. Sharp
Per Ullidtz
Kim A. Willoughby
Leif G. Wiman
Benjamin James Worel

Stephen F. Maher, *TRB Staff Representative*

Transportation Research Board
500 Fifth Street, NW
Washington, DC 20001
www.TRB.org

Glenda J. Beal, Production Editor; Jennifer Correro, Proofreader and Layout

Foreword

T*ransportation Research Circular E-C139: Use of Accelerated Pavement Testing to Evaluate Maintenance and Pavement Preservation Treatments* stems from the session, Assessment of Maintenance Treatments via Accelerated Pavement Testing, at the 86th Annual Meeting of the Transportation Research Board in January 2007. The session's moderator, John T. Harvey of the University of California Pavement Research Center, has provided an introduction to the Circular and has assembled the four papers that were presented by the authors at the meeting.

Contents

Introduction	1
<i>John T. Harvey</i>	
Accelerated Pavement Testing Experiment to Assess the Use of Modified Binders to Limit Reflective Cracking in Thin Asphalt Concrete Overlays	11
<i>D. Jones and John T. Harvey</i>	
Performance of Maintenance Treatments Under Accelerated Loading Facility Testing	32
<i>Tim C. Martin and Kieran G. Sharp</i>	
Use and Application of Accelerated Pavement Testing in Pavement Preservation Research	49
<i>W. Steyn</i>	
Minnesota Road Research Project Mainline Maintenance Observations and Test Track Lessons Learned, 2003–2006	60
<i>Benjamin J. Worel and Timothy R. Clyne</i>	

Introduction

JOHN T. HARVEY

University of California Pavement Research Center

Accelerated pavement testing (APT) has predominantly been used for understanding pavement behavior for design and rehabilitation of pavements, with less emphasis on maintenance and pavement preservation applications. This has primarily been driven by need, and partly by the assumption that APT is not suited to maintenance and pavement preservation treatments due to the low test speeds. However, with road authorities in much of the world spending considerably more on maintenance and pavement preservation than new construction, the use of APT has been explored as a means of providing rapid comparison and evaluation results that can aid in the selection of optimal treatments. The purpose of TRB's 86th Annual Meeting Session 594 (presented in 2007) was to present and discuss experience where APT has been successfully used for the assessment of pavement preservation and maintenance strategies.

It is important to note that there is a fundamental difference in the definition of "maintenance and preservation" versus "rehabilitation" in different countries for asphalt pavements. In many countries, particularly those in the southern hemisphere, a 45-mm asphalt overlay on an existing pavement would be considered to be rehabilitation because existing asphalt layers are of similar thickness and the overlay would be adding significant structural capacity to the pavement. In many other countries, and for the table at the end of this summary, it is assumed that a 45-mm overlay is thin compared with the thickness of the existing asphalt layers; it therefore does not significantly increase structural capacity and is intended primarily to seal the surface. If this overlay is placed on a pavement with relatively thick existing asphalt layers before the appearance of much cracking, then it can be considered a "preservation" treatment, and a succession of these overlays placed ahead of the appearance of significant cracking will build up increased structural capacity with time. All agencies use various treatments besides asphalt overlays to reseal asphalt pavements and restore functional properties (i.e., friction, ride quality).

Similarly, there can be some disagreement regarding what is maintenance or preservation versus rehabilitation for concrete pavements. In particular, load transfer restoration can potentially be considered as either, depending on agency policy.

The following is a summary highlighting some of the information shared at the session with regard to the use of APT to evaluate maintenance and pavement preservation treatments. This information was gathered from the papers presented, a discussion held after the presentations between the panel of presenters and the audience, and additional comments from an *ad hoc* critical review of the papers and this summary by members and friends of TRB's Full-Scale and Accelerated Pavement Testing Committee. It is intended that these ideas be used to motivate and better plan future APT research for evaluation of maintenance and pavement preservation treatments, and improve the quality and usefulness of results from APT in this area.

Session 594 was sponsored by TRB's Full-Scale and Accelerated Pavement Testing Committee. The work of the committee and its friends in developing the session, participating in it, and reviewing this work is acknowledged.

PLANNING OF THE APT EXPERIMENT

Most APT experiments are designed to complete two objectives:

1. Comparison of the performance of a treatment or treatments with a control section (either a section with no treatment or a section with a treatment with well-established field performance), and with each other if there are multiple treatments in the experiment. This requires that variables other than the treatment must be fixed across all sections, including underlying structural capacity, climate, and traffic.

2. Providing performance data under controlled climate and loading conditions for calibration of models. The calibrated models can then be used to extrapolate the APT results to field performance, not only at the project level but also at the network level.

Completion of the first objective is essential for APT to provide benefits. Completion of the second objective increases the benefits of APT.

In all cases, the first and most critical element of the successful application of APT is to determine what questions need to be answered. This needs to be agreed upon and documented before the experiment design and test plan are discussed and developed.

The questions of interest need to be answerable with APT, and may depend on the type of facility. In many cases test tracks may be more suitable because they use longer test sections, traffic moves faster and includes drive wheels, and overloads are not used. The primary limitations of APT for maintenance and pavement preservation treatment evaluation, as summarized by Steyn in his paper for this session, are as follows:

- The effect of riding quality can not be quantified accurately, especially when APT is performed with machines (e.g., heavy vehicle simulator accelerated loading facility) as opposed to real traffic on test tracks (e.g., MnROAD and National Center for Asphalt Technology (NCAT) at Auburn University), due to the relatively short pavement sections evaluated and the load application method utilized on some devices (controlled constant load levels). It should be noted that Martin and Sharp did measure longitudinal profile and roughness in the experiment described in their paper in the session.

- The loading speed of most APT devices is lower than conventional traffic and higher speed effects relevant to maintenance and pavement preservation treatments (i.e., whipping of aggregate from a new surfacing due to high speeds) can thus not be simulated correctly. This is especially true for APT machines and less true for test tracks.

- Test sections are often short and the effects of constructing such short preservation options can lead to undesirable and unrepresentative construction deficiencies.

- The effect of cornering, acceleration, and deceleration cannot be assessed.

PERFORMANCE AND FAILURE MEASURES

Typical performance measures for APT on maintenance and pavement preservation treatments depend on the treatment type. Comparison and failure criteria based on the selected performance criteria can be defined in the experiment plan. Examples are provided in the papers presented in the session.

CONDITION OF THE UNDERLYING PAVEMENT

The condition of the pavement prior to placement of the maintenance treatment is an important issue to consider. The desired condition will depend on the question to be answered by the APT experiment. Support considerations are discussed for a broad range of experiments by Steyn, and specifically for each experiment in the papers in the session by Jones and Harvey, Martin and Sharp, and Worel and Clyne. Variables for underlying pavement condition include the structural capacity of the pavement, its previous exposure to the damaging effects of environment and traffic, and the extent of distresses on the surface of the pavement that may influence the distress mechanism of the treatment. For instance, the presence of surface cracking prior to placement of a seal or thin overlay may lead to reflection cracking.

CONDITIONING OF THE TREATMENT PRIOR TO LOADING

Equal conditioning of the treatments prior to loading, or as close to equal as possible, may be included in the experiment plan. This can include equal exposure to the environment after construction, or artificial conditioning using controlled climate conditions (water, temperature, exposure to sunlight, air, dust, trafficking, etc.).

Because most APT sections must be tested sequentially, some aging to permit early rapid changes to occur on all sections prior to loading is suggested. Otherwise, the first section tested may have had no aging before loading, and the last section tested may have aged weeks or months prior to loading.

LOADING

Standard loads (for example 40 kN per half axle) are typically used when testing maintenance and pavement preservation treatments to simulate actual loading conditions. Performance and failure in the field are often strongly influenced by variables other than load, and the effects of those variables would be overwhelmed by using overloads. Another reason why overloads cannot be used for APT of maintenance treatments is that models allowing extrapolation of results back to field conditions are generally not available and overloading changes the distress mechanisms from those experienced in the field.

In all cases, especially with APT machines, a “bedding-in” period is necessary, particularly with aggregate seal coats to ensure that the aggregate is properly embedded into the pavement before performance testing commences.

INSTRUMENTATION

Instrumentation is similar to that used for APT for structural damage. Depending on the distress mechanisms anticipated, this can include

- Temperature at surface and in-depth;
- Surface deflections;

- Below-surface deflections ;
- Below-surface stresses;
- Below-surface strains;
- Below-surface permanent deformation;
- Water contents in unbound layers;
- Suction in unbound layers;
- Transverse surface profile;
- Crack mapping; and
- Crack activity.

Additional instrumentation that may be of value for different maintenance treatments and distress mechanisms can include

- Noise measurements using on-board sound intensity before and after (30 mph);
- Surface texture and friction;
- Longitudinal surface profile;
- Transverse surface profile (rutting–shoving);
- Observation of stripping; and
- Splash and spray.

COMPARISON OF APT RESULTS WITH CONTROL AND FIELD SECTIONS

It is essential that control sections whose behavior is well understood be included in APT experiments so that the extended life benefits of pavement preservation treatments can be compared with the control and also with each other.

It is much more difficult to translate repetitions of APT wheel loads directly to field conditions, primarily because of the relatively short duration of the test, and controlled climate conditions (temperature and water) under which the APT will be conducted in order to evaluate specific distress mechanisms. The best approach appears to be that used by many APT operating agencies, which is to build and monitor long-term pavement performance (LTPP) test sections in parallel with the APT sections. APT provides an initial comparison between alternative treatments, and an “apples to apples” comparison under controlled support, climate, and load conditions. The LTPP sections provide a realistic estimate of life in the field. Results from APT can be used to refine LTPP results for differences in construction quality, underlying support, climate, and load conditions. However, aging of the binder needs to be taken into account for asphalt pavements and aggregate seal coats.

SUMMARY

The presentations and discussion from the session made it clear that APT does have applications for evaluation of maintenance and pavement preservation treatment. It was also clear that there are limitations to the application of APT to this area of pavement engineering, and that the limitations are different for test tracks and APT machines.

The following table summarizes the experience of the APT community in testing maintenance and pavement preservation treatments.

TABLE 1 Summary Experience of APT Community for Evaluation of Maintenance and Pavement Preservation Treatments

Treatment Distre	ss Mechanisms	APT Can Evaluate?		Concerns or Effects That Should Be Considered	Controls Needed if APT Machine Used	Where Has It Been Done Before?	References **
		Test Track	APT Machine				
Thin dense and gap-graded overlays	Cracking	Yes	Yes	Aging, extent of underlying cracking (if reflection cracking), wheel speed	Temperature, water	South Africa, California, Australia, NCAT	3,4,5,7,15; from Steyn (2); 3, 7
	Rutting	Yes	Yes	Wheel speed	Temperature, no water	South Africa, California, Australia, NCAT	3,4,5,7,15; from Steyn (2); 3, 7
	Shoving	No	No	Torsion from drive wheels	N/A		
	Ravelling	Yes	No	Aging, torsion from drive wheels, wheel speed	N/A		
	Moisture damage	Yes	Yes		Temperature, water	South Africa	9
Thin open-graded overlays	Cracking	Yes	Yes	Aging, extent of underlying cracking (if reflection cracking), wheel speed	Temperature, water	South Africa, New Zealand	5, 9
	Rutting	Yes	Yes	Wheel speed	Temperature, no water	South Africa, NCAT	9
	Shoving	No	No	Torsion from drive wheels	N/A		
	Ravelling	Yes	No	Aging, torsion from drive wheels, wheel speed	N/A New	Zealand	5
	Moisture damage	Yes	Yes	Wheel speed	Temperature, water	South Africa	9
	Closing of voids	Yes	Yes	Effects of waterborne and airborne debris	Temperature, grit, water		

(continued)

TABLE 1 (continued) Summary Experience of APT Community for Evaluation of Maintenance and Pavement Preservation Treatments

Treatment	Distress Mechanisms	APT Can Evaluate?		Concerns or Effects That Should Be Considered	Controls Needed if APT Machine Used	Where Has It Been Done Before?	References **
		Test Track	APT Machine				
High-friction epoxy surface treatment	Surface friction	Yes	No	Torsion from drive wheels, wheel speed	NA NCAT		
	Debonding Yes		No?	Wheel speed	NA NCAT		
Aggregate seal coats	Ravelling	Yes	No	Aging, torsion from drive wheels, wheel speed	NA South	Africa MnROAD	3,4,8,9; from Steyn (2); 10
	Cracking	Yes	Yes	Aging, extent of underlying cracking (if reflection cracking), wheel speed	Temperature, water	Australia, South Africa	3,4,8,9; from Steyn (2)
	Embedment, bleeding	Yes	Yes	Existing surface condition	Temperature, no water		
	Rutting	Yes	Yes	Wheel speed	Temperature, water	Australia, South Africa MnROAD	1,3,4,8,9; from Steyn (2)
Aggregate stabilization	Raveling and Potholes	Yes	No	Construction for short test cells, Wheel speed	Stabilization amounts, water	MnROAD	11
Slurry seals	Ravelling	Yes	No	Aging, torsion from drive wheels, wheel speed	N/A MnROAD		4
	Cracking	Yes	Yes	Aging, extent of underlying cracking (if reflection cracking), wheel speed	Temperature, water	MnROAD	4

(continued)

TABLE 1 (continued) Summary Experience of APT Community for Evaluation of Maintenance and Pavement Preservation Treatments

Treatment	Distress Mechanisms	APT Can Evaluate?		Concerns or Effects That Should Be Considered	Controls Needed if APT Machine Used	Where Has It Been Done Before?	References **
		Test Track	APT Machine				
Micro-surfacing	Ravelling	Yes	No	Aging, torsion from drive wheels, wheel speed	NA MnROAD		4,6
	Cracking	Yes	Yes	Aging, extent of underlying cracking (if reflection cracking), wheel speed	Temperature, water	MnROAD	4,6
	Rutting (when filling ruts)	Yes	Yes	Depth of existing rut, wheel speed	Temperature, water	MnROAD	4,6
Patching	Rutting	Yes	Yes	Wheel speed	Temperature, no water	South Africa, NCAT	10; from Steyn (2)
Crack sealants	Crack reappearance	Yes	Yes	Aging, extent of underlying cracking (if reflection cracking), wheel speed	Temperature MnROAD, NCAT		2,12,13
Fog seals	Rutting	Yes	Yes	Wheel speed	Temperature, no water		
	Top-down cracking	Yes	No?	Wheel speed	N/A		
Ultra thin white-topping	Cracking Yes		Yes		Water, temperature	MnROAD, Indiana, FHWA, Florida (in progress)	14,15,16
	Faulting	Yes	No?	Unidirectional traffic, wheel speed	Water, temperature	Indiana, FHWA, Florida	
	Debonding Yes		Yes		Temperature		
	Roughness Yes		Yes		Temperature		

(continued)

TABLE 1 (continued) Summary Experience of APT Community for Evaluation of Maintenance and Pavement Preservation Treatments

Treatment	Distress Mechanisms	APT Can Evaluate?		Concerns or Effects That Should Be Considered	Controls Needed if APT Machine Used	Where Has It Been Done Before?	References
		Test Track	APT Machine				
Jointed plain concrete pavement load transfer restoration	Load transfer efficiency (LTE)	Yes	Yes	Measure slab temperature when LTE is measured	Water California		8
	Faulting Yes		No	Unidirectional traffic, wheel speed	Water		
	Cracking Yes		Yes		Water	California	
	Debonding (backfill)	Yes	Yes		Water?		
Ultra-thin reinforced portland cement concrete	Cracking Yes		Yes		Water	South Africa	11 from Steyn (2)
	Pumping Yes		Yes	Wheel speed	Water		
	Debonding Yes		Yes		Temperature, water		
All treatments	Longitudinal profile*	Yes	No?	Wheel speed	Temperature, water	Australia, MnROAD, NCAT	1,4

* If APT machine, must link transverse profiles

**References (references were not provided for all projects).

Note: Table has been reviewed by staff from CSIR (South Africa); University of California; ARRB Group (Australia); Minnesota DOT; University of Canterbury (New Zealand); Florida DOT; Virginia DOT; Kansas State University; Federal Highway Administration; Indiana DOT; National Center for Asphalt Technology (Auburn University).

REFERENCES

1. Martin, T. C., and K. G. Sharp. Performance Maintenance Treatments Under Accelerated Loading Facility Loading. In *Transportation Research Circular E-C139: Use of Accelerated Pavement Testing to Evaluate Maintenance and Pavement Preservation Treatments*, Transportation Research Board of the National Academies, Washington, D.C., 2009, pp. 32–48.
2. Steyn, W. Use and Application of Accelerated Pavement Testing in Pavement Preservation Research. In *Transportation Research Circular E-C139: Use of Accelerated Pavement Testing to Evaluate Maintenance and Pavement Preservation Treatments*, Transportation Research Board of the National Academies, Washington, D.C., 2009, pp. 49–59.
3. Jones, D., and J. T. Harvey. Accelerated Pavement Testing Experiment to Assess the Use of Modified Binders to Limit Reflective Cracking in Thin Asphalt Concrete Overlays. In *Transportation Research Circular E-C139: Use of Accelerated Pavement Testing to Evaluate Maintenance and Pavement Preservation Treatments*, Transportation Research Board of the National Academies, Washington, D.C., 2009, pp. 11–31.
4. Worel, B. J., and T. R. Clyne. 2003–2006 Minnesota Road Research Project Mainline Maintenance Observations and Test Track Lessons Learned. In *Transportation Research Circular E-C139: Use of Accelerated Pavement Testing to Evaluate Maintenance and Pavement Preservation Treatments*, Transportation Research Board of the National Academies, Washington, D.C., 2009, pp. 60–69.
5. Alabaster and Fussell. Fatigue Design Criteria for Low Noise Surfacing. *Research Report 307*, Land Transport New Zealand, 2006.
6. MnROAD paper presented at TRB 9th International Conference on Low-Volume Roads, Austin, Texas, June 2007.
7. Sharp, K. G., J. R. Johnson-Clarke, and D. W. Fossey. A Review of the Australian ALF Program. Presented at International Conference on Accelerated Pavement Testing, Reno, October, 1999.
8. Harvey, J. T., A. Ali, D. Hung, J. Uhlmeyer, L. Popescu, D. Bush, K. Grote, J. Lea, and C. Scheffy. *Construction and Test Results from Dowel Bar Retrofit HVS Test Sections 553FD, 554FD and 555FD: US 101, Ukiah, Mendocino County*. UCPRC-RR-2003-03. California Department of Transportation. Pavement Research Center, Institute of Transportation Studies, University of California. 2003.
9. Rust, F. C., J. L. Du Plessis, et al. Heavy Vehicle Simulator Testing of Trial Sections for Caltrans. California Department of Transportation, Contract Report DPVT C/255, CSIR, Transportek, 1993.
10. Lukanen, E. *An Evaluation of Aggregate and Chip Seal Surfaced Roads at MnROAD*. Report MN/RC 1998-24, Minnesota Department of Transportation, 1998. http://mnroad.dot.state.mn.us/research/MnROAD_Project/MnRoadReports/MnRoadOnlineReports/1998-24.pdf.
11. Johnson, G., and D. Baker. *Evaluation of Aggregate Sections at Mn/ROAD*. Report MN/RC 2000-29. Minnesota Department of Transportation. Aggregate Seal Coats and Aggregate Stabilization. Minnesota Department of Transportation, 2000. http://mnroad.dot.state.mn.us/research/MnROAD_Project/MnRoadReports/MnRoadOnlineReports/2000-29.pdf.
12. Palmquist, D., B. Worel, and W. Zerfas. *2002 Mn/ROAD Hot-Mix Asphalt Mainline Test Cell Condition Report*. Minnesota Department of Transportation, 2002. http://mnroad.dot.state.mn.us/research/MnROAD_Project/MnRoadReports/MnRoadOnlineReports/2002_MnROAD_Hot_Mix_Asphalt_Mainline_Test_Cell_Condition_Report.pdf.
13. Zerfas, W., R. Mulvaney, and B. Worel. *MnROAD Mainline 2003 Maintenance Activities for Hot-Mix Asphalt Test Cells*. Minnesota Department of Transportation, 2003. http://mnroad.dot.state.mn.us/research/MnROAD_Project/index_files/pdfs/Zerfas_W.pdf
14. Burnham, T. *Construction Report for MnROAD Thin Whitetopping Test Cells 60-63*. Minnesota Department of Transportation, 2006. http://mnroad.dot.state.mn.us/research/MnROAD_Project/MnROADReports/MnRoadOnlineReports/Cell60-63_200618.pdf.

15. Burnham, T. *Forensic Investigation Report for Mn/ROAD Ultrathin Whitetopping Test Cells 93, 94 and 95*. Minnesota Department of Transportation, 2005. http://mnroad.dot.state.mn.us/research/MnROAD_Project/MnROADReports/MnRoadOnlineReports/2005-45.pdf
16. Transtec. Unpublished report for the CPTP-Innovative Pavement Research Foundation (IPRF) Task 3 on “Performance and Design of Whitetopping Overlays on Heavily Loaded Pavements”, final report prepared for FHWA.

Accelerated Pavement Testing Experiment to Assess the Use of Modified Binders to Limit Reflective Cracking in Thin Asphalt Concrete Overlays

D. JONES

J. HARVEY

University of California Pavement Research Center

This paper presents an overview of the application of accelerated pavement testing (APT) to the evaluation of thin overlays over cracked asphalt pavement. The paper presents the approach used to develop the test plan and its implementation to date (the testing is not yet completed). Conclusions are drawn regarding identification of failure criteria and design of the experiment to match APT results to pavement management system (PMS) results. Instrumentation is discussed. The need for forensic trenching after APT to identify distress mechanisms in individual layers is also discussed. An approach to relate cracking densities on short APT pavement sections to cracking measures on full-scale pavement as used in PMS condition surveys is also discussed.

California, like most other states in the United States, has a mature road network that requires ongoing maintenance and rehabilitation. On that part of the network surfaced with asphalt concrete (AC), fatigue cracking is a common distress, which is typically maintained by placing a thin overlay of dense-graded AC or gap-graded rubber AC. Milling of the upper 50 to 100 mm of the old wearing course may be carried out prior to overlaying to maintain pavement thickness. The life of these overlays depends on the extent of fatigue cracking in the original surface, and the support provided by the underlying layers. With a view to extending the life of overlays, a study comprising accelerated pavement testing (APT) and associated laboratory testing was initiated by the California Department of Transportation (Caltrans) and the University of California Pavement Research Center (UCPRC) to evaluate the reflection cracking performance of asphalt mixes used in the state. This work forms part of a larger test plan for modified-binder (MB) mixes under the guidance of the Caltrans Pavement Standards Team (PST) that includes laboratory, heavy vehicle simulator (HVS), and field test sections (*1*).

The main objective of this investigation is to compare the performance of three maintenance overlays using MB mixes against two control maintenance overlay mixes [dense-graded AC (DGAC) and gap-graded rubberized AC (RAC-G)] that represent typical practice currently used throughout California. The overlays were constructed over a uniform test pavement specifically prepared for the study, which was designed and constructed according to standard Caltrans procedure and specifications. The project is divided into three phases. In the first phase, the uniform test pavement, consisting of six test sections, was trafficked with a HVS to induce fatigue cracking on the AC layer. In the second phase, selected overlay mixes were placed to evaluate

- Rutting performance under HVS loading at high temperature and
- Reflection cracking (the expected failure mode) under HVS trafficking at moderate temperatures.

The third phase, run concurrently with the APT, entailed a comprehensive laboratory investigation to relate laboratory rutting and fatigue performance to performance under the HVS. Experiments were conducted on samples removed from the road, on field mix, laboratory compacted samples, and on laboratory-mixed, laboratory-compacted samples.

This paper summarizes the project experimental design, experiment construction, and APT to date. Laboratory testing is not discussed. Although the experiment is still running some early findings are also presented. The emphasis of this paper is intended to be on the types of measurements and analyses that will aid in assessing the performance of thin overlays on cracked pavements.

EXPERIMENT DESIGN

The experiment was designed in two main phases (Table 1) (2). In the first phase a uniform test pavement (410-mm Class II aggregate base with 90-mm DGAC surfacing) was constructed. Six HVS sections (8.0 x 1.0 m) were demarcated and then trafficked under controlled environmental conditions (20°C) to induce fatigue cracking. Loading was restricted to 60 kN to limit rutting. In the second phase, the cracked pavement was overlaid with six different overlays:

1. Half thickness (45 mm) MB4 gap-graded overlay;
2. Full thickness (90 mm) MB4 gap-graded overlay;

TABLE 1 Experiment Design

Phase Parameter		Setting
I. Cracking of underlying asphalt pavement	Tire: Speed: Trafficking pattern: Pavement temperature at 50 mm: Loading: Failure criteria:	11R22.5 steelbelt radial at 720 kPa pressure 2.1 m/s (7.5 km/h) Bidirectional, with wander 20°C 60 kN Cracking of 2.5 m/m ²
II. Rutting of overlays	Tire: Speed: Trafficking pattern: Pavement temperature at 50 mm: Loading: Failure criteria:	11R22.5 steelbelt radial at 720 kPa pressure 2.1 m/s (7.5 km/h) Unidirectional, channelized 50 C 60 kN 12.5-mm average rut
II. Fatigue of overlays	Tire: Speed: Trafficking pattern: Pavement temperature at 50 mm: Loading: Failure criteria:	11R22.5 steelbelt radial at 720 kPa pressure 2.1 m/s (7.5 km/h) Bidirectional, with wander 0–1,000,000 repetitions at 20°C >1,000,000 repetitions at 15°C 0–215,000 repetitions at 60 kN 215,000–410,000 repetitions at 90 kN 410,000–1,000,000 repetitions at 80 kN >1,000,000 repetitions at 100 kN Cracking of 2.5 m/m ² or 12.5-mm average rut

3. Half thickness MB4 gap-graded overlay with minimum 15% recycled tire rubber (referred to as “MB15” in this paper);
4. Half thickness MAC15TR gap-graded overlay with minimum 15% recycled tire rubber (referred to as MAC15 in this paper);
5. Half thickness RAC-G overlay, included as a control for performance comparison purposes; and
6. Full thickness (90 mm) DGAC overlay, included as a control for performance comparison purposes.

Precise survey techniques were used to ensure that the Phase II HVS fatigue testing sections were exactly above the Phase I sections. Separate rutting experiments were demarcated adjacent to the cracking experiments. The layout of the experiment is show in [Figure 1](#).

Instrumentation

Instrumentation of the test sections consisted of the following ([Figure 2](#)):

- Multidepth deflectometers (MDD) used to measure elastic vertical deflections and permanent vertical deformations at various levels in the pavement structure, relative to a reference depth located in the subgrade;
- Road surface deflectometer (RSD) used to measure elastic vertical deflections at the surface of the pavement;
- Laser profilometer and straight edge used to measure the transverse profile of the pavement surface to determine surface rutting;
- Thermocouples used to measure temperatures at various depths in the asphalt bound materials; and
- Time domain reflectometer: used to monitor the changes in water content in the unbound layers just outside the trafficked area during testing of the section.

The following testing was also undertaken:

- Digital crack imaging used to measure surface cracking;
- Falling-weight deflectometer (FWD) used to measure elastic vertical deflections at the surface of the pavement before and after HVS testing and on areas not trafficked to monitor asphalt aging and seasonal changes in unbound layers moduli;
- Dynamic cone penetrometer (DCP) used to measure the relative shear resistance of unbound layers; and
- Trenching to determine final rut depths in each layer and assess final condition of pavement layers.

HVS Configuration

In the second phase, the rutting experiment was carried out first to assess susceptibility of the various mixes to this distress in the early life of the overlay and before aging influenced performance. Fatigue testing followed. Loads were limited to 60 kN and temperature maintained at 20°C in the first phase to avoid excessive rutting and to promote fatigue cracking. Traffic was channelized and high

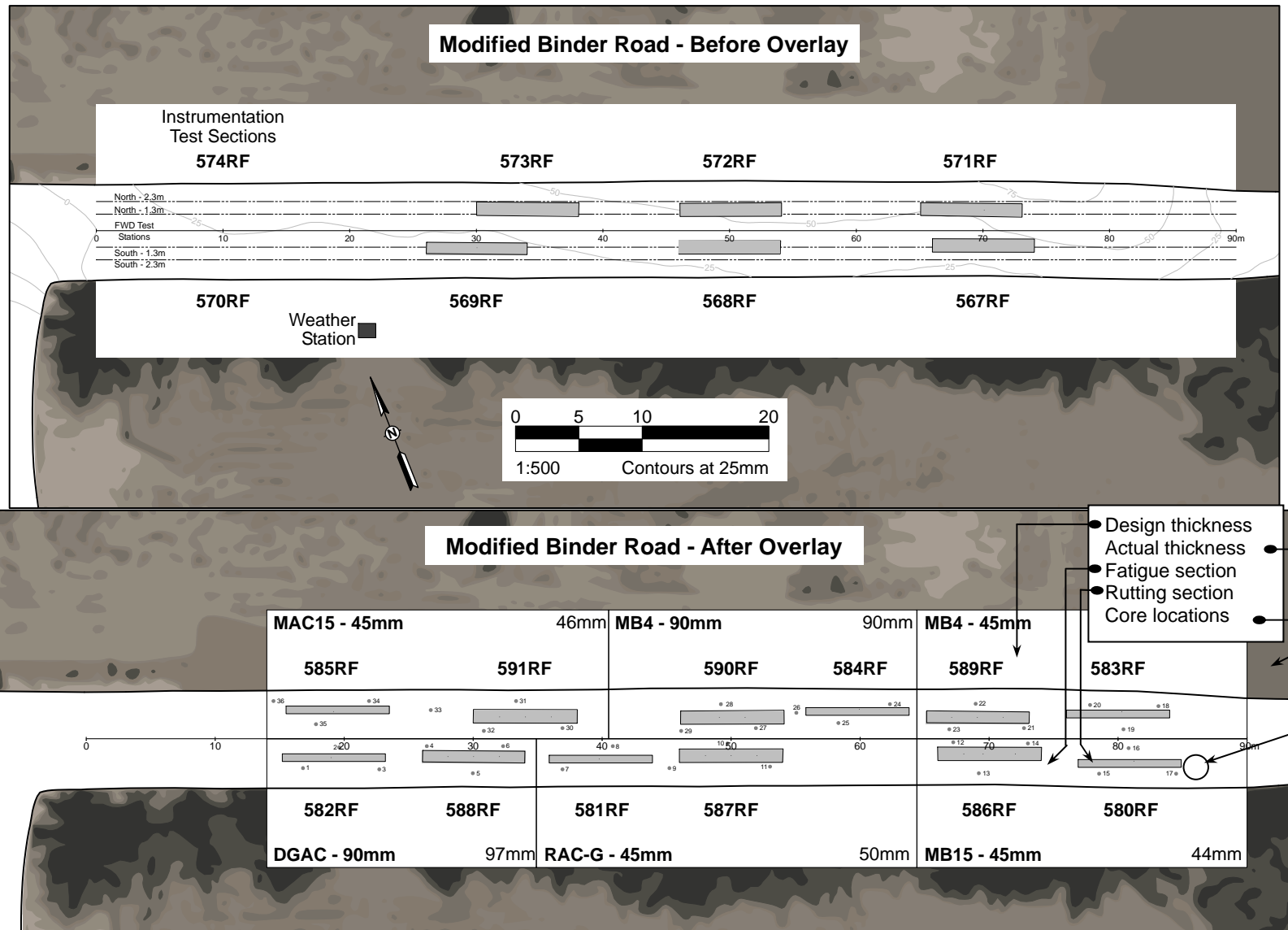

FIGURE 1 Layout of MB road project.

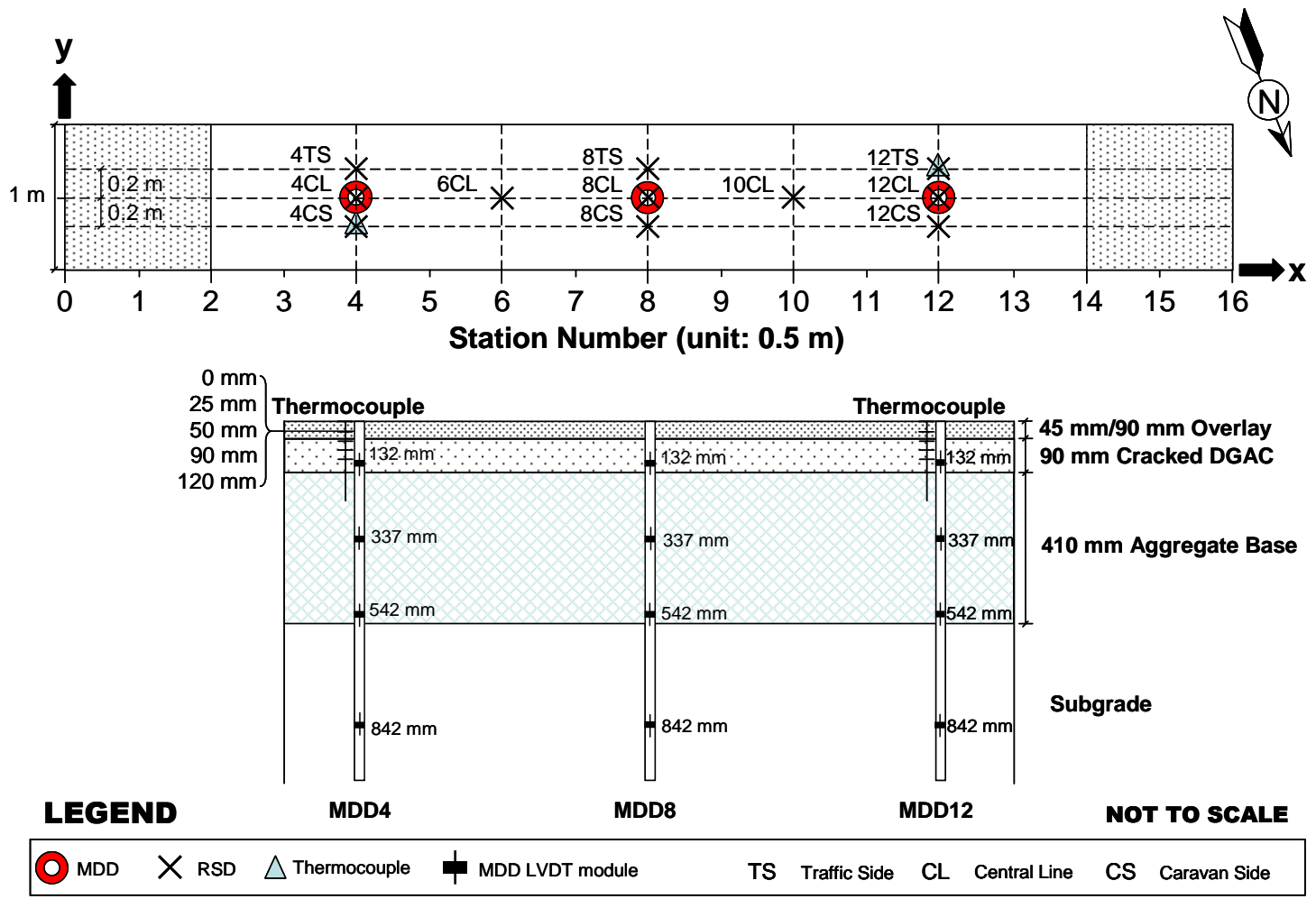

FIGURE 2 Location of instruments.

temperatures were maintained in the second phase rutting tests to evaluate rutting performance of the asphalt layers. Loads were limited again, to minimize rutting in the unbound layers. Overloads and moderate temperatures were used in the second phase fatigue tests to obtain reflection cracking performance and to include unbound layers rutting with the different overlays in the distress mechanism evaluation.

PAVEMENT DESIGN

The pavement for the first phase of HVS trafficking was designed according to the Caltrans Highway Design Manual Chapter 600. Design thickness was based on a tested subgrade R-value of 5 and a Traffic Index of 7 (~131,000 equivalent single-axle loads) (3). The pavement design for the test road is illustrated in Figure 3. A limited mechanistic analysis was conducted to ensure that subgrade rutting would be minimal under HVS trafficking. For the worst case conditions of soft subgrade and cracked AC, subgrade deviator stress-to-shear strength ratios were estimated to be below 0.4 under a 40 kN load and below 0.5 under an 80 kN load—considered sufficient to limit permanent deformation from the subgrade (3).

EXPERIMENT CONSTRUCTION

The existing subgrade was ripped and reworked to a depth of 200 mm, and compacted to meet Caltrans standard specifications (3). The aggregate base was constructed to meet the Caltrans compaction requirements for Class 2 aggregate base. Recycled construction waste was used per Caltrans specifications.

The DGAC layer consisted of a DGAC with AR-4000 binder and aggregate gradation limits following Caltrans 19-mm maximum size coarse gradation (3). The preliminary as-built mean air-void content was found to be 9.1% with a standard deviation of 1.8%. Final air-void contents, and the effects of traffic compaction, will be determined after all HVS testing is completed. Extensive DCP and FWD testing was carried out on the individual layers during pavement construction to monitor pavement strength and modulus. In the DCP analysis, average penetration rates for the aggregate base and subgrade before placing the AC were 6.4 and 23.4 mm/blow respectively with standard deviations of 1.0 and 9.0 mm/blow respectively. After placing the AC layer, the average penetration rates in the aggregate base and subgrade were 2.4 and 17.8 mm/blow with standard deviations of 0.4 and 5.4 mm/blow. The DCP tests obtained after the AC layer was placed were conducted 5 months after completion of the project. The

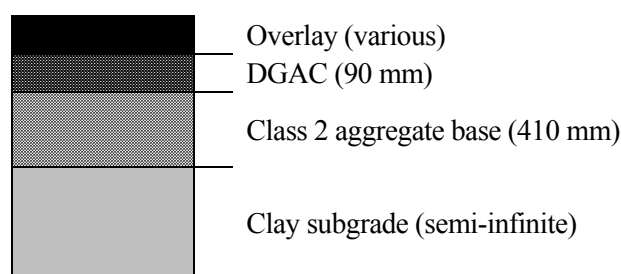

FIGURE 3 Pavement design for test road.

decrease in penetration rates over this period indicates a significant strengthening of the aggregate base over time, some of which was attributed to drying back of the material and possibly light cementation in the recycled concrete waste. Strengthening of the subgrade was observed at most test locations, possibly as a result of compaction of overlying layers during construction, and also to drying back and development of suction.

FWD testing was conducted at various stages during construction to study the effect of the subsequent overlay on the behavior of the pavement. FWD testing after placement of the DGAC wearing course, using loads of 22.2, 40, and 60 kN, showed substantial variability in moduli for the pavement layers, with the following average results:

- AC: 2,035 MPa (standard deviation, 602 MPa);
- Aggregate base: 284 MPa (standard deviation, 104 MPa); and
- Subgrade: 99 MPa (standard deviation, 37 MPa).

Differences in moduli under each section and their effects on performance will need to be reconciled through later analysis. This analysis will consist of calibration of mechanistic models using actual HVS results and pavements, and then simulation of the HVS pavements and other cases with uniform underlying conditions for the different overlays using the same models.

PHASE I HVS TESTING

Environmental Conditions

Accelerated pavement testing using the HVS was conducted on six subsections selected on the pavement test section (3) based on similar deflections.

The HVS test sections were tested in sequence at different periods during the year. [Figure 4](#) shows the sequence of HVS tests together with the average measured monthly air temperatures (°C) and precipitation amounts (mm/month) collected at a nearby weather station. Also in the figure are estimates of relative moisture content in the aggregate base and subgrade layers from TDRs embedded in the pavement during construction. The figure shows that HVS sections 567RF, 568RF, 573RF, 572RF, and 569RF were tested during the rainy season. Sections 571RF and 573RF were tested when the air temperatures were the highest. In terms of moisture content, [Figure 4](#) also shows that sections 567RF, 568RF, 572RF, and 569RF were tested when the aggregate base moisture content was relatively high ($\geq 80\%$ relative moisture content), and 571RF and 573RF when the aggregate base moisture content was comparatively lower ($< 80\%$). Subgrade moisture varied little throughout testing on all HVS test sections. Cognisance will be taken of these variations when interpreting performance.

Surface Deflections

Average surface deflections for each HVS test section measured by an RSD under a slow moving 60 kN wheel are presented in [Figure 5](#). Surface deflection increased with increasing load repetitions. Change in deflection with load repetitions is reduced for some sections. For example, for sections 571RF and 573RF, the deflections remain relatively constant in the range 200,000 to about 800,000 repetitions. This trend is also reflected in the crack density and surface rutting

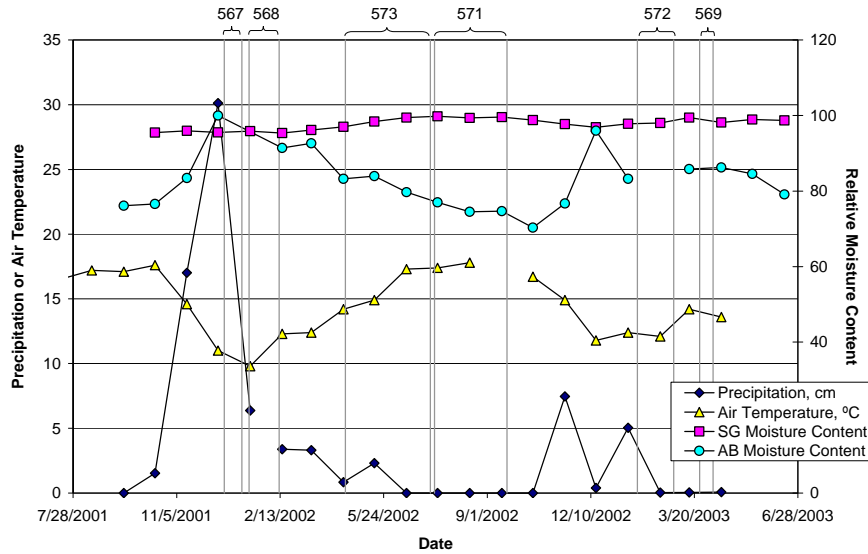

FIGURE 4 Sequence of HVS and climatic conditions during first phase of HVS testing.

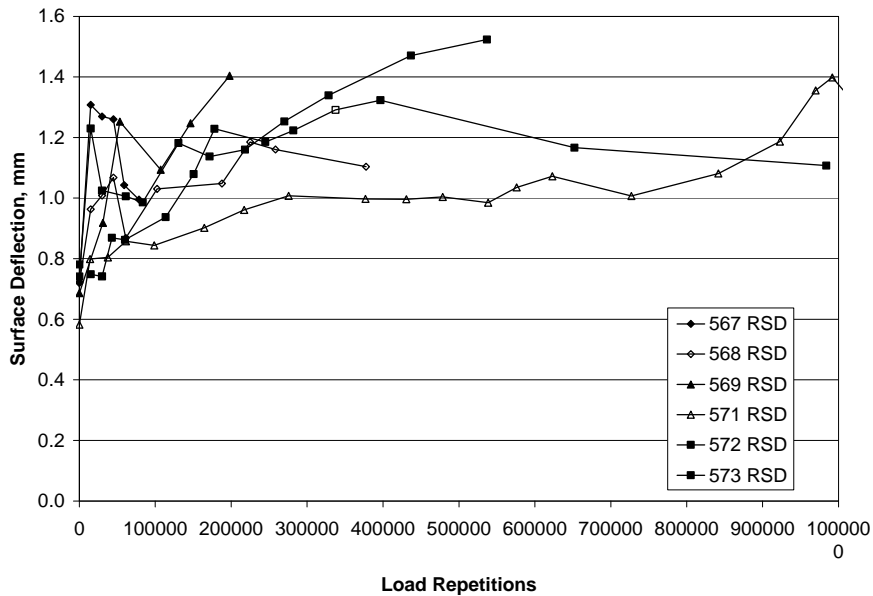

FIGURE 5 RSD surface deflections on Phase I HVS test sections.

versus load repetitions data. For Section 571RF, for example, crack development occurs at a relatively slow rate up to about 800,000 repetitions and then increases, as do deflections.

Surface Rutting

A summary of surface rutting data collected on the six HVS test sections is presented in Figure 6. The data show significant variability among the HVS tests. Sections 571RF and 573RF show

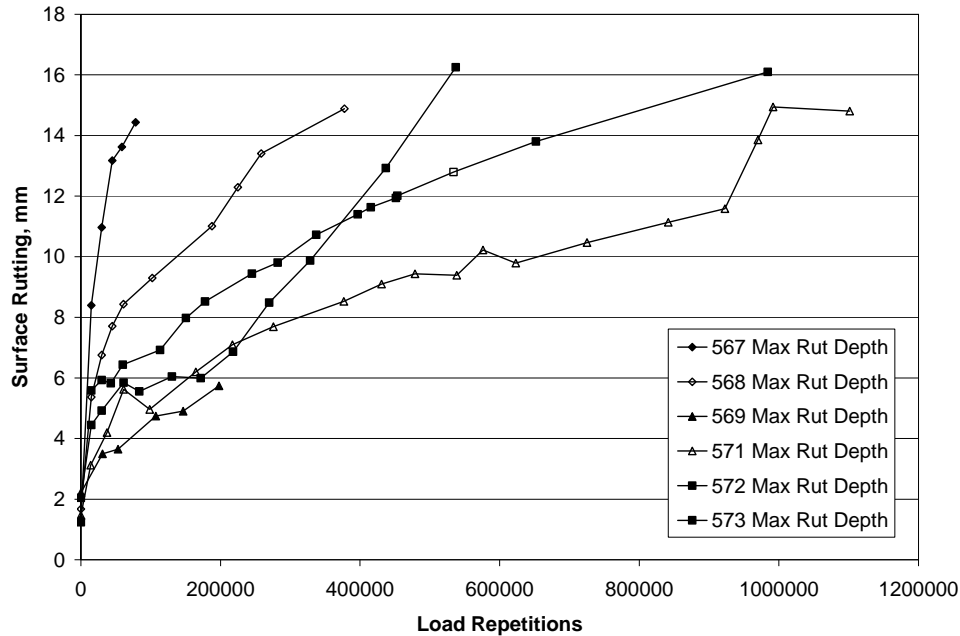

FIGURE 6 Summary of surface rutting performance after Phase I trafficking.

less permanent deformation and lower rates of rutting than the other sections. Based on the climatic and moisture content data presented, sections 571RF and 573RF developed less surface rutting because they were tested when the aggregate base had lower moisture content values. Sections 567RF, 568RF, 572RF, and 569RF experienced large rates of rutting believed to stem from plastic deformation in the aggregate base. Sections 572RF and 567RF had the largest rates of surface rutting. Although the average surface rutting for section 569RF was less than 6.0 mm, half of the sections exhibited surface rutting in the range of 12 mm. Final determination of rutting distribution between layers will be determined from trenching after completion of the HVS tests on the overlays.

Surface Cracking

Digital photographs of surface cracking were obtained at various time intervals during testing of each of the HVS test sections. These images were then processed to determine surface cracking at a given number of load applications. Figure 7 illustrates the surface cracks obtained at the end of HVS testing for each of the pavement sections. Surface crack patterns were different for each of the HVS sections: alligator cracks appeared in sections 567RF and 572RF; transverse cracks developed on sections 568RF, 571RF, and 573RF; and a combination of alligator cracking and transverse cracking was observed on section 569RF (half the section did not crack).

The type of crack pattern observed may be associated with the condition of the aggregate base and subgrade layers and is similar to patterns in surface rutting and surface deflection data. Sections 571RF and 573RF were tested during dry conditions. A weaker foundation typically produces more alligator cracking as seen in the remaining test sections except for section 568RF. Figure 8 summarizes surface cracking measurements with number of load applications for each HVS test section. HVS testing was continued beyond the 2.5 m/m² crack density failure

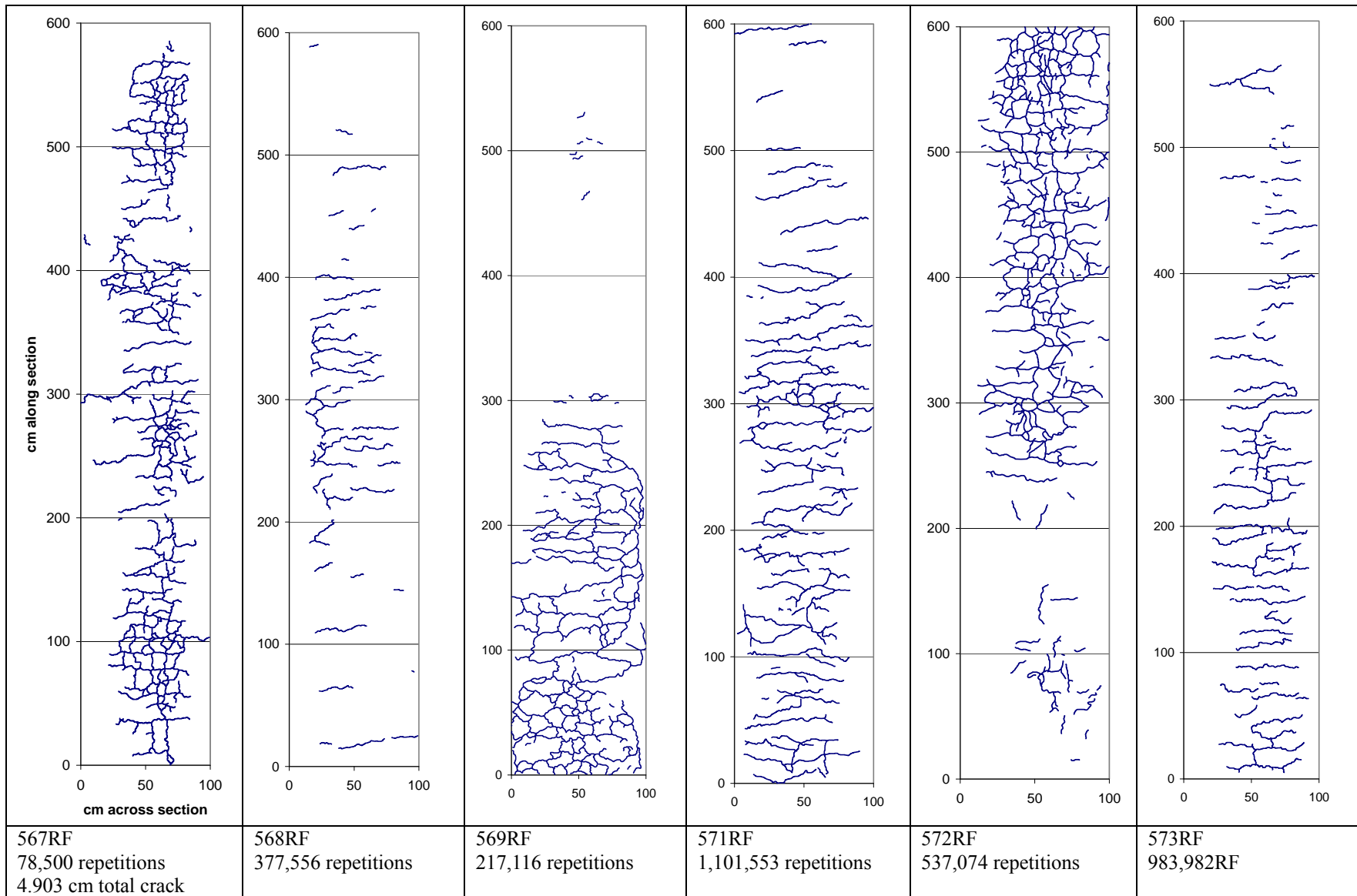

FIGURE 7 Surface cracking after Phase I trafficking.

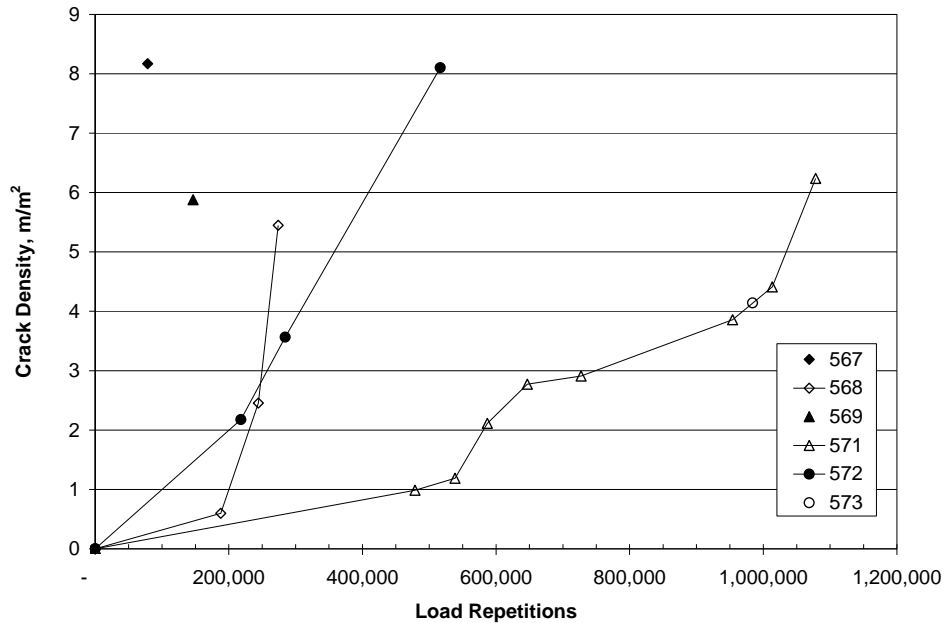

FIGURE 8 Summary of surface cracking after Phase I trafficking.

criterion to try and obtain similar crack densities on each section, and crack densities that would result in reflection cracking in the overlays.

FWD Testing

FWD testing was conducted on each section before and after HVS testing to monitor changes in layer moduli. There was a clear reduction in AC modulus after HVS testing for sections 567RF, 568RF, 569RF, and 572RF while section 573RF showed a slight reduction and section 571RF a slight increase in modulus. The reason for this increase or slight reduction probably relates to lower testing temperatures compared to measurements before HVS trafficking. Asphalt moduli temperatures should be corrected using deflections measured on the same day at several temperatures and an appropriate master curve from laboratory testing. Those corrections are currently underway.

AC modulus values were in the range of 4,000 to 7,000 MPa before HVS testing depending on temperature and from 2,000 to 4,000 MPa after HVS testing. The performance measures described in the previous sections relate reasonably well to these changes.

Modulus values for the aggregate base show a clear reduction in modulus over time for all sections. Values were in the range of 500 to 1,100 MPa before HVS testing and between 100 to 300 MPa after HVS testing. The agreement between intact modulus and modulus before HVS testing for each of the sections appear reasonable.

Modulus reductions for subgrade were not as significant as those for the asphalt concrete and aggregate base layers. This was attributed to the relatively constant subgrade moisture content.

Test Summary

Performance data for Phase I is summarized below in chronological order of HVS testing (Table 2). In summary, the ranking of HVS sections from worst to best performance was 567RF, 569RF, 572RF, 568RF, 571RF, and 573RF. The performance of the sections appears significantly influenced by the behavior of the aggregate base under conditions of high and low moisture content. Sections 571RF and 573RF were tested when the aggregate base was at lower moisture content than the other pavement sections. These sections showed less permanent deformation and less surface cracking than the other test sections.

OVERLAY DESIGN AND CONSTRUCTION

Overlay thicknesses were determined according to Caltrans Test Method CTM 356 using RSD data from the Phase I experiment and then adjusted to suit the requirements of the experiment. The following overlays were selected [HVS section designators are for rutting and fatigue respectively (see Figure 2)]:

- 567RF overlaid with 45-mm MB15 (HVS sections 580RF and 586RF);
- 568RF overlaid with 45-mm RAC-G control (HVS sections 581RF and 587RF);
- 569RF overlaid with 90-mm DGAC control (HVS sections 582RF and 588RF);

TABLE 2 Test Summary

	Test Section					
	567 568		573 571	572 569		
	HVS Testing					
Start date	12/21/2001	1/14/2002	4/17/2002	7/12/2002	1/24/2003	3/25/2003
Target AC temperature (°C)	20	20	20	20	20	20
Base condition	Wet	Wet	Dry	Dry	Wet	Wet
Load (kN)	60	60	60	60	60	60
Number of repetitions	78,500	377,556	983,982	1,101,553	537,074	217,116
ESALs	430,976	2,072,835	5,402,197	6,047,678	2,948,611	1,191,997
	General Performance					
Failure mode	Fatigue and Rutting	Fatigue and Rutting	Fatigue and Rutting	Fatigue and Rutting	Fatigue	Fatigue
Cracking density (m/m ²)	8.1	5.5	4.1	6.2	8.1	5.9
Final rut depth (mm)	13.7	14.2	15.3	14.1	8.8	3.8
	RSD					
	Deflection					
Temperature (°C)	20	20	20	20	20	20
Load (kN)	40	40	40	40	40	40
Average deflection (mm)	1.12	1.18	1.24	1.10	1.37	1.40
80th percentile (mm)	1.16	1.22	1.28	1.21	1.42	1.89
	FWD					
	Deflections					
80th percentile (mm)	0.211	0.237	0.323	0.39	0.622	0.586

- 571RF overlaid with 45-mm MB4 (HVS sections 583RF and 589RF);
- 572RF overlaid with 90-mm MB4 (HVS sections 584RF and 590RF); and
- 573RF overlaid with 45-mm MAC15TR (HVS sections 585RF and 591RF).

Mix designs were determined by Caltrans. The sections were constructed using conventional equipment and procedures. A tack coat was applied to the existing surface before the overlay. Binder, aggregate, and loose field mix were sampled for quality control and laboratory testing purposes. Cores were removed from areas where no HVS trafficking would take place to determine preliminary thicknesses and air void contents (Table 3). Exact layer thicknesses will be determined from cores and measurements in test pits after HVS testing has been completed on all sections.

Laboratory testing was carried out by Caltrans and UCPRC on samples collected during construction to determine actual binder properties, binder content, aggregate gradation, and air void content. Results will be presented in a subsequent paper once they have been verified from the test pit data.

PHASE II HVS TESTING

The second phase of HVS testing was carried out in two sub-phases, namely the rutting and fatigue experiments. At the time of preparing this paper, trafficking on all of the rutting experiments and five of the six fatigue experiments had been completed. The fatigue sections were precisely located on top of the Phase I sections, while the rutting experiments were placed in the most appropriate available space (4–8).

PHASE II HVS TESTING: RUTTING EXPERIMENT

Environmental Conditions

The target temperature for each test section was established at 50°C at a pavement depth of 50 mm. Trafficking was halted if the surface temperature deviated more than $\pm 4^\circ\text{C}$ from the target. The HVS test sections were tested in sequence over a period of 4 months (September to

TABLE 3 Overlay Thickness and Air Void Content (Preliminary)

Overlay Type	HVS Sections	Thickness (mm)		Air Void Content (%)	
		Average	Std Dev	Average	Std Dev
45-mm MB15	580RF and 586RF	44	9.7	3.1	1.0
45-mm RAC-G control	581RF and 587RF	50	6.1	8.8	1.3
90-mm DGAC control	582RF and 588RF	97	8.6	7.1	1.5
45-mm MB4	583RF and 589RF	48	4.5	6.5	0.6
90-mm MB4	584RF and 590RF	90	7.8	6.5	0.6
45-mm MAC15TR	585RF and 591RF	46	3.9	4.7	1.7

December) during which ambient temperatures and precipitation did not vary significantly. Some rainfall was recorded during the last two tests.

Surface Rutting

A summary of surface rutting data collected on the six HVS test sections under unidirectional 60 kN loading is presented in Figure 9. HVS testing was continued beyond the 12.5-mm rutting failure criterion in order to provide more complete data for performance model development and calibration. As with Phase I testing, the data show significant variability among the HVS tests. Sections 582RF (90-mm DGAC) and 584RF (90-mm MB4) rutted less than the 45-mm thick sections. The 45-mm MB4 rutted less than the RAC-G, which was unexpected. The 45-mm MB15 and MAC15 sections showed the least resistance to rutting.

At the time of preparing this paper, only one test pit had been excavated on the rutting sections. This pit, on the 45-mm MAC15 experiment, showed that all of the rutting occurred in the underlying 90-mm DGAC, and not in the overlay (Figure 10). This had been previously observed in thin rubberized overlays testing in a previous experiment (8).

This result shows that assessment of the high temperature rutting performance of thin overlays must be assessed by trenching. It has been found in a previous experiment, and in the trenching of the first rutting test in this experiment, that the rutting in pavements with thin overlays (less than 60 mm) often occurs in the AC beneath them. This is consistent with results of finite element analyses during a SHRP project.

Based on these findings, no further conclusions on rutting will be drawn until test pits have been excavated on all of the sections.

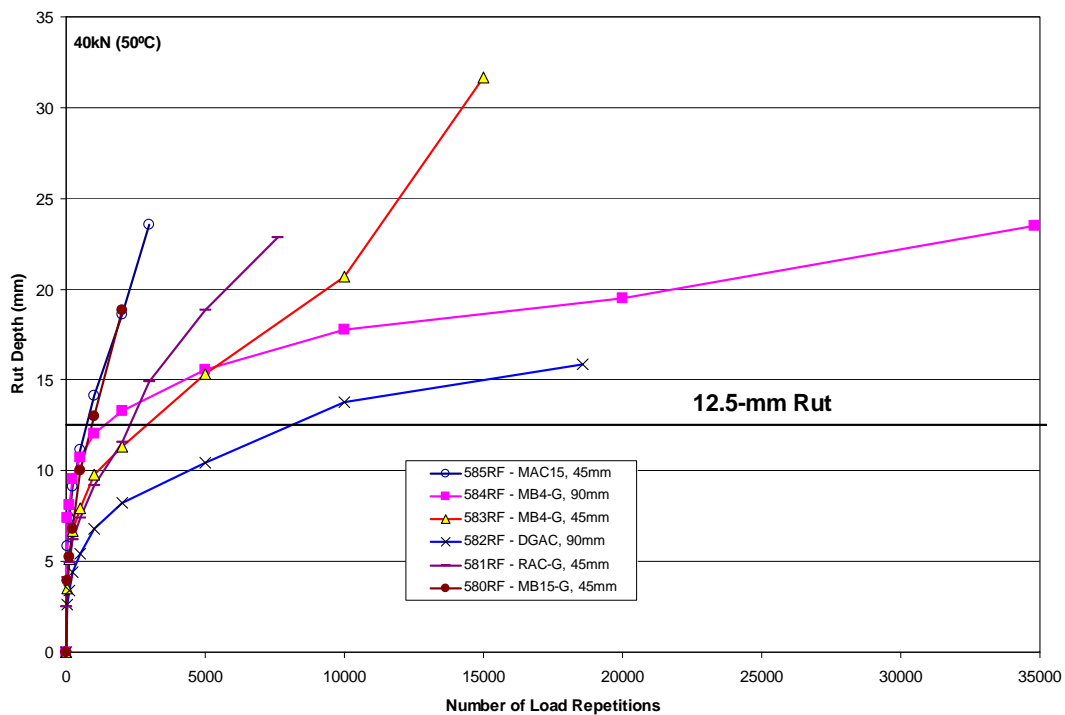

FIGURE 9 Summary of surface rutting experiment after Phase II trafficking.



FIGURE 10 Test pit face showing rutting pattern on 45-mm MAC15 and 90-mm DGAC.

PHASE II HVS TESTING: FATIGUE EXPERIMENT

Environmental Conditions

The target temperature for each test section was established at 20°C at a pavement depth of 50 mm for the first 1 million repetitions and thereafter at 15°C. Trafficking was stopped if the surface temperature deviated more than $\pm 4^\circ\text{C}$ from the target. As with the Phase I experiment, the subgrade was in direct contact with the natural water table, resulting in changes in water content caused by seasonal variations. The HVS test sections are being tested in sequence at different periods during the year. Test durations for the four of six tests completed have varied between 1.5 and 2.5 million repetitions and hence each individual test spanned both dry and wet and cooler and warmer conditions. Rainfall conditions for the first four tests are summarized in [Figure 11](#).

Details of the results of the overlay tests have not yet been reviewed by Caltrans, and thus cannot be presented in this paper. However, some general results are presented to help emphasize key elements of the testing and analysis that are need for assessment of the performance of thin overlays over cracked pavements.

Surface Deflections

Final average surface deflections for each HVS test section measured by an RSD under a slow moving 60 kN wheel ranged between 1,228 microns and 2,099 microns and are presented in [Figure 11](#). Ratios of final to initial surface deflection ranged significantly between the

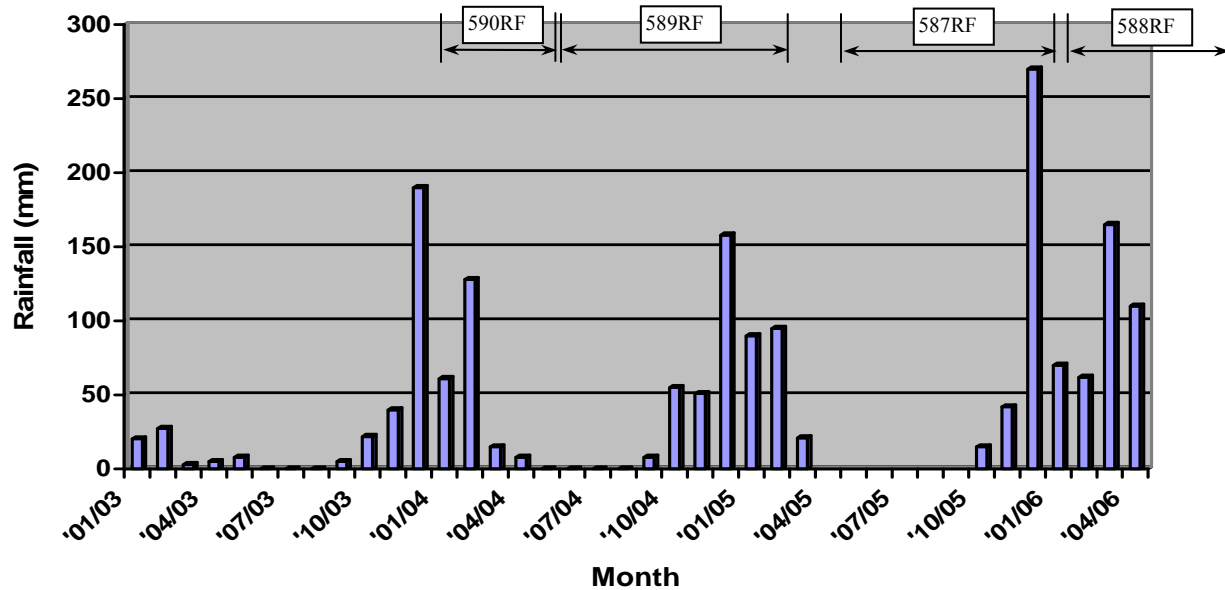

FIGURE 11 Rainfall during Phase II fatigue testing.

experiments. On the lower end, ratios were typically in the order of 2.0 to 3.0 for some overlays, while on the higher end, ratios were in the order of 4.5 to 11.6. Surface deflection increased with increasing load repetitions on all sections. Deflection varied along the length of each section depending on the crack pattern in the underlying section, with higher deflections measured over the most severely cracked areas. It is interesting to note that one overlay had the lowest deflection at the start of testing, but the highest on completion of testing. This section also had the lowest number of repetitions.

Ratios of final-to-initial in-depth elastic deflections on all sections, measured with MDDs, show that damage increased significantly at all depths in the pavement structure by the end of trafficking, with loss of stiffness highest in the area of most severe cracking in the underlying layer. Most deflection occurred in the surface layers and upper area of the base. Minimal deflection was recorded in the subgrade. There have been some problems with achieving solid anchorage of the MDDs in the soft clay below the test sections.

Considerations for the performance assessment that will need to be made include the following:

- Contribution of the thin overlays to reduction of surface deflections in cracked pavement;
- Damage in pavement caused by HVS loading, in terms of the ratio of final to initial surface deflection;
- Comparison of damage, as measured by deflection and back-calculated layer moduli (from RSD and FWD) with appearance of reflection cracking on the surface of the overlays (ratio of damage to crack propagation likely will give insight into the “toughness” of the overlays); and

- Damage in individual layers (from MDD elastic deflections), compared for thicker conventional (stiffer) overlays and thinner modified (softer) overlays (to provide a comparison of the protection to underlying layers and rutting of the unbound layers for the different overlays).

Surface Rutting

HVS testing has mostly been continued beyond the average 12.5-mm rutting failure criterion to better assess fatigue cracking and to provide more complete data for performance model development and calibration. The data show significant variability among the HVS tests. Deepest rut was always recorded over the most severely cracked area of the underlying layer and corresponded with weaker areas determined with the surface deflection measurements. Permanent deformation as measured with the MDDs indicated that most rutting occurred in the surface layers and the upper layers of the aggregate base. Based on the findings from the initial test pit discussed above, no further conclusions on rutting will be drawn until test pits have been excavated on all of the sections.

Surface Cracking

Digital photographs of surface cracking were obtained in a similar manner to that described in the Phase I testing discussion. [Figure 12](#) illustrates the surface cracks obtained at the end of one of the HVS tests (section 587RF), with the underlying crack pattern also shown. Surface crack patterns generally mirrored the pattern on the underlying layer. There have been clear differences in reflection cracking performance between the overlays.

It is important to identify the cracking mechanism, in order to correctly understand the behaviour of the overlays, both for practical reasons and for modeling. In this case, digital images of the cracking patterns in the overlay and the underlying pavement clearly show that the mechanism is reflection cracking. This will need to be confirmed by coring and checking of alignment of cracks in the cores. Some assessment of whether the cracks initiated at the top or the bottom of the overlay, or both, can be made from the cores, but cannot be conclusive. Modeling and judgement will have to be used to make that assessment until methods of imaging cracking beneath the surface become available.

If the mechanism was found to be bottom up fatigue cracking for some sections and reflection cracking for others, it indicates that the different types of overlays may need to be selected and designed by different criteria. The same is true if some overlays failed by top-down cracking as opposed to reflection or bottom-up cracking.

FWD Testing

FWD testing was conducted on each section before and after HVS testing to monitor changes in layer moduli. There was a clear reduction in asphalt concrete modulus after HVS testing on all sections tested to date. Back-calculated moduli will not be determined until accurate layer thicknesses can be determined from cores, which will be removed after completion of all testing.

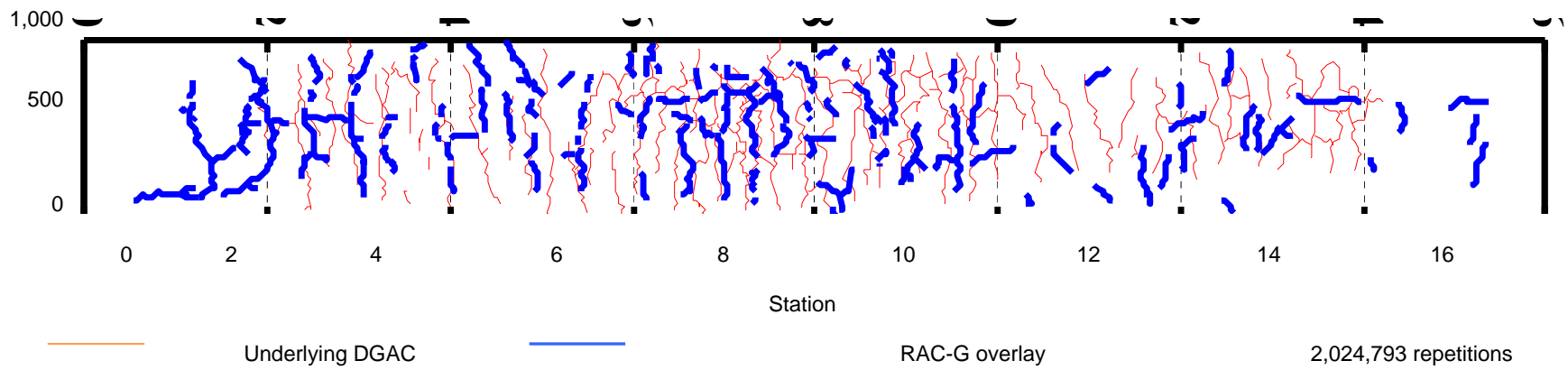

FIGURE 12 Surface cracking after Phase II trafficking showing cracking in both underlying asphalt and overlay.

CONSIDERATION FOR ANALYSIS OF OVERLAY PERFORMANCE

Differences in cracking densities, different support conditions and unequal distribution of cracking densities within sections (half cracked, half not cracked) will need to be accounted for in the analysis of the cracking performance of the overlays to be placed on top of them. Differences in crack densities in the underlying sections will need to be accounted for by changing the cracking performance measure for the overlays from crack density (measure of cracks per m² of section) to percent of existing crack density reflected into the overlay, as follows:

$$\% \text{ reflection cracking} = \text{crack density in overlay} / \text{crack density in underlying section}$$

To account for other differences in cracking distribution and underlying support, two steps will be taken in the analysis of the overlay performance once the testing is completed in April 2007.

1. Sections in which the pavement at one end performed differently from the other, such as 569RF and 572RF will be divided into more homogenous subsections during second-level analysis. The subsectioning will be based on cracking and rutting performance of the underlying layer, and statistical comparison of deflections and back-calculated layer moduli from FWD. Each subsection will then be analyzed as a separate test.

2. Mechanistic–empirical models of the pavement performance, specifically the reflection cracking and rutting performance, will be calibrated using MDD and RSD deflection measurements and permanent deformation measurements from the laser profilometer (surface) and MDD (subsurface) during the test, and final rut depths from post-test trenching. The models are included in a software program called CalME that uses a recursive updating procedure that permits comparison of deflections and stiffnesses during the course of the HVS test with the model results. This permits calibration of the models for the HVS tests using results from the duration of the test, rather than just the end point, thus modelling the damage process. Once the models are calibrated to match the performance on each subsection, the models will be run again using same underlying conditions for each overlay. This will provide a second assessment of the relative performance of the overlays, with the inevitable differences in the underlying conditions removed.

CONCLUSIONS

This experiment, although not complete, illustrates the benefits of using APT for assessing thin maintenance overlays on cracked AC pavement. Test results are expected to provide a valid comparison of the use of modified binders compared to conventional binders in terms of reflective cracking, rutting of the asphalt layers, and rutting of the unbound layers.

To date, no forensic evaluation has been undertaken. This is planned on completion of all testing. A full understanding of the pavement layer behavior and performance will be gained once this evaluation has taken place.

Conclusions drawn regarding the use of APT to assess the performance of different thin overlay strategies include the following:

1. Clear failure criteria must be selected, related to the pavement management objectives of the road agency, and typical field conditions under which the treatments being compared will be used. In this case, for thin overlays, cracking and rutting (high temperature and moderate temperature) criteria were used. Test conditions should be similar to those expected in the field.

2. Instrumentation and other measurement techniques used for APT to test structural designs can also be used for testing of thin overlays, including deflections (surface and in-depth), surface profiles, and cracking images.

3. Comparison of rutting performance of thin overlays must be assessed by trenching, and MDDs where feasible. In particular, much of the rutting under thin overlays may be related to the overlay stiffness and shear resistance, but if the overlays are less than 60 mm in thickness, much of the rutting will occur in underlying asphalt and unbound layers.

4. It is important to identify the cracking mechanism, reflection, bottom-up or top-down, in order to correctly understand the behaviour of the overlays, both for practical reasons and for modelling. Digital crack image comparison and coring will be used in this experiment. These techniques identify whether the cracks were reflective or not, but not the location of initiation. Modeling and judgement will have to be used to make that assessment until methods of imaging cracking beneath the surface become available.

5. Differences in cracking densities, different support conditions and unequal distribution of cracking densities within sections (half cracked, half not cracked) will need to be accounted for in the analysis of the cracking performance of the overlays to be placed on top of them. Differences in crack densities in the underlying sections will need to be accounted for by changing the cracking performance measure for the overlays from crack density (m of cracks per m² of section) to percent of existing crack density reflected into the overlay. Differences in underlying support conditions will be accounted for by sub-sectioning of the HVS sections based on deflections and cracking in the underlying pavement.

6. To account for other differences in cracking distribution and underlying support, two steps will be taken in the analysis of the overlay performance. The first step will consist of calibration of mechanistic-empirical damage models that use recursive updating of damage with HVS data, which will include consideration of the differences in the underlying pavements and construction differences in the overlays. The second step will be to use the calibrated models to simulate the performance of the overlays with uniform underlying conditions.

REFERENCES

1. *Generic Experimental Design for Product/Strategy Evaluation—Crumb Rubber Modified Materials*. Caltrans, Sacramento, Calif., 2005.
2. *Comparison of MB, RAC-G, and DGAC Mixes Under HVS and Laboratory Testing*. University of California Pavement Research Center, Davis and Berkeley, Calif., 2003.
3. Bejarano, M., B. Morton, and C. Scheffy. *Summary of Construction Activities and Results from Six Initial Accelerated Pavement Tests Conducted on Asphalt Concrete Pavement Section for Modified-Binder Overlay*. Report No. 2005.UCPRC-RR-2005-03. University of California Pavement Research Center, Davis and Berkeley, Calif., 2005.
4. Tsai, B., D. Jones, and J. Harvey. *Reflective Cracking Study: First-Level Report on HVS Testing on Section 590RF: 90-mm MB4 Overlay*. Report No. 2005.UCPRC-RR-2006-04. University of California Pavement Research Center, Davis and Berkeley, Calif., 2006.

5. Jones, D., R. Wu, J. Lea, and J. Harvey. *Reflective Cracking Study: First-Level Report on HVS Testing on Section 589RF: 45-mm MB4 Overlay*. Report No. 2005.UCPRC-RR-2006-05. University of California Pavement Research Center, Davis and Berkeley, Calif., 2006.
6. Wu, R., D. Jones, and J. Harvey. *Reflective Cracking Study: First-Level Report on HVS Testing on Section 587RF: 45-mm RAC-G Overlay*. Report No. 2005.UCPRC-RR-2006-06. University of California Pavement Research Center, Davis and Berkeley, Calif., 2006.
7. Jones, D., R. Wu, and J. Harvey. *Reflective Cracking Study: First-Level Report on HVS Testing on Section 588RF: 90-mm DGAC Overlay*. Report No. 2005.UCPRC-RR-2006-07. University of California Pavement Research Center, Davis and Berkeley, Calif., 2006.
8. Steven, B., D. Jones, and J. Harvey. *Reflective Cracking Study: First-Level Report on HVS Testing on Rutting Sections (Sections 580RF to 585RF)*. Report No. 2005.UCPRC-RR-2006-13. University of California Pavement Research Center, Davis and Berkeley, Calif., 2006.
9. Harvey, J., and L. Popescu. Accelerated Pavement Testing of Rutting Performance of Two Caltrans Overlay Strategies. In *Transportation Research Record 1716*, Transportation Research Board, National Research Council, Washington, D.C., 2000, pp. 116–125.

Performance of Maintenance Treatments Under Accelerated Loading Facility Testing

TIM C. MARTIN
KIERAN G. SHARP
ARRB Group Ltd.

About 85% of Australia's sealed arterial road network consists of unbound granular pavements and a thin bituminous surfacing, normally a chip seal. While these pavements are very cheap, compared with other pavement types, and capable of withstanding high traffic loads, their optimum performance is very much dependent on maintaining a surface at the desired level of service for road users. Most pavement management system (PMS) databases do not permit the development of models that predict the influence of various surface treatments on deterioration because of correlation problems with the data in PMS databases. Experimental pavement performance data are therefore needed to develop these road deterioration (RD) models that can discriminate between the various surface treatments so that maintenance treatments are selected to produce the lowest pavement life-cycle cost. The feasibility of using accelerated pavement testing to predict the influence of various surface treatments on deterioration was confirmed by pilot testing on an existing pavement with different types of surface treatment. A follow-up trial involving 10 experiments and various types of surface treatment on separate test pavements was undertaken under controlled environmental conditions using the Accelerated Loading Facility in an enclosure to control moisture environment. Pavement deterioration was measured in terms of the progression of rutting, roughness, and surface deflection. The deterioration data were used to estimate relative performance factors for rutting and roughness for a range of surface treatments under surface conditions varying from dry to continuously wet. The relative performance factors can be applied to the observed deterioration of given surface treatments to develop RD models that predict the influence of various surface treatments on deterioration. The data are supplemented by data being collected in various long-term pavement performance projects, including a project directed specifically at maintenance treatments. Although only thin bituminous surface treatments were used in the experimental testing, it would seem reasonable to expect that this form of testing could be extrapolated to thin asphalt surface treatments (≤ 50 mm) over flexible pavement bases. The accelerated load testing experiments appear to be a rapid means of determining the relative performance of various surface treatments applied to flexible pavement bases. It would be useful to compare the outcomes from this approach, and the resources involved, with those from a theoretical nonlinear finite element analysis based on laboratory material performance characterization.

The length of Australia's road network is about 800,000 km, of which only about one-third is sealed. However, about 90% of the total freight task is carried on this sealed road network. About 85% of Australia's sealed arterial road network consists of unbound granular pavements and a thin bituminous surfacing, normally a chip seal. While these pavements are very cheap compared to other pavement types, and capable of withstanding high traffic loads, their optimum performance is very much dependent on maintaining a serviceable surface if the desired level of service is to be provided to road users.

The selection and timing of the appropriate surface treatment results in a reduction in pavement deterioration, and an associated reduction in pavement life-cycle costs, because relatively costly rehabilitation or reconstruction works can be deferred. However, the efficient management of the sealed road network in terms of maintenance regimes relies heavily on the development of models that accurately predict the influence of various surface treatments on road deterioration (RD). The

development of these models in turn relies on the collection of experimental performance data because the observational data included in most pavement management systems are correlated.

Until 1999, the Australian Accelerated Loading Facility (ALF) had been mainly used to address design and construction issues or to compare the relative performance of unbound and bound pavement materials, including marginal and recycled materials (1). However, as the maintenance of thin unbound pavements is such an important issue in Australia, it was decided to conduct a pilot study to determine whether ALF could be used to assess the relative performance of a range of surface treatments and, further, if relative performance factors for performance parameters such as rutting and roughness could be derived which would assist in the development of network-based deterioration models, where the rate of deterioration of the various treatments could be related to an annualised level of average maintenance expenditure.

The pilot study was undertaken on a by-passed section of sealed granular pavement of the Hume Highway in Victoria, Australia, the major highway link between Melbourne and Sydney. The testing involved the trafficking of three different surface treatments at surface conditions varying from dry to continuously wet (2). The testing confirmed the technical feasibility of using accelerated pavement testing to quantify the influence of surface treatments on pavement deterioration. As a result, it was decided to conduct a more detailed study and also to conduct the testing indoors in order that environmental conditions could be more carefully controlled.

This paper describes this follow-up testing program and the use of the deterioration data to develop relative performance factors for rutting and roughness for a range of surface treatments and surface conditions. The research was funded by Austroads, the association of Australian state road agencies, and conducted by the ARRB Group.

ACCELERATED LOADING FACILITY

The ALF applies a half-axle, dual-wheel, or single-wheel load in one direction to a test pavement 12-m long at a speed of 20 km/h, which equates, under normal operating conditions, to about 50,000 load cycles each week. The magnitude of the load can be varied between 40 kN and 80 kN in 10 kN increments. The loading can be channelized or applied over a range of transverse distributions to better reflect field conditions. Since commencing operations in 1984, more than 30 million load cycles have been applied to about 150 test pavements. Current research is concentrating on the influence of heavy vehicles on the performance of both unbound granular and cemented pavements (3).

While the device is mobile, since 2000 ALF has been located at a permanent site in Melbourne, with most operations conducted inside a shed 54 m long and 18 m wide (see [Figure 1](#)) to assist in the control of the moisture environment. The shed is large enough to allow normal pavement construction equipment to operate inside it.

DETAILS OF TEST PROGRAM

Test Pavements

Details of the test sites, including surfacing type, surface integrity (cracked or uncracked)¹, environment (wet–dry), base type, base thickness and average deterioration rates are provided in



FIGURE 1 ALF operating indoors at a site in Melbourne.

Table 1. Figure 2 shows the cross-section of the test pavements. The purpose was to construct pavements having uniform strength and consistency in order that any differences in observed performance could be related to the surface treatment and test conditions. Figure 3 shows the layout of the test pavements inside the shed including details of the various surface treatments.

Testing Program

All the test pavements were subject to an initial 9,000 cycles of the 40-kN ALF load under dry surface conditions to bed down the surface stone of the seals. After this initial loading, the (dual wheel) loading was increased to 50 kN. All the initial and subsequent accelerated loading was applied using a pre-set (normal) transverse distribution across the test pavements to better simulate operating conditions.

Deterioration Monitoring

Vertical Deformation (Rutting)

The transverse surface profile along the 12-m test length of each pavement was measured at regular intervals at 0.5-m spacings using a transverse profilometer. The permanent surface deformation, or rutting, was defined as the net downward vertical movement from the unloaded transverse profile. This is the same definition for rutting that is used elsewhere for accelerated load testing (4). The rutting value reported for each level of loading for each test pavement was the mean of the deformation occurring in the left and right sides of the loading wheelpath over the 12-m test pavement length.

TABLE 1 Experiment Details and Results for 1999–2000 and 2000–2001

Parameter Exp	Experiment									
	1	2	3	4 4A	5	5A 6	6	7	8	
Surfacing type (mm)	single seal (14)	single seal (14)	single seal (14)	double seal (14/7)	double seal (14/7)	geotextile seal (14/7)	geotextile seal (14)	single seal (14)	single seal (14)	single seal (14)
Surface integrity	cracked ⁸	uncracked ⁹	uncracked	uncracked	uncracked	uncracked	uncracked	uncracked	uncracked	cracked
Surface environment	wet ¹	wet	dry ²	wet	wet	wet	wet	dry	wet	wet
Maintained	no	yes	yes	yes	yes	yes	yes	yes	yes	no
Base type and nominal thickness (mm)	crushed rock (150)	crushed rock (150)	crushed rock (150)	crushed rock (150)	crushed rock (150)	crushed rock (150)	crushed rock (150)	natural gravel (150)	natural gravel (150)	natural gravel (150)
Nominal strength (SNP) (9k cycles to final load)	4.2	4.1	4.6	3.8	3.7	4.5	4.0	4.6	4.2	4.7
SNP (standard deviation) ³	0.1	0.2	0.1	0.2	0.1	0.2	0.2	0.2	0.2	0.1
Rutting (mm) (9k cycles to final load)	16–44.9	15.6–38.4	10.6–21.6	11.8–66.5	15.3–77.7	11.2–22.3	7.80–36.0	9.00–32.1	15.3–53.1	15.5–65.4
Rutting rate (mm/MESA) ⁷	284	162	102	478	478	256	256	102	162	284
RDS–rut ⁴										
Range ⁵	0.1–0.3	0.3	0.2	0.4–0.7	0.3–0.5	0.2–0.3	0.2–0.4	0.3–0.4	0.1–0.4	0.1–0.3
Initial ⁶	0.3	0.3	0.2	0.4	0.3	0.2	0.2	0.4	0.2	0.2
Average	0.2	0.3	0.2	0.5	0.4	0.3	0.3	0.3	0.2	0.2
Roughness, IRI (9k cycles to final load)	6.43–6.49	2.77–8.23	3.09–4.96	2.59–9.63	4.60–19.28	1.69–6.11	1.28–5.83	1.06–4.75	2.44–10.06	1.88–15.20
Roughness rate (IRI–MESA) ⁷	56.8	30.4	23.4	257	257	125	125	23.4	30.4	56.8

¹ Continuously wet surface experiment.

² Continuously dry surface experiment.

³ Standard deviation of SNP along each test section.

⁴ Standard deviation of rut depth (RDS)–mean rut depth (rut).

⁵ RDS–rut estimated during the course of the experiment.

⁶ Initial RDS–rut after “bedding in.”

⁷ Deterioration rate is based on average value found for all experiments with the same surface treatment during gradual deterioration. MESA = millions of equivalent single axles.

⁸ Cracked only through the surface treatment, the base is uncracked.

⁹ Uncracked surface treatment and base.

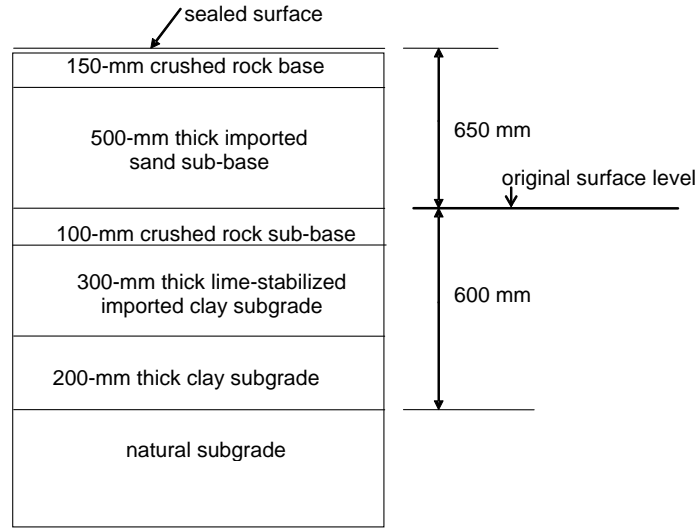

FIGURE 2 Cross-section of test pavements.

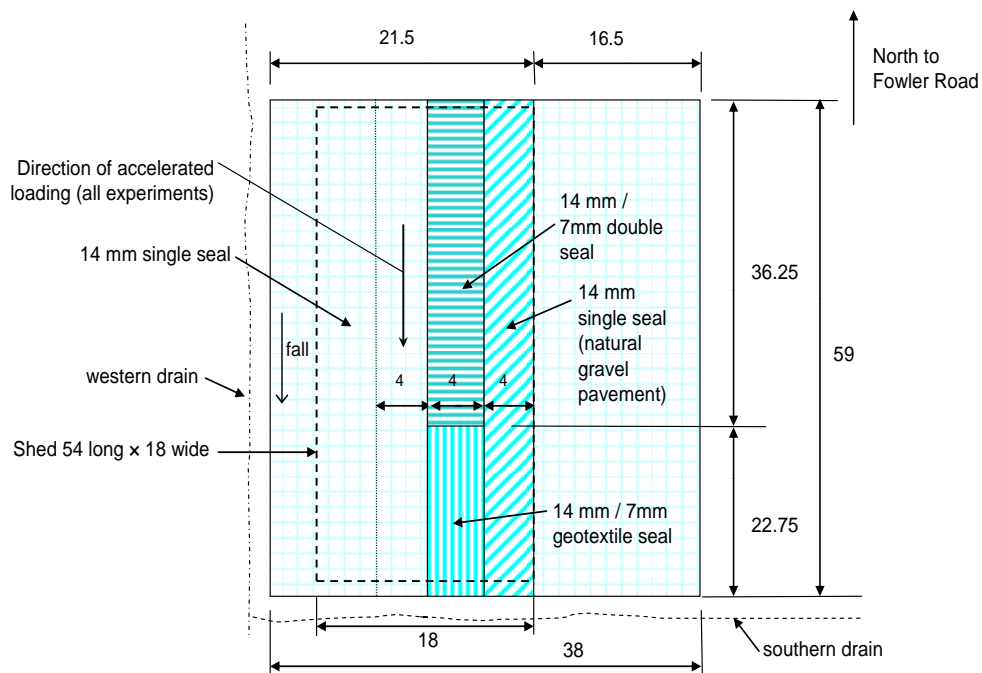

FIGURE 3 Layout of test pavements (all dimensions in meters).

Roughness Estimation

The longitudinal surface profile along each 12-m test pavement length was derived from the transverse profile data based on the mean of the deformation occurring in the left and right sides of the loading wheelpath for each 0.5-m interval along each test pavement.

The international roughness index (IRI, m/km) (5) was estimated from the longitudinal profile data. In estimating the IRI, each longitudinal profile assumed a 50-m flat surface ‘lead in’ and ‘lead out’ section at the beginning and end of each test pavement (6, 7). This resulted in IRI estimates based on a 112-m long longitudinal profile measured at 0.5-m intervals. These estimates of IRI were mean values made at given levels of load cycles and were in effect a relative estimate of roughness that was intended to represent roughness at given levels of loading for the various surface treatments on the test pavements.

Surface Deflection (Strength)

Vertical surface deflection was measured during trafficking at 1-m spacings along the centerline using the falling weight deflectometer (FWD). The deflection results were normalized to a test plate pressure of 700 kPa. Estimates of the test pavement–subgrade strength (SNP) (8) were derived from the FWD deflections using a relationship (9) defined below which provided consistent and realistic SNP values for a wide range of deflection results.

$$\text{SNP} = 12.992 - 4.167 \times \text{Log}_{10}(D_0) + 0.936 \times \text{Log}_{10}(D_{900}) + 3.51 \times \text{Log}_{10}[3.264 - 1.018 \times \text{Log}_{10}(D_{900})] - 0.85 \times (\text{Log}_{10}(3.264 - 1.018 \times \text{Log}_{10}(D_{900}))^2 - 1.43 \quad (1)$$

where

D_0 = FWD deflection at the center of the test plate normalized to a stress of 700 kPa and
 D_{900} = FWD deflection 900 mm from the center of the test plate normalized to a stress of 700 kPa.

RESULTS

Typical Observed Deterioration

A summary of the results of the testing is presented in Table 1. Included in the table is the nominal SNP of each test pavement, the standard deviation of the SNP, roughness, rutting, standard deviation of the rutting (RDS), and the ratio of the RDS to the mean vertical deformation, RDS–rut (10, 11). The RDS–rut data are presented as a means of displaying the variability of the measured rut data during each test. The value of RDS–rut was lowest for the tests conducted under dry surface conditions, while RDS–rut was highest for the tests where the SNP was low under wet surface conditions.

It can be seen in Table 1 that not all test pavements were constructed to the same pavement–subgrade strength. As is discussed later in this paper, this had an impact on the deterioration observed during testing, apart from the influence of different surface treatments on deterioration.

Observed Transition from Gradual to Rapid Deterioration

Figure 4 compares the mean rutting (mm) with the corresponding roughness (IRI) for all stages of all the ALF experiments (71 samples) during loading (see Table 1). The data for those tests

where the deterioration was gradual are presented separately from the tests where the deterioration was rapid. It can be seen from Figure 4 that two frontiers can be established for the transition from gradual to rapid deterioration where the rate of deterioration increased to two to three times the gradual deterioration rate. The extreme rutting (25 mm) and roughness (6.33 IRI) limits at the frontier for rapid deterioration shown in Figure 4 represents the most extreme levels of service limits used on sealed roads in Australia. The fact that these rutting and roughness limits were not dissimilar to those used in practice suggests that the ALF simulation of load testing was realistic from a physical viewpoint.

As deterioration beyond the transition from gradual to rapid deterioration is not the desired state for in-service pavements, the analysis of the various surface treatments described shortly was confined to the data observed during gradual deterioration.

Figure 5a compares the mean deformation (rutting) and loading cycles (converted to MESA) during gradual deterioration for cracked and uncracked single seals, the surfaces of which were continuously wet. Figure 5a also shows the linear deterioration relationships between rutting and load cycles for both the cracked and uncracked single seals. It can be seen that the relationships were different for the different surface treatments.

Figure 5b compares rutting and loading cycles under gradual deterioration for the double and geotextile seals under continuously wet conditions. Figure 5b also shows the linear deterioration relationships between rutting and load cycles. Once again, the relationships were different for the two surface treatments.

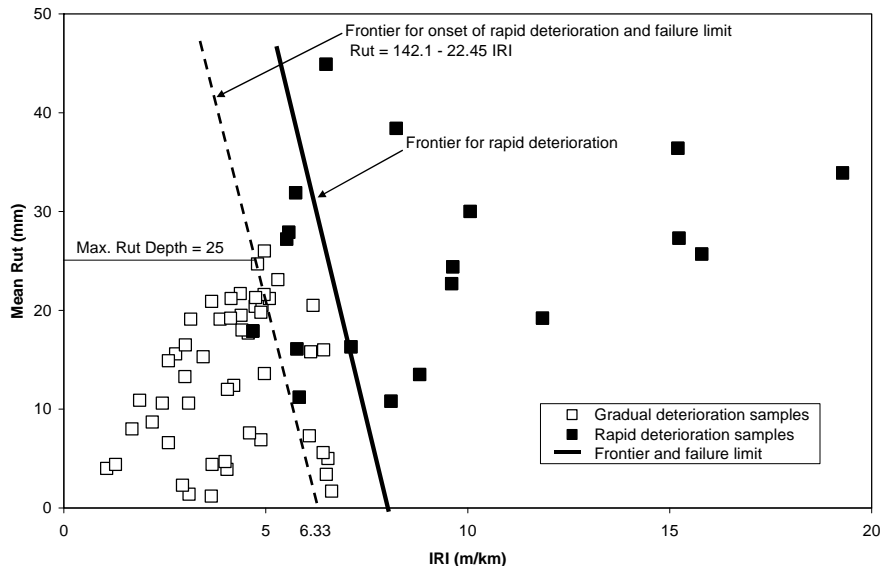
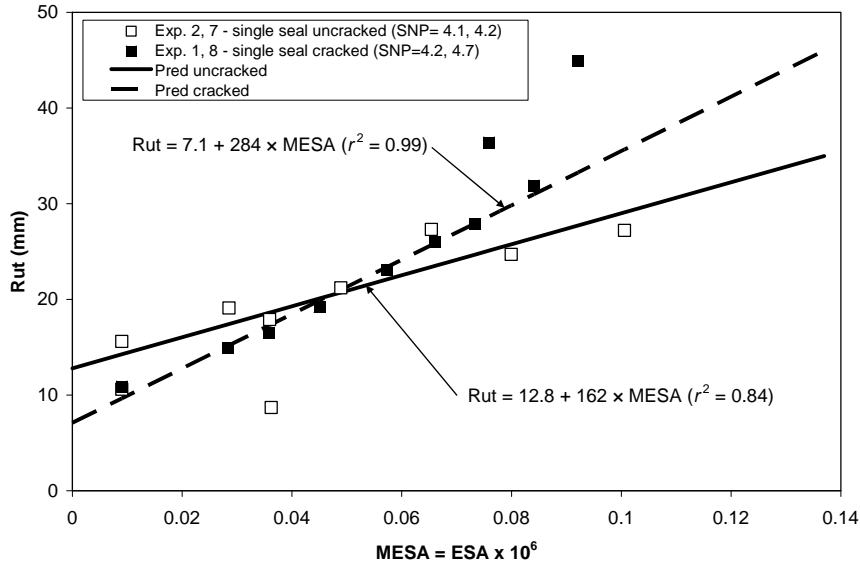
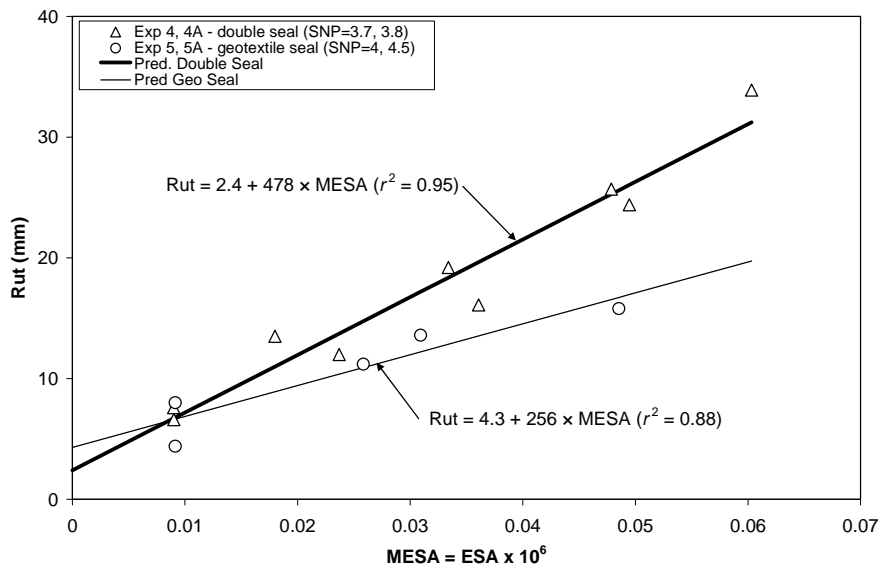

FIGURE 4 Mean rutting (mm) versus roughness (IRI) for all experiments.



(a)



(b)

FIGURE 5 (a) Rutting versus loading (MESA) for cracked and uncracked single seals and (b) rutting versus loading (MESA) for double and geotextile seals.

ANALYSIS OF DATA

Deformation Relationships for Experimental Deterioration

Linear regression was applied to the rutting and roughness data to develop statistically significant deterioration relationships for the gradual deterioration phase of all the experiments summarised in Table 1 and shown in Figure 4. As already discussed, typical relationships for

rutting are shown in Figures 5a and 5b. The general deterioration relationship for rutting before rapid deterioration commences is:

$$\text{Rut (mm)} = R_0 + \Delta\text{rut} \quad (2a)$$

Assuming that all relevant independent variables are in the following equation for gradual deterioration:

$$\Delta\text{rut (mm)} = \beta_1 \times \text{MESA} \quad (2b)$$

Then

$$\text{Rut (mm)} = R_0 + \beta_1 \times \text{MESA} \quad (2c)$$

Similarly, for roughness, the deterioration relationship before rapid deterioration commences is

$$\text{IRI (m/km)} = \text{IRI}_0 + \Delta\text{IRI} \quad (2d)$$

Again assuming that all relevant independent variables are in the following equation for gradual deterioration:

$$\Delta\text{IRI (m/km)} = \beta_2 \times \text{MESA} \quad (2e)$$

Then

$$\text{IRI (m/km)} = \text{IRI}_0 + \beta_2 \times \text{MESA} \quad (2f)$$

Equations 2c and 2f show that, for rutting and roughness respectively, the differences in surface treatment deterioration after the initial rutting and roughness, R_0 and IRI_0 , can be quantified by the different values of the regression coefficients, β_1 and β_2 , found for the applied loading, MESA.

where

- R_0 = rutting at zero loading cycles (MESA = 0), the constant from regression analysis;
- IRI_0 = roughness at zero loading cycles (MESA = 0), the constant from regression Analysis;
- Δrut = cumulative rut with loading cycles;
- ΔIRI = cumulative roughness with loading cycles;
- β_1, β_2 = regression coefficients for the independent variables;
- MESA = millions of equivalent standard axle (4th power) (ESA/10⁶ of all loading cycles) = $[(40/40)^4 \times 9000 + (50/40)^4 \times N] \times 10^6$; and
- N = number of loading cycles at 50 kN post 'bedding in' ('bedding in' involved 9,000 loading cycles at 40 kN).

The independent variable, MESA, was based on the number of load cycles, including those during ‘bedding in’, converted to equivalent single axles assuming the 4th power law². It should be noted that the above equations do not include an independent variable for SNP which could be expected to have some influence on the measured rutting. It would be expected that, provided all the test pavements were of a similar strength, then this variable would be unlikely to be significant in terms of the relative deformation of the various surface treatments. However, as shown in Table 1, this was not the case for Experiments 4 and 4A, where the pavement strength was lower than that of the other test pavements. Further refinement of Equations 2a to 2f was subsequently undertaken to account for the variation in test pavement strength and this is the subject of a future paper.

Relative Performance Factors (Rutting and Roughness)

The approach used to estimate the performance of one surface treatment i relative to a reference surface treatment j was to divide the statistically based deterioration relationship for one surface treatment by the deterioration relationship for the reference surface treatment. Typically the reference treatment j was a single uncracked seal under wet conditions which can be adjusted for climatic conditions (see Equations 5a, 5b, 7a and 7b) for specific sites.

The relative performance factor for maintenance effects, rpf_m , using the form of Equations 2b and 2e for cumulative rutting, Δrut , and cumulative roughness, ΔIRI , was calculated as follows.

For rutting:

$$rpf_{mrut} = \frac{\beta_1 \times \text{MESA (treatment } i)}{\beta_1^j \times \text{MESA (treatment } j)} \quad (3a)$$

which reduces to the following simple ratio:

$$rpf_{mrut} = \frac{\beta_1 \text{ (treatment } i)}{\beta_1^j \text{ (treatment } j)} \quad (3b)$$

Similarly, for roughness:

$$rpf_{miri} = \frac{\beta_2 \times \text{MESA (treatment } i)}{\beta_2^j \times \text{MESA (treatment } j)} \quad (3c)$$

which again reduces to the following simple ratio:

$$rpf_{miri} = \frac{\beta_2 \text{ (treatment } i)}{\beta_2^j \text{ (treatment } j)} \quad (3d)$$

The coefficients, β_1 , β_1^j , β_2 and β_2^j were determined using linear regression analyses of the rutting and roughness deterioration data for treatments i and j , respectively.

An example of this approach for the relative performance factor estimated for rutting of a cracked single seal relative to an uncracked single seal is as follows (Table 2). Figure 5a shows the results of the ALF experiments on the cracked single seals (Experiments 1 and 8) and the

TABLE 2 Summary of Maintenance Relative Performance Factors rpf_{mrut} and rpf_{miri} for Rutting and Roughness

Treatment	Exp. No.	SNP Range	Rutting $\beta_1 \times \text{MESA}$			Roughness $\beta_2 \times \text{MESA}$			Treatment Ratio	rpf_{mrut}	rpf_{miri}
			β_1	p value	r^2	β_2	p value	r^2			
ckdss ¹ (w)	8, 1	4.2–4.7	284	< 0.05	0.99	56.8	< 0.05	0.95	<u>ckdss (w)</u>	1.75	1.87
unckdss ² (w) ⁵	7, 2	4.1–4.2	162	< 0.05	0.84	30.4	< 0.05	0.83	unckdss (w)		
unckdgeo ³ (w)	5, 5A	4.0–4.5	256	< 0.05	0.88	125	< 0.05	0.82	<u>unckdgeo (w)</u>	0.54	0.49
unckdds ⁴ (w)	4, 4A	3.7–3.8	478	< 0.05	0.95	257	< 0.05	0.70	unckdds (w)		
unckdss (d) ⁶	3, 6	4.6	102	< 0.05	0.82	23.4	< 0.05	0.75	<u>unckdss (d)</u>	0.63	0.77
									unckdss (w)		

¹ ckdss = cracked single seal (100% cracked).

² unckdss = uncracked single seal.

³ unckdgeo = uncracked geotextile seal.

⁴ unckdds = uncracked double seal.

⁵ (w) = wet test.

⁶ (d) = dry test.

uncracked single seals (Experiments 2 and 7) under constantly wet conditions. Using Equation 3b, the relative performance factor for rutting, rpf_{mrut} , under wet conditions is

$$rpf_{mrut} = \frac{284 \text{ (cracked single seal)}}{162 \text{ (uncracked single seal)}} = 1.75$$

The relative performance factors derived for rutting, rpf_{mrut} , and roughness, rpf_{miri} , for a range of surface treatments are shown in Table 2. It was not possible to use the uncracked single seal surface treatment as the reference treatment for the double seal and geotextile surface treatments because, as already discussed, the pavement strength (SNP) of the double seal was much lower than that of the uncracked single seal. In this case the uncracked double seal under wet conditions was used as the reference treatment for the geotextile seal under wet conditions, even though the pavement strength of the double seal was also lower than that of the geotextile seal. As noted above, the use of refined deterioration relationships which incorporate pavement strength as an independent variable will be used in the future to improve the consistency and robustness of the relative performance factors to overcome this limitation in the experimental data.

Influence of Climate on Relative Performance Factors (Rutting and Roughness)

Uncracked Single Seals

Using the data in Table 2, the relative performance factors for rutting and roughness for an uncracked single seal under dry conditions [unckdss (d)], relative to an uncracked single seal under wet conditions [unckdss (w)], are:

$$rpf_{mrut} \frac{\text{unckdss (d)}}{\text{unckdss (w)}} = 0.63$$

$$rpf_{miri} \frac{\text{unckdss (d)}}{\text{unckdss (w)}} = 0.77$$

Relative to dry conditions, the factors are inverted as follows:

$$rpf_{mrut} \frac{\text{unckdss (w)}}{\text{unckdss (d)}} = \frac{1}{0.63} = 1.59 \quad (4a)$$

$$rpf_{miri} \frac{\text{unckdss (w)}}{\text{unckdss (d)}} = \frac{1}{0.77} = 1.30 \quad (4b)$$

Assuming that an uncracked single seal tested under dry conditions would have relative performance factors for rutting and roughness of unity (1.0) then the results suggests that there was a variation in the relative performance factors for a given treatment due to climatic effects. Consequently, in order to derive a relationship for the variation of the relative performance factors for an uncracked single seal with the change in climate from dry to wet, the following assumptions were made.

- There was a linear variation in the relative performance factors from a dry to a wet climate.
- The dry test condition approximated to a Thornthwaite Moisture Index (I), I , value of -50 (lowest value).
- The constantly wet test condition approximated to a Thornthwaite Moisture Index value of $+100$ (nominally highest value).

Using these assumptions, Figure 6 shows the variation of the relative performance factors for an uncracked single seal with Thornthwaite Moisture Index for rutting and roughness respectively. Also shown in the figure are the following linear relationships for the rutting and roughness rpf values that meet the boundary conditions set by Equations 4a and 4b:

$$rpf_{\text{rut}} \text{ unckdss } (I/d) = 1.197 + 0.00393 \times I \quad (5a)$$

$$rpf_{\text{iri}} \text{ unckdss } (I/d) = 1.100 + 0.002 \times I \quad (5b)$$

where

$rpf_{\text{rut}} \text{ unckdss } (I/d) =$ relative performance factor for rutting at current condition, I , relative to the dry condition

$rpf_{\text{iri}} \text{ unckdss } (I/d) =$ relative performance factor for roughness at current condition, I , relative to the dry condition

$I =$ Thornthwaite Moisture Index (a general index for climatic conditions) for current pavement conditions.

The results in Figure 6 suggest that the variation in the relative performance factors with climate is significant for rutting of the uncracked single seals.

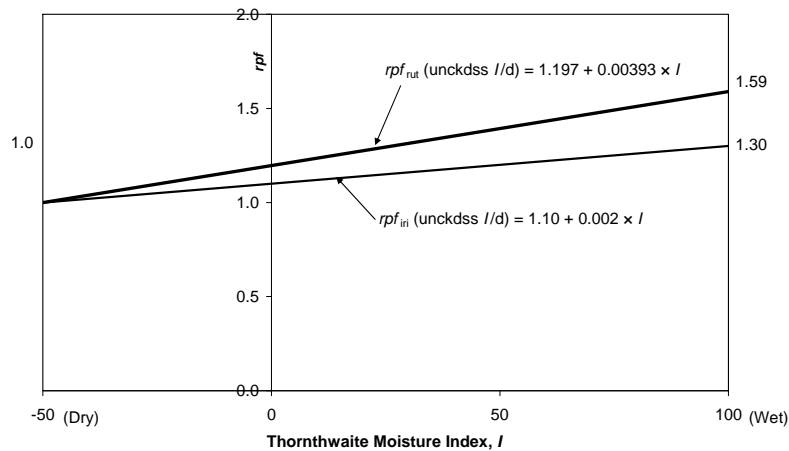

FIGURE 6 Variation in $rpf_{\text{rut}} (I/d)$ and $rpf_{\text{iri}} (I/d)$ with Thornthwaite Moisture Index (uncracked single seals).

Cracked Single Seals

Using the data in Table 2, the relative performance factors, rpf_{mrut} and rpf_{miri} , for rutting and roughness, respectively, for a cracked single seal under wet conditions [ckdss (w)] relative to an uncracked single seal under wet conditions [unckdss (w)] are as follows:

$$rpf_{\text{mrut}} \quad \frac{\text{ckdss (w)}}{\text{unckdss (w)}} = 1.75$$

$$rpf_{\text{miri}} \quad \frac{\text{ckdss (w)}}{\text{unckdss (w)}} = 1.87$$

Assuming that cracking has no impact on performance under dry conditions, it would be expected that the rpf values for rutting and roughness of a cracked seal relative to an uncracked single seal would be unity (1.0). On that basis, Equations 4a and 4b can be used to convert the above equations to the following:

$$rpf_{\text{mrut}} \quad \frac{\text{ckdss (w)}}{\text{unckdss (d)}} = 1.75 \times \frac{\text{unckdss (w)}}{\text{unckdss (d)}} (= 1.59) = 2.78 \quad (6a)$$

$$rpf_{\text{miri}} \quad \frac{\text{ckdss (w)}}{\text{unckdss (d)}} = 1.87 \times \frac{\text{unckdss (w)}}{\text{unckdss (d)}} (= 1.30) = 2.43 \quad (6b)$$

Figure 7 shows the variation of the rpf values for a cracked single seal relative to an uncracked single seal with Thornthwaite Moisture Index for rutting and roughness, respectively. Also shown in the figure are the following linear relationships for the rutting and roughness rpf values that meet the boundary conditions set by Equations 6a and 6b:

$$rpf_{\text{mrut}} \quad \frac{\text{ckdss (I/d)}}{\text{unckdss}} = 1.59 + 0.0119 \times I \quad (7a)$$

$$rpf_{\text{miri}} \quad \frac{\text{ckdss (I/d)}}{\text{unckdss}} = 1.477 + 0.00953 \times I \quad (7b)$$

It can be seen in Figure 7 that, as expected, the variation in the relative performance factors for rutting and roughness of cracked single seals relative to uncracked single seals was far more significant for the cracked single seals compared to the uncracked single seals.

Uncracked Geotextile and Double Seals

The relative performance factors for rutting and roughness for the uncracked geotextile and double seals were assumed not to vary with climate relative to an uncracked single seal. This assumption was made on the basis that the performance of double seals is less likely to be influenced by climatic effects because their greater binder thickness results in improved imperviousness to water.

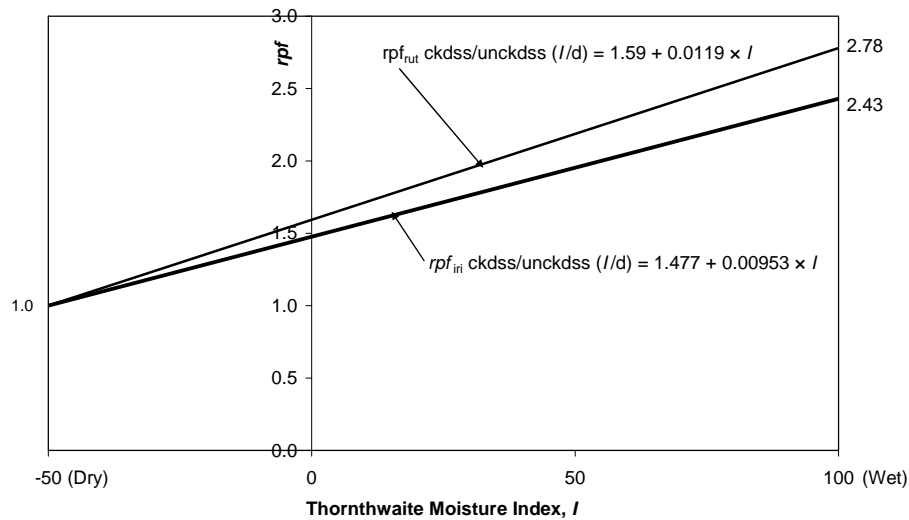

FIGURE 7 Variation in $rpf_{rut} (I/d)$ and $rpf_{iri} (I/d)$ with Thornthwaite Moisture Index (cracked single seals relative to uncracked single seals).

Relative Performance Factors (Pavement Strength)

No relative performance factors were estimated for the deterioration of pavement strength, as assessed by the FWD deflections, with the various surface treatments because, for most treatments, statistically significant relationships could not be derived from the ALF data related to the loss of strength during loading. Even the cracked pavements subject to a continuously wet surface were not observed to lose strength significantly as loading continued. This outcome suggests that pavement strength loss under accelerated loading is not well simulated as strength loss is a long-term phenomenon.

DISCUSSION OF RESULTS

The results in Table 2 for the relative performance factors for rutting and roughness show the expected relativities between the various surface treatments for the various surface conditions. As already discussed, because of the significantly lower strength of the double-seal surface treatment test pavements, it was not possible to use the same reference surface treatment of an uncracked single seal under wet conditions [unckdss(w)] for the geotextile and double-seal surface treatments. As a result the relativities between these two particular surface treatments are probably overstated in Table 2. However, as noted, accounting for this variation in test pavement strength is the subject of current research and it is expected that the relative performance factors for all the surface treatments will then be able to be based on the same reference surface treatment.

The deterioration of pavement strength is not well simulated under accelerated loading probably because strength deterioration is a long-term process. This experimental work raises the question, are the relativities in surface distress (rutting and roughness) deterioration found with

the various surface treatments reliable? On the basis that the full-scale accelerated loading simulation appears to be physically appropriate for the measured surface distresses, and that the relativities found for the surface treatments also appear to be of the appropriate order under the climatic variations used, then the experimental outcomes are likely to be acceptable. However, this needs to be validated by comparing the measured on-site deterioration with the predicted deterioration estimated by applying the relative performance factors to the observed rates of surface deterioration.

Although only thin bituminous surface treatments were used in the experimental testing, it would seem reasonable to expect that this form of testing could be extrapolated to thin asphalt surface treatments (say ≤ 50 mm) over flexible pavement bases. Again this would need to be confirmed by comparing the measured on-site deterioration with the predicted deterioration estimated by applying the relative performance factors to the observed rates of surface deterioration.

CONCLUSIONS

This paper describes an accelerated pavement testing program which had, as its primary aim, the development of relative performance factors for a range of typical surface maintenance treatments used to manage Australia's sealed granular road network. Factors were successfully derived for rutting and roughness deterioration, but could not be derived for pavement strength deterioration. At this stage these experimentally based estimates appear reasonably reliable. They will be improved with further refinement, but confirmation of these estimates is needed with validation by on-site measurements of deterioration.

The relative performance factors derived for rutting and roughness on single uncracked and cracked seals were refined to account for the influence of climatic effects (surface water). On the basis that double seals and geotextile seals were not susceptible to the influence of surface water to the same extent as single seals, no refinement of the relative performance factors for climatic effects for these surface treatments was undertaken. Further refinement of the relative performance factors derived from the experimental data is planned so that the impact of the variation of the pavement strength is accounted for. This will improve the reliability of these factors.

The relative performance factors can be applied to observed rates of rutting and roughness deterioration for a reference surface treatment to predict the deterioration of other surface treatments, provided there is no change to the prevailing traffic loading and climatic conditions. To this end, a number of reference observation pavement segments are available in Australia as a result of the long-term pavement performance and long-term pavement performance maintenance programs. Deterioration (rutting, roughness, cracking and strength) has been monitored for up to 11 years on some segments and monitoring is continuing.

The use of these factors will assist in the evaluation of the relative performance of various surface treatments in life-cycle cost analyses. The relative performance factors for rutting and roughness deterioration can also be used to develop network-based RD models, where the rate of deterioration of the various treatments can be related to an annualized level of average maintenance expenditure.

The accelerated load testing experiments appear to be a rapid means of determining the relative performance of various surface treatments applied to flexible pavement bases. It would

be useful to compare the outcomes from this approach, and the resources involved, with those from a theoretical nonlinear finite element analysis based on laboratory material performance characterisation. So far the accelerated load testing approach appears to account for variations in climatic conditions and loading, although some necessary assumptions are required to take account of on-site conditions.

AUTHORS' NOTES

1. Cracked surfaces were fabricated by saw cutting through the surface treatment at 0.5 to 1.0 m centers transverse to the longitudinal loading direction and maintained open by clean aggregate. Uncracked surfaces were fully intact surface treatments. In all cases the pavement base was uncracked.
2. Recent work conducted using ALF has demonstrated the applicability of the fourth power law to Australasian granular materials (3).

REFERENCES

1. Sharp, K. G. Full Scale Accelerated Pavement Testing: a Southern Hemisphere and Asian Perspective. *Proc., 2nd International Conference on Accelerated Pavement Testing*, Minneapolis, Minn., 2004.
2. Martin, T. C., and B. P. Gleeson. *The Effect of Maintenance on Pavement Performance: The Accelerated Load Pilot Test*. ARRB Transport Research Contract Report RC 7094B, 1999.
3. Yeo, R. E. Y., and K. G. Sharp. Influence of Vertical Load and Tyre Type on the Performance of Unbound Granular Pavements. *Proc., 22nd ARRB Conference*, Canberra, Australia, November 2006.
4. Maree, J., C. Freeme, N. Van Zyl, and P. Savage. The Permanent Deformation of Pavements with Untreated Crushed-Stone Bases as Measured in Heavy Vehicle Simulator Tests. *Proc., 2nd ARRB Conference*, Vol. 2, No. 2, 1982, pp. 16–28.
5. Sayers, M., T. Gillespie, and C. Queiroz. *The International Road Roughness Experiment*. World Bank Technical Paper No. 45, 1986, pp. 365–368.
6. *Roadrurf: Software for Analyzing Road Profile*. University of Michigan Transport Research Institute, Ann Arbor, 1997.
7. Prem, H. Personal Communication: Estimating IRI from Experimental Accelerated Load Test Section. ARRB Transport Research, May 1999.
8. *HDM4 Technical User Guide (Draft)*. International Study of Highway Development Management Tools, University of Birmingham, U.K., June 1997.
9. Roberts, J. A Pavement Structural Deterioration Model for HDM-4. *Proc., First European Pavement Management Systems Conference*, Budapest, 2000.
10. Martin, T. C., B. P. Gleeson, J. R. Johnson-Clarke, P. F. Tredrea, and D. W. Fossey. *The Effect of Maintenance on Pavement Performance: The Accelerated Load Testing in 1999/2000*. ARRB Transport Research Contract Report, RC90264, 2000.
11. Martin, T. C., B. P. Gleeson, J. R. Johnson-Clarke, P. F. Tredrea, R. Luke, and D. W. Fossey. *The Effect of Maintenance on Pavement Performance: Accelerated Load Testing in 2000/2001*. ARRB Transport Research Contract Report RC1739, 2001.
12. Thornthwaite, C. W. An Approach Toward a Rational Classification of Climate. *Geographical Review*, Vol. 38, No. 55, 1948.

Use and Application of Accelerated Pavement Testing in Pavement Preservation Research

W. STEYN

CSIR Built Environment

This paper focuses on the use and application of Accelerated Pavement Testing (APT) for the evaluation of pavement preservation actions. It is based on work done over a number of years and does not focus on the specific performance of any one preservation option but rather on the aspects of APT that can be used to provide improved insights into the performance–behavior of such actions on existing pavement structures. In this regard it investigates the types of pavement preservation that can be evaluated using APT, different types of available APT, and vital pavement parameters to be monitored during such testing and suggests a protocol for the planning and execution of APT of pavement preservation actions. The main conclusion from the paper is that pavement preservation treatments can be evaluated using APT machines. Specific aspects that require careful attention during the process are the preparation of the test section (replication of failure mechanism to be rectified), monitoring of pavement response for all potential failure mechanisms, and that the analysis of the outcomes are performed with a view of incorporating information obtained from in-service pavements and laboratory test outputs.

Pavement preservation pertains to all of the actions taken to ensure that a pavement remains in a serviceable condition for the structural life of the pavement. Such actions may include the addition of sprayed-on layers to the existing surfacing, addition of various types of seals to the existing surfacing or the addition of a thin asphalt overlay onto the existing surfacing. All of these actions can also be combined with other actions such as crack sealing and pothole filling. In some cases the existing surfacing and parts of the base layer may be removed and replaced as part of these actions. In all cases, the objective of the operation is to provide a pavement with an acceptable level of functional and structural life for an extended period of time.

Accelerated pavement testing (APT) is defined as the use of accelerated traffic loading on a section of pavement with the purpose of simulating the effects of long-term traffic on the pavement structure in a relatively short period. This action enables engineers to evaluate the expected performance and behavior of a specific pavement structure (or components thereof) in a relatively short period. Ultimately, the objective is to ensure that more cost-effective decisions can be made regarding the design, construction, and maintenance–preservation of pavement structures.

This paper focuses on the application of APT for the evaluation of pavement preservation actions. It is based on work done over a number of years, and does not focus on the specific performance of any one preservation option, but rather on the aspects of APT that can be used to provide improved insights into the performance–behavior of such actions on existing pavement structures. In this regard it investigates the types of pavement preservation that can be evaluated using APT, different types of available APT, vital pavement parameters to be monitored during such testing and suggests a protocol for APT testing of pavement preservation actions. Reference is made to APT programs in South Africa where the focus was on pavement preservation actions to illustrate some concepts.

PAVEMENT PRESERVATION

Pavement preservation can be achieved through various options. The objective of pavement preservation is to extend the life of an existing pavement, typically through rectifying the problems that present as either structural or functional distress on the existing pavement. Depending on the causes of distress, the specific options for pavement preservation would be selected. In Table 1 a summary of typical distress mechanisms is provided together with potential preservation actions for each of these mechanisms. Often a number of mechanisms may affect a specific pavement, and in such cases a combination of preservation measures may be combined to obtain an optimal solution to the specific problem.

When selecting appropriate pavement preservation options to rectify problems on an existing pavement, it is important to select the options in a scientific way. This requires a full investigation and clear understanding of the most probable causes of the initial deterioration and the subsequent design of a preservation option that specifically addresses these causes and does not introduce new distress mechanisms in the pavement structure. In this regard it is important to note that preservation options cannot be selected as standard options from a menu, as the specific causes for deterioration–failure of the pavement structure must be clearly defined to ensure that any preservation action does not constitute only a short-term bandage solution that merely cures the symptoms not the causes of the problem. It is also important to realize that a specific pavement may present different types of deterioration over its length, i.e., due to changing traffic loads or geographical features (i.e., a pavement running through cuts and over fills). In these circumstances it would be important to design the preservation options such that the specific distress modes are addressed where they occur.

When designing preservation options for a specific pavement structure, it is also important to evaluate aspects such as the expected remaining life of the individual components of the pavement structure as well as failures that may develop as a result of the specific preservation option. This may entail an analysis of the sublayers of the pavement structure to determine whether they can withstand the traffic loading after preservation for the same duration as the new surfacing–base layers. It also entails investigation into aspects such as the potential reflection of cracks from the existing layers through a new asphalt concrete (AC) overlay, and the effect of these failure modes on the ultimate effectiveness of the selected preservation option.

TABLE 1 Typical Pavement Distress Mechanisms and Potential Preservation Options to Rectify These Problems

Distress Mechanism	Potential Preservation Measure
Surface cracking	Crack sealing, application of a reseal–new AC surface
Surface rutting	Milling and replacement, addition of a thin asphalt overlay
Base failure	Reworking and stabilization through deep in situ recycling, replacement of material with improved quality base and surfacing
Loss of functional properties (skid resistance, riding quality, etc.)	Resurfacing using a seal, replacement of the AC through an overlay

ACCELERATED PAVEMENT TESTING

Types of APT

Various types of APT exist internationally. The available systems can be divided into full-scale systems and small-scale systems. Full-scale APT systems are those where a standard truck tire (or combination of tires) is used for applying the loads to the pavement [e.g., the heavy vehicle simulator (HVS)], while small-scale systems are those where a scaled-down version of a truck tire and tire load is applied to the pavement [e.g., the model mobile load Simulator (MMLS)]. Full-scale APT can again be divided into circular and linear tracking devices (1,2). The objective of APT is to apply traffic loads and sometimes also environmental effects to a pavement (or a section of pavement) at an accelerated rate compared with normal loading, and to determine the reaction of the pavement and its constitutive layers to this loading in a shorter time than would normally occur on a pavement under typical traffic and environmental conditions. Acceleration of traffic loading is attained through the repeated loading by a set of truck tires over a short section of pavement, most often at increased loads. These increased load levels (through the application of the well-known power damage laws) cause the number of traffic loads applied to the pavement to be multiplied by a factor of typically between 1 and 40. Through this process the response (mostly structural) of the pavement can be quantified during a much shorter time than would be the case if a normal road was monitored under standard load applications.

Benefits of APT in Pavement Preservation Evaluation

The process of APT provides various benefits to pavement evaluation, specifically when assessing the effectiveness of pavement preservation techniques. The benefits of using APT for this purpose can be summarized as follows:

- Much quicker evaluation of the response from a selected preservation treatment (mostly structural response);
- The potential to compare a number of possible treatments with each other under similar conditions (3–5,7);
- The potential to simulate the effects of the environment (typically heat–cold and wet–dry) on the response of the preservation treatment (1,2,6,7,11)
- Specific pavement failure mechanisms can be caused on a test section before applying preservation techniques and the effect of various preservation options on these specific failure conditions evaluated (1–4,6,10);
- The effect of different loading parameters (i.e., load level or tire inflation pressure–tire contact stresses) on the response from the various pavement parameters can be obtained (1–5,7,11);
- A potential suite of preservation options can be applied to a similar ‘failed’ pavement and the responses from each of these evaluated and directly compared with each other in a relatively short space of time (1–6).

Limitations of APT in Pavement Preservation Evaluation

There are, however, certain limitations to the use of APT in evaluating pavement preservation techniques too. These include the following:

- The effect of riding quality can not be quantified accurately due to the relatively short pavement sections evaluated and the load application method utilized on some devices (controlled constant load levels);
- The loading speed of most APT devices is lower than conventional traffic and higher speed effects (i.e., whipping of aggregate from a new surfacing due to high speeds) can thus not be simulated correctly;
- The test sections are often short and the effects of constructing such short preservation options can lead to undesirable construction deficiencies; and
- The effect of cornering, acceleration, and deceleration cannot be tested.

However, the benefits of APT in evaluating specific aspects of pavement preservation option performance still outweigh the limitations in the broader sense. As long as the focus of the investigation is on those aspects that can be evaluated accurately and due cognizance is taken of those aspects that cannot be evaluated accurately, the potential benefit of conducting the APT evaluation can be significant. It is also important to acknowledge the broader improvement in understanding of the behavior and performance of the pavement as a structure when performing the APT, something that may be amiss when evaluating the preservation options on their own without the support of an existing pavement structure. It also remains important to conduct the required field and laboratory evaluations of the potential preservation option together with the APT.

ESSENTIAL PARAMETERS TO MONITOR

Failure Mechanisms

There are a number of essential pavement response parameters to monitor when evaluating the effect of pavement preservation treatments on existing failed pavement structures. These parameters depend on the failure mechanism that needs to be rectified on the pavement. In [Table 2](#) a summary of typical original (before preservation treatment) failure mechanisms is given with a list of the most important parameters to monitor for each of these conditions. It is important during the planning of the APT to ensure that the instrumentation and monitoring plan do provide for the evaluation of all the failure mechanisms that are expected to occur during the test. A thorough understanding of pavement engineering is required to plan and execute the APT.

Role and Analysis of Supporting Pavement

The condition of the supporting layers in the pavement when evaluating the performance of a pavement preservation treatment is very important. Different support conditions may lead to different failure mechanisms for the preservation treatment, and it is vital that the support

TABLE 2 Typical Failure Mechanisms and the Vital Pavement Response Parameters to Monitor During APT

Failure Mechanism	Vital Pavement Response Parameters
Surface cracking	Crack activity, crack length, crack reflection, pavement deflection
Surface rutting	Rut depth, extent, location (surface and in-depth), supporting layer condition (density, bearing capacity, strength), pavement deflection
Base failure	Deflection (surface and in-depth), rut depth and extent, density, bearing capacity
Loss of functional properties (skid resistance, etc.)	Surface texture, occurrence of bleeding

conditions be consistent over the length of the test section, between different test sections with alternative treatments, and similar to the support conditions expected in the field. The mechanism in which the support conditions will potentially influence the performance of the preservation treatment should also be considered before initiation of the experiment, as this may influence the specific failure conditions during the test. In order to create the correct conditions for the preservation treatments to be evaluated, there are various methods to prepare the required support conditions. These include the following:

- Crack and seat of existing pavement (3,4);
- Design and construction of specific support conditions (10,11);
- Selection of test sections from an existing failed network (5–7);
- APT on intact sections until a certain failure mechanism has occurred (11,12).

The specific method used for preparing a support structure for APT will differ depending on the type of support structure that need to be evaluated. For APT, the support structure may either consist of an existing failed traffic lane where the preservation treatment are added to this traffic lane before the APT machine is moved on to the section, or the construction of a dedicated test section where the specific failure conditions are caused using either preliminary overloading using the APT machine or by distressing the pavement using rollers (3,4). It is important to develop a monitoring method that ensures that the pavement is similar to the condition when the preservation treatment will typically be added in the field. Different methods that can be employed to perform this task include:

- In situ dynamic cone penetrometer tests to determine the bearing strength and pavement balance information (3,4);
- Deflection testing of the pavement structure (3,4,6,11,12);
- Crack activity monitoring (5);
- Surface rut measurements (3,4,7,10,12); and
- Other pavement condition evaluations (i.e., seismic stiffness, densities).

Measurement and Quantification of Failure

Finally, the response of the pavement preservation treatment must be monitored during the APT test to determine the expected additional life from the treated pavement. In this case it is important to ensure that not only the original failure mechanism parameters are monitored and quantified, but that all of the typical pavement response parameters are included in the monitoring program, as it may happen that the failure mechanism of the original pavement structure differs from the failure mechanism of the treated pavement structure. This may specifically be the case if the original failure mechanism was due to a surfacing or base layer that was replaced during the preservation treatment, and through this process another part of the pavement structure becomes the weakest part of the pavement. Focus should thus be on both the expected failure mechanisms (i.e., reflective cracking through an asphalt overlay) as well as unexpected failure mechanisms. An APT experiment should thus always be designed with the detailed objectives foremost, but also incorporating general pavement response parameters.

TYPICAL PAVEMENT PRESERVATION APT APPLICATIONS

In order to provide examples of typical pavement preservation treatment evaluations using APT, a selection of projects where the HVS ([Figure 1](#)) specifically was used in South Africa are provided below. The focus is not on the detail of each of these projects, but merely a summary of the conditions evaluated and the typical outcomes of the evaluation. A host of other examples can also be found in the literature on APT (*1,2,13,14*). Based on this information the protocol for pavement preservation APT presented in the next section has been developed.

HVS testing has been used to evaluate preservation techniques for the following types of failed pavement structures:

- Cracked surfacings (*3,5*),
- Failed base layers (*7*), and
- Potholes (*10*).

In this process the following types of pavement preservation treatments have been evaluated:

- Surface seals (*3,4,8,9*). This research indicated that surfacing seals can be used effectively in pavement preservation, especially when adequate support is provided in the pavement structure. The successful use of marginal aggregates in surfacing seals under certain loading conditions has also been proven;
- Thin AC overlays (*3–5,7,15*). In this research the performance of thin AC overlays over various types of base layers as evaluated. It was shown that these overlays perform well over lightly cement stabilized base layers. Tolerance limits for accommodation of crack activity (originating from a cracked concrete pavement overlaid using AC) were developed, and it was shown that bitumen rubber AC could withstand crack movements of at least double the magnitude of those withstood by a normal AC overlay. The use of thinner layers of polymer



FIGURE 1 HVS located on a test site.

modified AC overlays has been shown through HVS testing to provide similar performance to thicker conventional AC overlays.

- Granular base layers combined with surfacing seals (3,4). In this project a new granular base layer was used together with a surfacing seal as a rehabilitation option over an existing failed lightly cemented base layer. It was shown that this option was more economical for pavements with between 10 and 30 million equivalent single-axle loads than a thin (50 mm) AC overlay or a double seal directly applied to the failed base layer.

- Thin concrete overlays (11). This research has so far indicated the similarities in failure mechanisms shown by HVS testing and detailed finite element modeling of the pavement structure. Concrete thickness and the presence of joints and/or cracks was indicated through both finite element model and HVS testing as being critical to the performance of the ultra-thin continuously reinforced concrete sections;

- Cold mix pothole fillers (10) This work evaluated the performance of a specific cold mix pothole filler under APT conditions. The effects of pothole dimensions, shape, dry and wet conditions and various load levels were evaluated.

- Comparison between various rehabilitation options (3,4,5). The work, focusing on different rehabilitation options for cemented sections, has shown that the design class of the road affects the optimum rehabilitation option, with lower design classes favoring a double seal rehabilitation option while higher design classes favored a graded crushed stone base and thin asphalt overlay option.

PROTOCOL FOR PAVEMENT PRESERVATION APT

Based on the information available in literature and the summarized discussion in this paper of some of these aspects, the following protocol for pavement preservation APT is suggested. The objective of this protocol is mainly to serve as a guide to practitioners and researchers to plan APT experiments on pavement preservation in such a way that vital information is not overlooked during the experiment, and that the information from an experiment can also serve a wider purpose than only a specific project developed objective. Although many aspects covered are applicable to APT planning in general, specific aspects of importance when evaluating pavement preservation applications are highlighted.

Planning

A clear understanding should be developed during the planning phase of the existing failure mechanisms to be rectified by the preservation treatment, the expected failure mechanisms of the treated pavement and the mechanism in which the preservation option is planned to rectify the existing problems on the pavement. The effect of parameters such as the supporting conditions should be evaluated before the test starts, to ensure that all those externalities to the preservation treatment that may influence its behavior are controlled during the test. These include both loading and environmental conditions used during the APT.

Parameters

All parameters that may provide information on the performance–behavior of the pavement structure and the constituent layers and materials in the pavement structure should be identified during the planning phase, their expected behavior during the test determined and a specific monitoring program to evaluate their behavior during the test planned. This includes those parameters that may not initially appear to be important in the behavior of the pavement, but that may later provide important information on aspects of the ultimate failure condition observed (e.g. specific construction problems or delays that may have affected the curing of a stabilized layer, or early opening of the road to traffic that may have affected the pavement layer strength development). It is again vital to view the pavement as a structure and not the preservation treatment as a stand-alone entity during the testing and analysis.

Testing Program

The testing program for the APT evaluation should be clear in the objectives to ensure that the selected testing conditions are in line with the real operating conditions of the pavement as well as the research questions to be answered through the APT. In this regard it is important not to overload the pavement structure to such an extent that failure mechanisms that would not occur under real traffic may develop (i.e., crushing of material through overstressing beyond the reasonable stresses expected in the pavement). Further, the environmental conditions for the test should be selected in such a way that the expected field conditions will be simulated and that critical conditions form part of the evaluation. Thus, wet tests may be applicable in some conditions while elevated temperature tests may be more applicable in other conditions, depending on either the environment where the treatment is due to be used or the material type. It

is also important in the planning to ensure that specific environmental conditions be applied at the optimum time for them to affect the pavement behavior (i.e., heat on fresh asphalt and cold conditions on old asphalt). When changing test parameters between tests it is also important to ensure that only one parameter is changed at a time, otherwise the effect of a combination of changes will be hidden in the combined change in response of the pavement structure, and it may obscure important behavior patterns that may influence decisions regarding the applicability of the specific pavement preservation treatment.

Data Collection

The data-collection program should be planned to ensure that the majority of the data is collected during times of expected changes in the behavior of the pavement structure. Broadly similar data collection programs should be adhered to through a suite of tests when comparing different treatment options, to ensure fair comparisons between different tests. Parameters that may play a secondary role in the behavior of the pavement may be observed at lower frequencies than the primary parameters, but should not be ignored, as information collected from these parameters may explain the behavior of the primary parameters.

Data Analysis

Data analysis should be conducted according to a pre-planned schedule to ensure that it is performed as soon after data collection as possible, and that the analysis focuses on the expected changes in behavior as defined during the planning of the test. This should ensure that any changes in parameters are observed soon after they occurred, and that decisions regarding possible changes in the APT programme can be made at optimum times. Again, such changes should only be made after careful consideration, as the loading conditions for the different treatment options should be similar in order to realistically compare their effectiveness.

Application

The application of the results of the APT should be planned with a view to the wider behavior of the pavement as a whole and not only focusing on the specific preservation options. In this regard the influence of specific support and environmental conditions on the preservation treatments should always be catered for in the analysis of the results to ensure that the results under specific conditions are not blindly applied in areas where the externalities differ to such an extent from the original experiment that it may cause the preservation treatment to behave differently under the APT evaluation.

CONCLUSIONS

Based on the information and discussions presented in this paper, the following conclusions are drawn:

- Pavement preservation options can be evaluated using APT if the evaluation program is well planned and executed with a view to observing the pavement as a whole and the specific response of the preservation option as part of a pavement structure response to external loads.
- Different types of failure conditions can be simulated during APT to ensure that the preservation treatment can be exposed to similar conditions to those expected in the field.
- The planning and execution of the APT should incorporate all important parameters, including those aspects that may not at first glance appear important for the specific failure mechanism–treatment option, to ensure that the ultimate response of the treatment to external loads can be well defined from the observed results of the APT.
- APT on pavement preservation options should be viewed as part of the broader skills development and information gathering drive of a roads agency, as vital information about the general performance and behavior of pavements and their constituent layers can be derived from a well planned APT program. Such information will be useful in the broader pavement engineering field.

RECOMMENDATIONS

Based on the information and discussions presented in this paper, the following recommendations are made:

- APT should be used for the evaluation of pavement preservation options, after ensuring that the tests are well planned with a broad understanding of pavement engineering, performance, and behavior;
- The guidelines provided in the protocol should be adhered to in order to ensure that the widest benefit is obtained from the planned APT evaluations; and
- Pavement preservation APT should form part of a roads agency's broader research and development drive to ensure that all lessons learned are captured as part of the test, and that the focus is not only on small isolated effects.

ACKNOWLEDGMENTS

The author acknowledges the permission of the Executive Director of CSIR BE for permission to publish the information contained in this paper and acknowledges the comments and inputs from colleagues at CSIR BE.

REFERENCES

1. Metcalf, J. B. *NCHRP Synthesis of Highway Practice 235: Application of Full-Scale Accelerated Pavement Testing*. Transportation Research Board, National Research Council, Washington, D.C., 1996.
2. Hugo, F., and M. A. L. Epps. *NCHRP Synthesis of Highway Practice 325: Significant Findings from Full-Scale Accelerated Pavement Testing*. Transportation Research Board of the National Academies, Washington, D.C., 2004.

3. Steyn, W., M. De Beer, and A. T. Visser. Thin Asphalt and Double Seal Rehabilitated Lightly Cemented Pavements: Evaluation of Structural Behaviour and Life Cycle Costs. In *Eight International Conference on Asphalt Pavements, Volume II*, University of Washington, Seattle, 1997, pp. 1181–1201.
4. Steyn, W. Aspects of the Structural Performance of Rehabilitated Lightly Cemented Pavements. M.Eng. dissertation. University of Pretoria, South Africa, 1996.
5. Strauss, P. J., J. Du Plessis, V. Francis, and A. W. Viljoen. The Application and Validation of an Analytical Method in the Structural Rehabilitation of a Cracked Rigid Pavement. *Proc., Annual Transportation Convention*, Pretoria, South Africa, 1998.
6. Harvey, J., C. Rust, N. Coetzee, W. Nokes, and J. Van Kirk. Overview of Caltrans Accelerated Pavement Testing Pilot Project. *Proc., Fourth International Conference on the Bearing Capacity of Roads and Airfields*, Vol. II, University of Minnesota, Minneapolis, July 17–21, 1994, pp 1533–1548.
7. Van der Merwe, C. J., H. L. Theyse, E. Horak, F. Hugo, and H. A. Du Plessis. Evaluation of the Rehabilitation Design of a BTB and the Effects of Artificial Aging Using Accelerated Wheel Load Testing. *Proc., Seventh International Conference on Asphalt Pavements*, Vol. 3, Nottingham, United Kingdom, 1992.
8. Paige-Green, P. Aggregate Strength for Bituminous Surfacing for Low-Volume Roads: A Heavy Vehicle Simulator Experience. *Proc., 8th Conference on Asphalt Pavements for Southern Africa*. Sun City, North West Province, South Africa, September 12–16, 2004.
9. Paige-Green, P. The Use of Marginal Aggregates in Bituminous Seals. *Proc., 20th ARRB Conference*. Melbourne, Australia, March 19–21, 2001.
10. Rust, F. C., and C. M. MacCarron. Evaluation of Roadfix for Pothole Filling Through Laboratory Testing and Accelerated Trafficking. Contract Report, Division of Roads and Transport Technology, CSIR, Pretoria, South Africa, May 1989.
11. Kannemeyer, L., B. D. Perrie, P. J. Strauss, and L. Du Plessis. Ultra-Thin CRCP: Modeling, Testing Under Accelerated Pavement Testing and Field Application for Roads. Presented at 7th International CROW Workshop on Fundamental Modeling of the Design and Performance of Concrete Pavements, Belgium, September 15–16, 2006.
12. Steyn, W., and B. M. J. A. Verhaeghe. HMA Research Plan: Assessment of the Permanent Deformation Characteristics of a Standard HMA Mix. Approved project proposal for the Gauteng Department of Public Transport, Roads and Works, November 2006.
13. First International Conference on Accelerated Pavement Testing, Reno, Nevada, October 18–20, 1999.
14. Second International Conference on Accelerated Pavement Testing, Minneapolis, Minnesota, September 25–29, 2004.
15. Kong Kam Wa, N., B. M. J. A. Verhaeghe, H. L. Theyse, and E. C. Knottenbelt. Stiffness and Fatigue Characteristics of Some Asphalt Wearing Courses Used in South Africa. *Proc., 8th International Conference on Asphalt Pavements*, Seattle, Washington, August 10–14, 1997.

Minnesota Road Research Project Mainline Maintenance Observations and Test Track Lessons Learned, 2003–2006

BENJAMIN J. WOREL

TIMOTHY R. CLYNE

Minnesota Department of Transportation

The Minnesota Department of Transportation (MnDOT) built the Minnesota Road Research Project (MnROAD) between 1990 and 1993. Over the years the environment and traffic have caused the hot-mix asphalt test cells to both crack and rut, affecting the ride. In 2003 MnROAD performed a number of maintenance treatments to improve the ride quality until future reconstruction could be scheduled and to evaluate different maintenance treatments and their effectiveness. MnROAD and the Office of Maintenance used this opportunity to provide detailed pavement performance evaluations on the effectiveness of surface treatments and how pavement engineers can use them. An opportunity to try both experimental and existing techniques and materials targeted for use in northern climates was also offered. This can assist in selecting “the right treatment for the right road at the right time.” Slurry seals were placed in 2003 and the performance has been tracked. Treatments included both one and two lift slurry seals consisting of microsurfacing, placed by a contractor using a 12-ft box machine; and MiniMac, placed by MnDOT crews using a 6-ft box machine owned by MnDOT. One cell used a combination of both systems. Transverse crack repairs were also studied using two types of mastics along with the slurry from the MiniMac to fill cupped areas around the crack. Some of the cells may have deteriorated past the point of placing a preventive maintenance treatment but still provided an excellent opportunity to observe performance. Lessons were also learned about the use of an accelerated pavement test track to evaluate maintenance treatments.

The Minnesota Department of Transportation (MnDOT) constructed the Minnesota Road Research Project (MnROAD) between 1990 and 1993. MnROAD is located along Interstate 94 40 mi northwest of Minneapolis–St. Paul. It is an extensive pavement research facility consisting of both an Interstate mainline and a low-volume road that originally contained 40 test cells. Each MnROAD test cell is approximately 500 ft long. Subgrade, aggregate base, and surface materials as well as roadbed structure and drainage methods vary from cell to cell. The flexible pavement cells used two different asphalt binders: PG 58-28 and PG 64-22. All data presented herein, as well as historical sampling, testing, and construction information, can be found in the MnROAD database and in various publications. Additional information on MnROAD can also be found at <http://mnroad.dot.state.mn.us/research/mnresearch.asp>.

MAINLINE TEST CELLS

The mainline consists of a 3.5-mi two-lane Interstate roadway, and the test cells have both 5-year and 10-year pavement designs. Originally, a total of 23 cells were constructed consisting of 14 hot-mix asphalt (HMA) cells and nine portland cement concrete test cells. Traffic on the mainline comes from the traveling public on westbound I-94. Typically the mainline traffic is switched to the old I-94 westbound lanes once a month for 3 days to allow MnROAD researchers to safely collect data. Over time the mainline has received approximately 6 million flexible

equivalent single-axle loads (ESALs) and 10 million rigid ESALs as of December 2005. Figure 1 shows the layout of the mainline test cells.

PRE-EXISTING CONDITIONS

Over the years the environment and traffic have caused the HMA test cells to both crack and rut affecting the ride. MnROAD was expecting to reconstruct them in the near future, and this maintenance research fit nicely into our planned reconstruction. Ideally we would have placed these maintenance treatments earlier in the pavement's life, but MnROAD needed to follow the deterioration curve past the point of normal maintenance guidelines. In general MnROAD mainline HMA test cells have experienced the following deterioration (1).

Rutting

- The majority of the test cells contained 0.25 to 0.50 in. of rutting.
- The two binders used on the mainline performed according to the PG grading (PG 58-28 rutted more than the PG 64-22).
- Approximately 50% of the rutting at MnROAD developed in the first 3 years.
- Forensic rutting studies found the majority of the rutting developed in the top two lifts of HMA (3 in.) and no rutting was measured in the base or the subgrade.

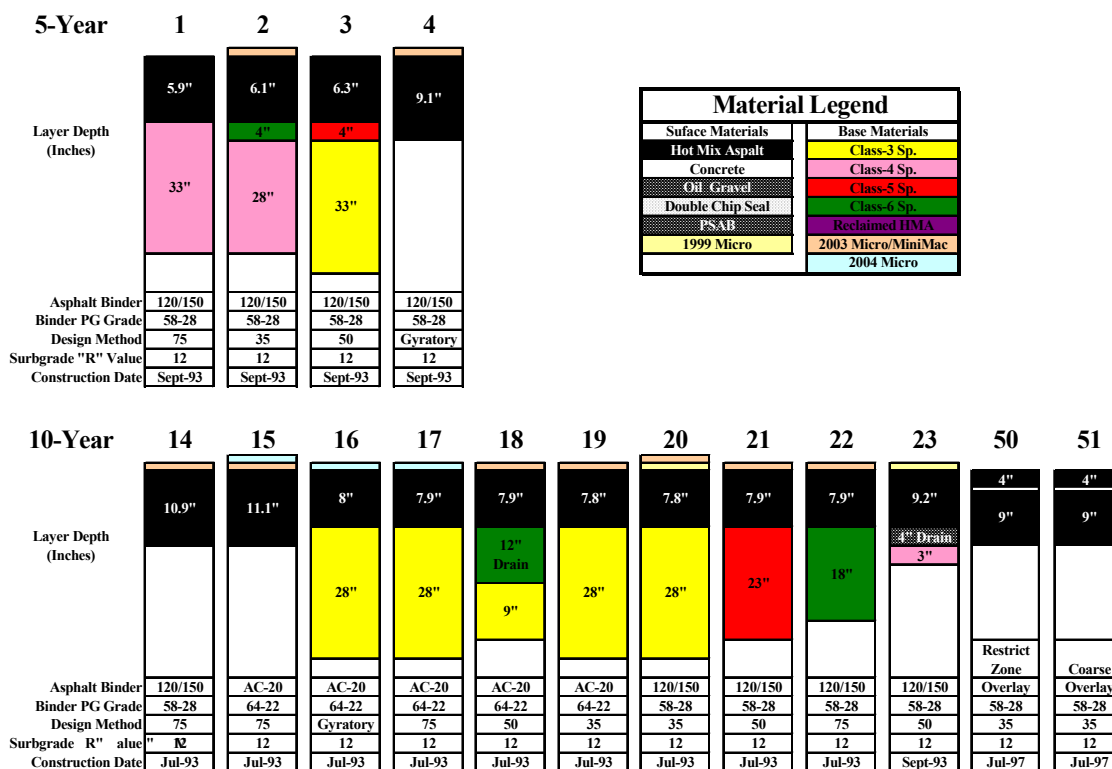

FIGURE 1 MnROAD mainline HMA cell layouts.

Transverse Cracking

- The majority of the test cells contained 200 to 500 linear feet of cracking.
- The two binders used on the mainline performed according to the PG grading (PG 64-22 cracked more than the PG 58-28).
 - Thickness was not a factor in transverse cracking.
 - All of the original test cells developed the majority of the transverse cracking in the winter of 1996 when the temperatures one week reached a minimum of -39°F . Very little additional thermal cracking has developed since then.
 - Transverse cracking has increased in severity level and cupping (depression over the crack) with traffic over time.

Top Down Cracking

- The amount of top down cracking varied widely among cells, from 44 to 1,000 linear feet of cracking.
 - Neither PG grading, thickness, mix design (blows–asphalt content), nor traffic seemed to be a factor in the amount of cracking.
 - Eight of the 14 cells contained over 50% cracking (wheelpaths) in 2003. The first top down cracking was recorded on Cell 22 in April 1996.
 - Forensic investigations found the majority of the cracking stopped at the first and second lift interface.

Ride

- The range of the international ride index was 1.04 to 3.57 m/km.
- The cells with more cupped transverse cracking and top-down cracking in the wheel paths had larger international roughness index (IRI) values (poor ride).
- Thickness does not impact ride deterioration.

2003 MAINTENANCE PLAN

The goal of the maintenance treatments was to restore ride to the HMA cells using typical preventive maintenance activities and to study the effectiveness of these activities either alone or in combination. The 2003 maintenance activities at MnROAD took place throughout the spring and summer months. The work consisted of resealing cracks with a crumb rubber sealant, leveling cupped transverse cracks with mastic materials or slurry, and applying a thin maintenance surface across the entire test cell. MnDOT typically expects 7 to 10 years of extended life from the following slurry seals if placed at the appropriate time in a pavement's deterioration. [Table 1](#) shows the activities completed for this experiment using the following maintenance methods (2):

Control Cells

No maintenance activities were performed.

TABLE 1 MnROAD Maintenance Study Matrix, 2003

Cell	Reseal Cracks	Transverse Crack Repair ^b	MiniMac Slurry Seal–Microsurfacing	
		Both Lanes	Passing Lane (#) Layers	Driving Lane (#) Layers
1	Yes	Crack Reseal Only		
2	Yes		MiniMac (1)	MiniMac (2)
3	No	Control Cell: No Maintenance Work Performed		
4	Yes	Mastic	Micro (2)	Micro (2)
14	Yes	Mastic	MiniMac (2)	MiniMac (2)
15	Yes	MiniMac	Micro (1) over MiniMac (1)	Micro (1) over MiniMac (1)
16	Yes	Mastic		
17	No	Control Cell: No Maintenance Work Performed		
18	Yes	Mastic	Micro (1)	Micro (2)
19	Yes		Micro (1)	Micro (1)
20 ^a	Yes		Micro (1)	Micro (1)
21	Yes		Micro (1)	Micro (2)
22	Yes		Micro (1)	Micro (1)
23 ^a	Yes	Crack Reseal Only		

NOTE: Cell was microsurfaced in 1999. The mastic materials used for leveling of cupped transverse cracks were installed with each product in one half of each cell in both the driving and passing lanes.

Crack Resealing

Cracks were resealed with a hot-poured, crumb rubber-type sealant meeting MnDOT Specification 3179. The “Clean and Go” installation method was used. Only the transverse and centerline cracks were resealed; longitudinal cracks were not sealed.

Transverse Crack Mastic Leveling

Two mastic products from different manufacturers were applied in equal halves of certain cells. The materials were studied for their effectiveness in leveling cupped transverse cracks and delaying reflective cracking. The products are hot-poured mastics composed of aggregates, polymer modified asphalt binders, and fillers.

MiniMac “Slurry Seals”

MnDOT personnel applied slurry seals to fill longitudinal rutting (6-ft box) and to level transverse cracks (2-ft box), with an added result of improving surface texture. The slurry seal mix design consisted of a type II (FA-2) aggregate latex-modified emulsified asphalt binder, cement, and water.

Microsurfacing “Slurry Seals”

Microsurfacing work was performed using a continuous paver machine (12-ft box) operated by a contractor to fill the rutting in both lanes and to improve texture. The microsurfacing mix design consisted of a type II (FA-2) aggregate polymer-modified emulsified asphalt binder, cement, and water.

MAINTENANCE TREATMENT PERFORMANCE OBSERVATIONS

The slurry seals used in this study were developed primarily as a stiff material used to fill the ruts, improve the ride, protect the pavement surface from the effects of weather and sunlight, and restore surface texture. The mixes were placed in 2003 and have been monitored for the last three years. The observations related to reflective cracking, rutting, and ride are listed below.

Reflective Cracking Observations

Microsurfacing or MiniMac materials are designed to prevent rutting, but this leads to a brittle mix that is susceptible to cracking. As expected, we observed that reflective cracking took place shortly after placement of the slurry seal (MiniMac or microsurfacing), even before our first distress survey after construction. As a result, the slurry treatments were somewhat ineffective in reducing reflective top-down cracking (longitudinal wheelpath) and often led to higher severity reflective transverse cracking. [Figure 2](#) shows a reflected transverse crack through the slurry seal.

Transverse Cracking

[Figure 3](#) shows the progression of transverse cracking after the maintenance treatments were placed. The control and crack seal only sections had virtually no change, although the total length of transverse cracking observed has increased slightly over 3 years. Mastic treatments did not prevent the cracks from returning. The other combinations of slurry seal treatments were somewhat successful in reducing transverse cracks, although a majority of the cracks reflected through after 1 year. The single and double treatments with crack repair initially did the best job in preventing reflective cracks, but after 3 years of performance monitoring the double slurry seal without crack repair was performing the best. The cracks in the control cells (1, 3, 17, and 23) maintain their severity levels, while cells that received either microsurfacing or MiniMac slurries show a greater increase in medium severity cracking. This may be due to slurry breaking in a “V” from the single crack causing a wider crack on the surface. Cells 15, 16, and 17 received another lift of microsurfacing in 2004 due to reflective cracking and a related decrease in ride quality from those cracks.

Top-Down Cracking

[Figure 4](#) shows the reemergence of top-down cracking after the maintenance treatments were placed. Only the slurry seal treatments and control sections are shown in the figure, since the other maintenance treatments were targeted to reducing transverse cracking. The slurry seals



FIGURE 2 Reflected transverse crack through the slurry seal .

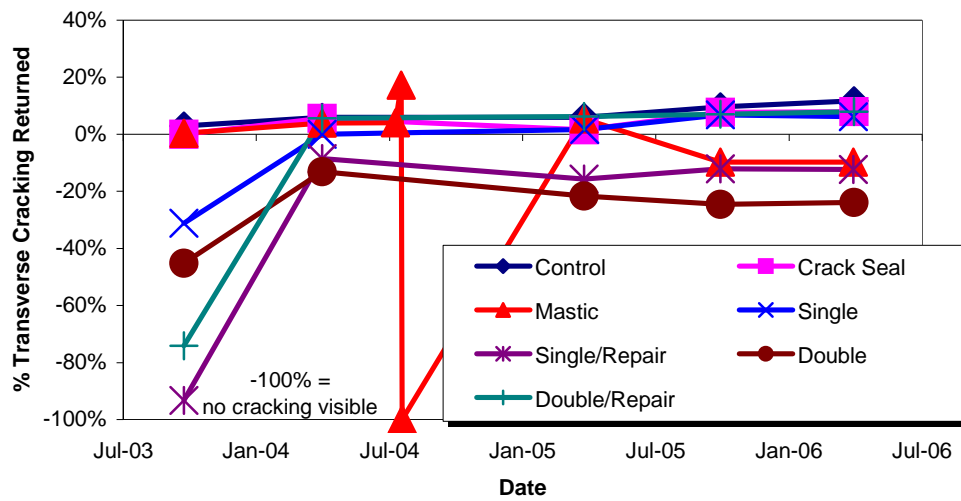

FIGURE 3 Change in reflective (transverse) cracking since maintenance activities.

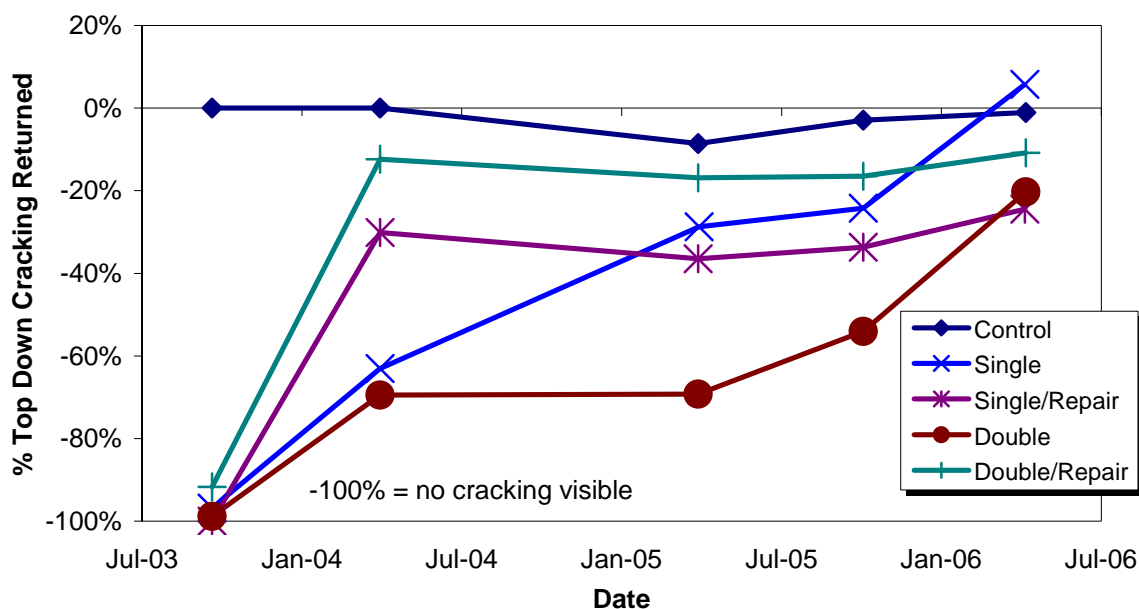

FIGURE 4 Change in reflective (top down) cracking since maintenance activities.

were more successful in retarding the top-down cracking progression. Virtually none of the cracks were visible during an October distress survey, but many of the top-down cracks reflected through after the first winter. The single slurry with transverse crack repair and the double slurry treatments did the best job of reducing reflective top-down cracking initially and after 3 years of performance monitoring. Today a majority of the cracks are back to their pre-maintenance conditions. Only Cell 19 has less than 50% of the top-down cracking reflected through, and many cells contain more cracking than was evident before the slurry seals.

Rutting Observations

Rutting on the MnROAD cells occurred mostly in the first 2 years and leveled off in the following years. Microsurfacing or MiniMac materials are designed to prevent rutting and have worked reasonably well on the mainline cells. The 2003 treatments were not as effective at reducing the rutting as previous efforts using microsurfacing in 1999, in which the rutting for Cells 20 and 23 have been reduced to less than half of their original rutting recorded when the work was completed. Figure 5 shows the rutting history of Cells 2 and 20 for comparison purposes. The slurry seals placed in 2003 caused a larger reduction in rutting on Cell 2 than on Cell 20. The rutting on both cells has continued to increase since placement of the maintenance treatments.

It was also found that two slurry seal lifts are better than one lift and that one lift is better than nothing in terms of filling in ruts in the pavement. Table 2 shows the current rutting measurements on the MnROAD cells. The majority of the cells have between $\frac{1}{4}$ and $\frac{1}{2}$ in. of rut depth, with three of the cells above the threshold MnDOT considers to be potentially hazardous ($\frac{1}{2}$ in.).

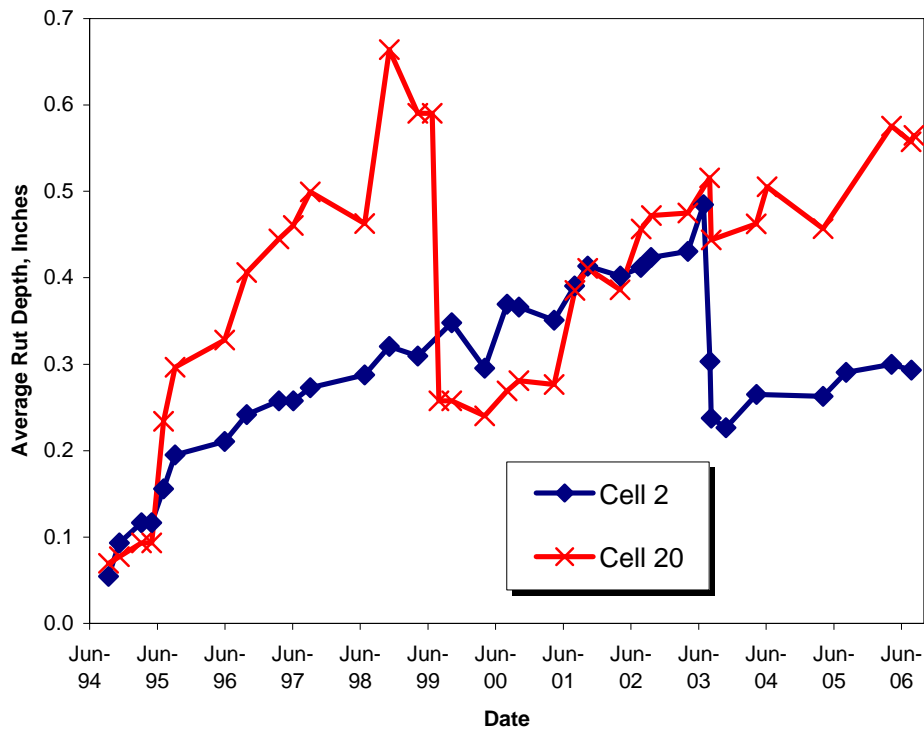

FIGURE 5 Rutting history of Cells 2 and 20.

TABLE 2 MnROAD Rut Depth Measurements (Driving Lane), 2006

Cell	Rut Depth, inches
1	0.46
2	0.29
3	0.41
4	0.50
14	0.33
15	0.29
16	0.27
17	0.32
18	0.33
19	0.43
20	0.56
21	0.51
22	0.36
23	0.36

Ride Observations

Ride quality related to both microsurfacing and MiniMac “slurry seals” are mostly dependent on the amount of reflective cracking (both top down and transverse) that develops in the wheelpaths. Some debonding of the slurry seals was observed over crack sealant, which also caused rougher ride. MnROAD uses its pavement management PathWays van to collect ride in terms of IRI measured in meters/kilometer. Figure 6 shows the effects of the maintenance treatments on ride quality. The control cells showed virtually no change in roughness since the maintenance treatments, while those with crack seal have been getting progressively worse over time. The best performers were the single and double slurry treatments with transverse crack repairs (both mastics and MiniMac applications). The cells with mastic and single slurry treatments have come back to pre-maintenance roughness measurements. The cells that received other slurry seal treatments have retained their ride quality 3 years after the maintenance treatments. Cells 14, 15, and 16 received another lift of microsurfacing in 2004 due to reflective cracking and related ride quality from those cracks.

FACILITY MAINTENANCE LESSONS LEARNED

MnROAD has learned from each of its efforts, and providing test cells for research activities has been beneficial both to the researchers and to the facility. Following are several lessons learned.

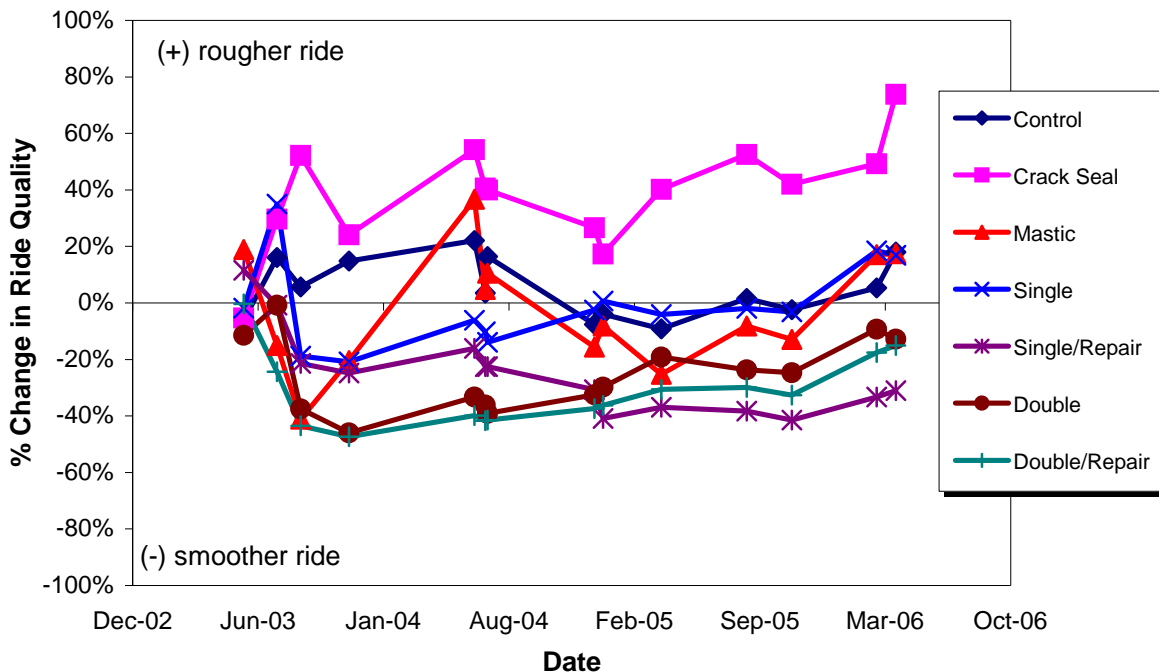

FIGURE 6 Change in ride quality since maintenance activities.

- Questions occasionally arise as to whether or not a 500-ft cell is representative of a larger pavement section and if researchers can learn anything in such a short distance, not to mention if quality construction is even possible in a cell. It has been our experience that significant differences in performance have been observed between cells, allowing researchers to draw valid conclusions. In addition, we have not had a problem with construction in 500-ft increments.
 - Maintenance treatments have allowed MnROAD to delay reconstruction, while allowing shorter-term research to be conducted at a national facility.
 - MnROAD strikes an appropriate balance between the environmental and traffic loading factors that affect maintenance treatment performance.
 - The layout of MnROAD, with its isolated low-volume road and the ability to switch traffic on and off the mainline, allows for detailed measurements on the maintenance treatments to be taken in a safe, consistent manner.

CONCLUSIONS

The maintenance research performed at MnROAD in 2003 has yielded valuable results both for researchers and practicing construction and maintenance engineers. Slurry seals have performed quite well in terms of restoring ride quality, and they have done an adequate job of filling in ruts. None of the maintenance treatments studied was successful in preventing reflective cracking from underlying transverse or top down cracks. Under appropriate conditions, slurry seals can be used for an effective maintenance treatment. MnDOT will continue to monitor the performance of the maintenance activities placed in 2003. To this point, the materials have survived Minnesota's winters with their cold temperatures and snowplows, an aspect that will be critical to the continuing successful use of these products.

REFERENCES

1. Palmquist, D., B. Worel, and W. Zerfas. *2002 MnROAD Hot-Mix Asphalt Mainline Test Cell Condition Report*. Minnesota Department of Transportation, 2002.
2. Zerfas, W. J., R. Mulvaney, and B. Worel. MnROAD Mainline 2003 Maintenance Activities for Hot Mix Asphalt Test Cells. *Proc., 2nd International Conference on Accelerated Pavement Testing* (CD-ROM), Minneapolis, Minn., September 26–29, 2004.

THE NATIONAL ACADEMIES

Advisers to the Nation on Science, Engineering, and Medicine

The **National Academy of Sciences** is a private, nonprofit, self-perpetuating society of distinguished scholars engaged in scientific and engineering research, dedicated to the furtherance of science and technology and to their use for the general welfare. On the authority of the charter granted to it by the Congress in 1863, the Academy has a mandate that requires it to advise the federal government on scientific and technical matters. Dr. Ralph J. Cicerone is president of the National Academy of Sciences.

The **National Academy of Engineering** was established in 1964, under the charter of the National Academy of Sciences, as a parallel organization of outstanding engineers. It is autonomous in its administration and in the selection of its members, sharing with the National Academy of Sciences the responsibility for advising the federal government. The National Academy of Engineering also sponsors engineering programs aimed at meeting national needs, encourages education and research, and recognizes the superior achievements of engineers. Dr. Charles M. Vest is president of the National Academy of Engineering.

The **Institute of Medicine** was established in 1970 by the National Academy of Sciences to secure the services of eminent members of appropriate professions in the examination of policy matters pertaining to the health of the public. The Institute acts under the responsibility given to the National Academy of Sciences by its congressional charter to be an adviser to the federal government and, on its own initiative, to identify issues of medical care, research, and education. Dr. Harvey V. Fineberg is president of the Institute of Medicine.

The **National Research Council** was organized by the National Academy of Sciences in 1916 to associate the broad community of science and technology with the Academy's purposes of furthering knowledge and advising the federal government. Functioning in accordance with general policies determined by the Academy, the Council has become the principal operating agency of both the National Academy of Sciences and the National Academy of Engineering in providing services to the government, the public, and the scientific and engineering communities. The Council is administered jointly by both the Academies and the Institute of Medicine. Dr. Ralph J. Cicerone and Dr. Charles M. Vest are chair and vice chair, respectively, of the National Research Council.

The **Transportation Research Board** is one of six major divisions of the National Research Council. The mission of the Transportation Research Board is to provide leadership in transportation innovation and progress through research and information exchange, conducted within a setting that is objective, interdisciplinary, and multimodal. The Board's varied activities annually engage about 7,000 engineers, scientists, and other transportation researchers and practitioners from the public and private sectors and academia, all of whom contribute their expertise in the public interest. The program is supported by state transportation departments, federal agencies including the component administrations of the U.S. Department of Transportation, and other organizations and individuals interested in the development of transportation. www.TRB.org

www.national-academies.org



TRANSPORTATION RESEARCH BOARD

500 Fifth Street, NW

Washington, DC 20001

THE NATIONAL ACADEMIES™

Advisers to the Nation on Science, Engineering, and Medicine

The nation turns to the National Academies—National Academy of Sciences, National Academy of Engineering, Institute of Medicine, and National Research Council—for independent, objective advice on issues that affect people's lives worldwide.

www.national-academies.org