

# SIMRAC

## Final Project Report

Title: HANDBOOK TO REDUCE THE EXPOSURE OF  
WORKERS TO DUST

Author/s: Members of the Special Interest Group on Dust and  
Ventilation

Research  
Agency: CSIR, Miningtek

Project No: COL 027

Date: APRIL 1996

## **PREFACE**

An urgent need has been identified by the coal mining industry, the Department of Mineral and Energy Affairs, and the unions regarding information to enable mine operators to address the dust problem. This handbook flows out of a SIMRAC funded project dealing with dust, and part of the project's output was to update the previous guidelines, making it pertinent to catering for the ventilation and dust suppression systems, which are presently being used on the mines.

This handbook is directed at personnel on the mines, allowing an understanding, not only the problem, but also of the processes which can be used to combat the occurrence of dust in the workings. It is also envisaged that the handbook will serve as a reference base for those in supervisory positions, and those responsible for maintaining lower levels of dust.

This book has been drawn up by staff of Miningtek with the invaluable assistance from members of the Special Interest Group on Dust Suppression (SIGDS).

The following persons were instrumental in the writing of this handbook

C Meyer  
JJL Du Plessis  
JW Oberholzer.

The following persons assisted with editing, advice, technical input:

J Guthrie  
J Beukes  
G Van Tonder  
A Tatton  
J Diederichs.

The MBD of Miningtek is acknowledged for the preparation of the Draft into a final document and the drawing of the illustrations.

## CONTENTS

1.	INTRODUCTION	1
2.	FUNDAMENTALS	3
3.	A STRATEGY TO REDUCE WORKER EXPOSURE TO DUST	24
4.	MEASUREMENT OF DUST	31
5.	REDUCING THE MAKE OF DUST AND PREVENTING IT FROM BECOMING AIRBORNE	38
6.	DUST SCRUBBERS	47
7.	WATER APPLICATION	62
8.	VENTILATION	74
9.	THE USE OF COMPUTATIONAL FLUID DYNAMICS	115
	REFERENCES	142

## LIST OF TABLES

### CHAPTER 2

1.	Approximations of the coefficient of drag for spherical particles	17
2.	Results	19
3.	Pick-up velocities for coal and quartz particles	23

### CHAPTER 7

1.	Examples of optimum spray nozzles for dust control	69
----	--	----

## LIST OF FIGURES

### CHAPTER 2

2.1	Respirable sampling curve defined at the International Conference in Jhb, 1959	6
2.2	Forces acting on a dust particle	16

### CHAPTER 4

4.1	Isokinetic sampling	36
-----	---------------------	----

## CHAPTER 6

6.1	Daily maintenance	55
6.2	Periodical maintenance	56

## LIST OF FIGURES

### CHAPTER 5

5.1	Forces during cutting process	39
5.2	Comparison between blunt and sharp picks in the creation of dust	41
5.3	Effects of changing the ration between DOC and pick spacing	42

### CHAPTER 6

6.1	Process of impaction	49
6.2	Process of interception	51
6.3	Diffuse particle collection	52
6.4	Flooded-bed scrubber layout	53
6.5	Wet fan scrubber layout	54
6.6	Demister baffle design	59
6.7	Phase separation	59

### CHAPTER 7

7.1	Nomogram for determining of static pressure at a given depth of mining	63
7.2	Nomogram for determination of pressure losses (per 100 m) at given flow rates in schedule 40 pipes	63
7.3	Nomogram for determining of pressure drops at a given flow rate in trailing water hoses of various internal diameters	65
7.4	Various nozzle types	68
7.5	Typical spray positions on a continuous miner	70
7.6	Typical venturi dust suppression system	70

### CHAPTER 8

8.1	Sketch showing the definition of air recirculation	74
8.2	Sketch showing the definition of air reinducement	75
8.3	Sketch showing the definition of fresh entrainment	76
8.4	Sketch showing the normal behaviour of air when flowing past an empty heading	77
8.5	Airflow patterns with a fan installed upstream	78
8.6	Airflow patterns with a fan installed downstream	78
8.7	Section ventilated by the coursing method	80
8.8	Section ventilated by the splitting method	82
8.9	Headings ventilated by means of force ventilation with ducting	84
8.10	Airflow patterns with a force duct, on-board scrubber and exhaust column in use	85
8.11	Installation of a scoop brattice inside a heading	86
8.12	Sketch showing a trailing exhaust connected to a scrubber outlet	87
8.13	Sketch showing the different positions for the spray nozzles	88

8.14	Typical airflow patterns around the cutting drum with the directional sprays in use	88
8.15	Sketch showing the normal "U" shape airflow pattern	92
8.16	Sketch showing the "figure of eight" airflow pattern	93
8.17(a)	Split development from road 5 to road 4	95
8.17(b)	Split development from road 4 to road 5	96
8.17(c)	Sketch shows the second stage of the development with jet fan	97
8.18(a)	Split development from road 1 to road 2	98
8.18(b)	Split development from road 2 to road 1	99
8.18(c)	Sketch shows the second stage of development with a jet fan	100
8.19	Second stage of the development against the flow of air	101
8.20	Second stage of the development with the flow of air	102
8.21	Using "over the goaf" ventilation towards a bleeder road at back of the goaf	104
8.22	Utilizing the return airway of an adjacent section as a bleeder road	105
8.23	No bleeder road system used, with additional force ventilation to supply fresh air over the driver	106
8.24	Pillars extracted in a 45° line with no bleeder road or "over the goaf" system used	108
8.25	Pillars extracted in a 45° line, use is made of the return airway of an adjacent section	109
8.26	Rib-pillar extraction ventilation layout during the development and extraction process	110
8.27	Ventilation layout during the development of the bleeder road, secondary and tertiary development for rib-pillar extraction	112
8.28	Ventilation layout for the extraction of the fenders during the rib-pillar development	113

## CHAPTER 9

9.1	Geometry of a roadheader model	117
9.2	Geometry of a continuous miner model	117
9.3	Geometry of an airjet fan	118
9.4	Position of horizontal and vertical planes for representing data	119
9.5(a)	Detail of velocity vectors on x-z planes in the vicinity of the machine	120
9.5(b)	Detail of velocity on x-y planes in the vicinity of the machine	120
9.6	Examples of air flowing in the x-direction inside a heading	121
9.7(a)	Isosurface showing the air from the fan flowing in a forward direction at a certain velocity	123
9.7(b)	Isosurface showing the air from the fan flowing backwards from the face towards the LTR at a certain velocity	123
9.8	Flow lines indicating the flow of respirable dust particles	124
9.9	Velocity vectors at 0,75 m from the floor above the gathering arms	126
9.10	Velocity vectors at 2,8 m from the floor at operator level	128
9.11	Velocity vectors at 4,1 m from the floor, just below the roof	129
9.12	Velocity vectors showing the vertical movement of the air around the machine	130
9.13(a)	Velocity contours showing the airflow in the x-direction	133
9.13(b)	Line contours showing the airflow in the x-direction	134
9.14(a)	Velocity contours showing the airflow in the y-direction	136
9.14(b)	Line contours showing the airflow in the y-direction	137
9.15(a)	Velocity contours showing the airflow in the z-direction	138
9.15(b)	Line contours showing the airflow in the z-direction	139
9.16	Dust concentration contours presented in a three dimensional manner	141

# 1 INTRODUCTION

1.1	Objective of this document	1
1.2	The problem being addressed	1
1.3	Dust as the problem	2
1.4	Short form strategy	2
1.5	There is nothing new	2

# 1 INTRODUCTION

## 1.1 Objective of this Document

The objective of this document is to address the identified knowledge gap which exists in the coal mining industry relating to matters dealing with all aspects of dust and dust suppression. The document is expressly directed at the South African coal mines and the problems experienced in the coal face and outbye areas. The problems addressed are those that are experienced by the South African Coal mining industry, which due the way in which coal is extracted, has some unique conditions.

In drawing up the book cognisance was taken of the latest technologies which are employed on the mines, as well as the legal framework in which these technologies are applied. The use of modern tools and instruments, as well as the latest methods of evaluating ventilation methods have also been included.

As this handbook is to be used by a diverse level of mine staff, ease of reading and understanding was strived for at all times.

## 1.2 The Problem Being Addressed

Since the introduction of continuous miners in the mid 1970's the amount of coal mined by this method has risen significantly. Not only has the number of continuous miners in operation risen, but so also the capacity of the machines to extract coal. Even now there is a striving for machines which extract coal at a faster rate, so the required increase in production rates can be satisfied

The problem with continuous miners is not that the breaking of coal causes dust, because use of explosive also causes large amounts of dust. The problem is firstly the generation of dust takes place over a significantly longer period (compare the time of a blast in a face with that of a continuous miner cutting coal), and secondly in the case of continuous miners, the operators are present throughout the whole process. It is thus not the amount of coal dust that is generated that is the real problem, but rather the way that the use of continuous miners increase the exposure of workers to dust.

The matter is further exacerbated by the fact that the ventilation system must now not only cater for a plug of dusty air, but for adequate ventilation during the whole period when the continuous miners are operational.

Although practical and workable solutions for coping with these problems have been developed overseas, the present mining layouts, deeper cuts in the heading and the seam heights at which is being mined all contribute to making the ventilation of the face much more complex and therefore more difficult to control. Easy solutions where-in the engineering specifications of the air movers are laid down is, unfortunately, inadequate to provide the required results. Use of more sophisticated methods have become necessary to determine the best solution for the particular circumstance

Although the full impact was not fully understood the Coal Mining Industry, in May 1993, identified ventilation as the single most important contributor to the achievement of lower dust levels in a section. The decrease of small coal, by increasing the efficiency of the cutting process, was seen to be the longer term solution. In addressing this ventilation problem, all the air movers had to be considered. This included the section ventilation, secondary fans, spray-fan air moving mechanisms, as well as scrubbers. The use of air-jet



fans also play a significant role and were incorporated into the investigation.

### 1.3 Dust as the Problem

Coal which is finely broken up can more readily be ignited and therefore poses a safety risk as it is the fuel for an explosion. Furthermore its very presence can make a low methane concentration more readily explosive. This dust is in the larger size fraction (+ 20 micron), is readily visible with the eye, creating a further safety hazard as it causes a lowering of the visibility in the heading. Accumulating in areas, in and on the machine, it downgrades the general condition of the equipment.

The finer fraction of coal dust, lying in the minus 10 micron range is called respirable because it can be inhaled into the lungs. This dust is mainly a health hazard. The effects of being subjected to respirable dust does not have an immediate effect but could cause black lung or other lung diseases over the longer term. The hazard is made worse when quartz is present in this dust, as it can cause silicosis.

The larger fraction of the repairable dust is called thoracic dust and, although not causing damage in the lungs, can cause irritations in the airway leadings to the lungs and could be the cause of throat and bronchial diseases.

The presence of dust also has a direct influence on the production of an section. Apart from the fact that workers are more comfortable when there is no dust in the air it causes visibility problems. The lack of visibility can cause problems with horizon control, which in turn can lead to the continuous miner cutting in the roof stone. The effect of this is an increased usage of picks as well as an uneven roof.

### 1.4 Short Form Strategy

In addressing the dust problem this document uses the following strategy to reduce the exposure of humans to dust.

- Reduce the amount of dust produced
- Reduce the amount of dust released into the air
- Remove the dust from the air
- Remove the dust laden air
- Keep the installed dust allaying systems working.

### 1.5 There is Nothing New

The majority of principles used in this book are not new and have been much publicised These principles and methods have been adapted for use in South African collieries

It is hoped that by using this book, management might bring about the required changes to their systems so that dust levels in South African collieries can be dropped and maintained at acceptable levels

## 2 FUNDAMENTALS

2.1	Introduction	3
	2.1.2 Toxicity and exposure limits	4
2.2	Classifications of Dust	4
	2.2.1 Size distribution of particles	4
	2.2.2 Physiological and physical effects of dust	6
2.3	Effects of Dust	7
	2.3.1 Effects on health	7
	2.3.2 Effects on safety	10
	2.3.3 Effects on productivity	11
	2.3.4 Explosions	11
2.4	Sources of Dust	11
	2.4.1 Sources outby of the face	12
	2.4.2 Conventional mechanised mining	13
	2.4.3 Mechanical miner mining	14
	2.4.4 Longwall mining	14
2.5	Behaviour of Dust	15
	2.5.1 Aerodynamic movement of dust	15
	2.5.2 Spatial distribution of dust	21
	2.5.3 Time related occurrence of dust	22
	2.5.4 Air movement and dust	22

## FUNDAMENTALS

### 2.1 Introduction

The air that we breathe in contains various gases and solid and liquid particles. Such an inhalable atmosphere is known as an aerosol.

Aerosols can thus be defined as the suspension of solid or liquid particles in a gas. They are usually stable for at least a few seconds and, in some cases, may last more than a year. The term "aerosol" includes both the particle and the suspending gas and particle sizes ranging from 0.001 to over 100 micrometre ( $\mu\text{m}$ ). An aerosol in the context of this document would refer to dust particles in air. Dust is defined as a solid particle aerosol formed by mechanical disintegration of a parent material such as by crushing or grinding. The particle size of dust may range from submicrometre to visible.<sup>1</sup>

Airborne dust in coal mines is very complex, with material varying greatly in chemical, physical and mineralogical properties. The respirable dust contains other dust particles besides coal dust particles usually generated when roof, floor or parting cutting takes place, such as quartz.

Coal dust can be described as a polydispersed aerosol which means that a wide range of particle sizes are present in the dust. In general terms, coal dust is finely divided matter smaller than  $100\ \mu\text{m}$  and of sufficiently low mass and able to remain suspended in air for a relatively long time. Obviously, there are as many different types of dust as there are different materials, some dangerous, others not. We therefore classify dusts according to various criteria such as their toxicity, the concentration at which they are considered to be no risk to health and the fraction of the dust which is respirable and can enter the lungs.

Particle size, shape and density are important parameters for the characterising of the behaviour of dust. The most important parameter is the particle size as many properties of dust depend on it.

Particle size can refer to the radius or diameter of the particle. In the text size would refer to the diameter of the particle in  $\mu\text{m}$ . The particle sizes are defined in different size ranges (particle size distribution) which include submicrometre range ( $< 1\ \mu\text{m}$ ) and the micrometre size range ( $1 - 10\ \mu\text{m}$ ). Other particle size ranges for different types of dust will be defined later in the text.

Coal dust consists of particles that have complex shapes. In order to define their behaviour it is necessary to assume that the particles are spherical and to correct the results accordingly. A method of doing this is to redefine the particle size to an equivalent diameter. The equivalent diameter is the diameter of a sphere that would have the same value of a particular physical property as that of the irregular particle.

Other diameters that are frequently used are the Stokes diameter and the aerodynamic diameter. These diameters are equivalent diameters. For any particle they are defined as follows.

"The Stokes diameter ( $d_s$ ) is the diameter of the sphere that has the same density and settling velocity as the particle"

- "The aerodynamic diameter( $d_p$ ) is the diameter of the unit density ( $w_p = 1$  g/cm<sup>3</sup>) sphere that has the same settling velocity as the particle.<sup>1</sup>"

The particle density is normally defined as a mass per unit volume (g/cm<sup>3</sup>). Particle density is important as it is one of the parameters that influences the settling rate of dust particles.

The most important property from a viewpoint of health and safety is the dust mass concentration. The dust mass concentration is defined as the mass of particulate matter in a unit volume of air. Dust mass concentration is normally given in milligram per cubic metre (mg/m<sup>3</sup>).

## 2.1.2 Toxicity and exposure limits

The relative toxicity determines the maximum concentration to which most workers may be repeatedly exposed too without harmful effect. The American Conference of Governmental Industrial Hygienists(ACGIH) publishes a list of "Threshold Limit Value-Time Weighted Average(TLV-TWA) for Chemical Substances in the Work Environment", similar to the German "List of Maximum Concentrations at the Workplace and Biological Tolerance Values for Working Materials" published by the Deutsche Forschungsgemeinschaft.

At present the official South African standards and limits are set by the Department of Mineral and Energy Affairs in guidelines.<sup>2</sup>

The TLV-TWA values for coal dust (based on the DMEA guidelines) are:

2.0 mg/m<sup>3</sup>: respirable fraction < 5% Alpha quartz  
0.1 mg/m<sup>3</sup>: respirable fraction > 5% Alpha quartz

where 2.0 mg/m<sup>3</sup> refers to the respirable coal dust concentration and 0.1 mg/m<sup>3</sup> refers to the respirable quartz concentration in the respirable dust concentration.

The TLV-TWA is the threshold limit value for the single pollutant as normally predetermined by the GME. The time weighted average refers to a standard workday of eight hours and a workweek of forty hours. The TLV.TWA indicated above would ensure that a worker that is exposed to these limits would have no detrimental effect to his health over a normal working lifespan.

## 2.2 Classification of Dust

Aerosols can be classified in various ways depending on the purpose. Dust is classified in this context first with regards to the size distribution of the particles and secondly in terms of physiological effects

### 2.2.1 Size distribution of particles

In the process of mining, dust is created through impaction, abrasion, crushing, cutting, grinding and/or explosive energy. A wide range of particle sizes is created

in this process and can be classified as generated dust, airborne dust, respirable dust, inhalable dust and nuisance dust.

### (a) Generated dust

Generated dust is the dust particles created during a mechanical process in which solid material is broken into smaller fragments, not all of which become airborne as many of the particles adhere to the larger fragments.

Studies in the USA<sup>3</sup> have indicated that less than 1% of the dust particles generated during the cutting process becomes airborne while the bulk of the dust particles adheres to the larger fragments of coal.

### (b) Airborne dust (AD)

Airborne dust is frequently referred to as total dust. By this is meant the total size distribution measurement of dust particles in the ventilating air.

Airborne dust is that fraction of the generated dust which is entrained in the air. It is the total amount of dust and includes the respirable, inhalable dust and nuisance dust fraction ( $AD = RD + ID + ND$ ).

Airborne dust consists primarily of particles of sizes less than  $1 \mu\text{m}$  particles with a  $d_{50}$  of  $7 \mu\text{m}$ . The median diameter of airborne dust varies between 5 and  $10 \mu\text{m}$  with a top size in the order of  $65 \mu\text{m}$ .<sup>4</sup> For coal dusts the lower and upper limit of the size range is 0,1 to  $100 \mu\text{m}$ .

### (c) Respirable dust (RD)

Respirable dust is that fraction of the dust which is small enough to reach the human lung through respiration, usually assumed to be the size distribution as described by the so-called Johannesburg Curve, which was adopted at the 1959 Johannesburg Pneumoconiosis Conference (see Figure 1). This is a respirable sampling curve that is an indication of particle sizes constituting a health risk.

### (d) Inhalable dust (ID)

Inhalable dust is dust with an aerodynamic diameter of less than  $20 \mu\text{m}$  and may be deposited in the nose, throat and trachea with only part of the respirable fraction reaching the lungs. The part of the respirable dust reaching the lungs on inhalation is determined by the following process.

- (i) A certain percentage of the respirable dust is breathed out or swallowed,
- (ii) A portion of the dust settles out in the upper parts of the lungs and is removed

naturally within a few days; and

- (iii) A portion of the dust having a size range of between 1 - 5  $\mu\text{m}$  is retained in the air passage of the lung (the alveoli)<sup>27</sup>.

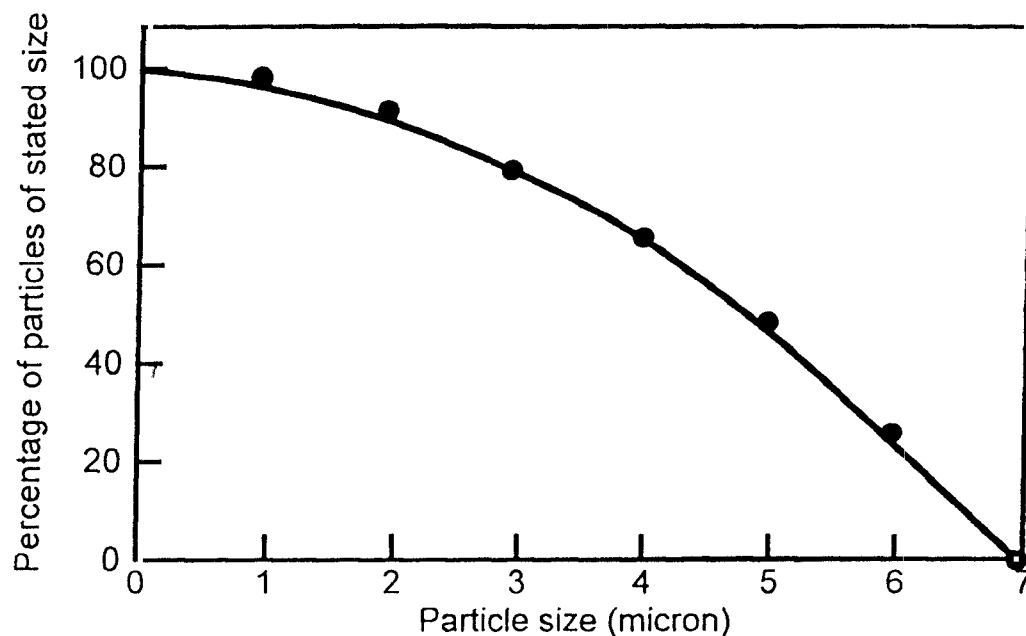

Figure 2.1 Respirable sampling curve defined at the International Conference in Johannesburg, 1959

Particles smaller than 7  $\mu\text{m}$  (equivalent diameter) are considered as respirable dust and the median diameter for respirable dust ranges from 1,7 to 3,2  $\mu\text{m}$ .

#### (e) Nuisance dust (ND)

Nuisance dust is that fraction of the dust which is too coarse to be breathed in or does not endanger health, but creates a nuisance when airborne in that it may damage machinery, diminish visibility or irritate workers without affecting their health.

### 2.2.2 Physiological and physical effects of dust

A classification of dusts with respect to potential hazard to the health and safety of subsurface workers may be divided into five categories, described by McPherson.<sup>28</sup>

- (i) *Toxic dusts*: These can cause chemical reactions within the respiratory system or allow toxic compounds to be absorbed into the bloodstream through the alveolar walls. They are poisonous to body tissue or to specific organs. Some metalliferous ores fall into this category. The most hazardous include compounds of arsenic, lead, uranium and other radioactive minerals, mercury, cadmium, selenium, manganese, tungsten, silver and nickel (Walli, 1982)<sup>29</sup>.

- (ii) *Carcinogenic (cancer-causing) dusts:* The cell mutations that can be caused by alpha, beta and gamma radiation from decay of the uranium series make radon daughters the most hazardous of the carcinogenic particles. A combination of abrasion of lung tissue and surface chemical action can result in tumour formation from asbestos fibres and, to a lesser extent, freshly produced quartz particles. Exposure to arsenic dust can also cause cancers. Work is in progress to investigate the potential carcinogenic properties of diesel exhaust particulates.
- (iii) *Fibrogenic dusts:* The scouring action of many dusts causes microscopic scarring of lung tissue. If continued over long periods this can produce a fibrous growth of tissue resulting in loss of lung elasticity and a greatly reduced area for gas exchange. The silica (quartz, chert) and some silicate (asbestos, mica, talc) dusts are the most hazardous of the fibrogenic dusts and may also produce toxic and carcinogenic reactions. Welding fumes and some metalliferous ores produce fibrogenic dusts. Long and excessive exposure to coal dust also gives rise to fibrogenic effects.
- (iv) *Explosive dusts:* These are a concern of safety rather than health. Many organic materials, including coals other than anthracite, become explosive when finely divided at high concentrations in air. Sulphide ores and many metallic dusts are also explosive.

The explosivity of coal dust is well known. These particles become explosive when finely divided, at certain explosion concentration limits, suspended in the air and when a sufficiently strong ignition source is available.

- (v) *Nuisance dusts:* Quite apart from adverse effects on the health of personnel, all dusts can be irritating to the eyes (Gibson and Vincent, 1980<sup>26</sup>), nose and throat, and when sufficiently highly concentrated, may cause reduced visibility. Some dusts have no well-defined effects on health but remain in the category of a nuisance dust. These include the evaporites (halite, potash, gypsum) and limestones. The soluble salts of halite (NaCl) and potash (KCl) can occasionally cause skin irritations, particularly around hatbands or tightly fitting dust masks.

## 2.3 Effects of Dust

The effect of dust on the human exposed to it and the working environment in which such exposure takes place is addressed in this part.

As stated in the introduction, the potential effects of dust depend on its characteristics, such as toxicity, particle size, concentration in the air and, in the case of worker exposure, the duration of such exposure. Coal dust adversely affects the health and safety of workers and the production environment.

### 2.3.1 Effects on health

The effect of dust on the health of workers is determined by its toxicity which can result in a lung disease when it is inhaled. Although coal produces a low biological response it can cause the build-up of realigned dusts in the form of soft plaques within the lung tissue. The prolonged exposure of workers to high coal-dust can lead to the

development of Coal Workers Pneumoconiosis (CWP) or Black lung as it is known in the United States of America.

Diseases of the upper respiratory tract, such as bronchitis or laryngitis may be caused or aggravated by the coarser or inhalable dusts which settle in the upper respiratory tract.

It is well known that the prevalence and severity of CWP differs markedly between different regions and mines despite comparable exposures to respirable dust.<sup>5</sup> This indicates that the difference in the characteristics of different coal dusts causes different health risks.

The possibility of a worker developing CWP from inhaled coal dust is determined by various dust properties and factors. Those identified are:

- Quartz content
- Rank of the coal
- Mineral composition
- Trace elements
- Carbon centred free radical concentration in the coal dust which in turn depend on the freshness of the dust, particle size and rank.

Other factors that play an important role in the development of CWP include:

- Particle size
- Dust concentration
- Worker exposure time<sup>5</sup>

#### (a) Quartz content

Respirable quartz can cause silicosis, respirable asbestos - asbestosis, coal dust - anthracosis (CWP). The common name for all lung diseases caused by inhaled respirable dust is pneumoconiosis. The Occupational Diseases in Mines and Works Act<sup>6</sup> defines pneumoconiosis as "a permanent lesion of the cardio-respiratory organs caused by the inhalation of dust in the course of the performance of risk work."

The presence of quartz in the respirable fraction of dust increases in the probability of workers developing CWP. Quartz particles in the size range 0,5 to 2  $\mu\text{m}$  are of great importance in the development of lung diseases.<sup>7</sup>

It is further suggested that the following characteristics of quartz dust plays a major role in the development of lung diseases:

- particle size
- shape
- surface charge



- roughness
- surface chemical composition
- trace metal content
- crystallinity.

Other factors that have been found to relate to the development of lung diseases in correlation with quartz dust include:

- age of dust
- amount of silica in the ambient air
- duration of exposure
- generic susceptibility
- personal respiratory patterns
- the presence of any co-existing disease (e.g. tuberculosis). <sup>7,8,9,10,11</sup>

#### **(b) Rank of the coal**

A clear relationship between the rank of coal and the incidence of CWP has been demonstrated by researchers in Britain, West Germany and the United States. Other researchers believe that the causal factor may be some variable correlated with the rank of coal rather than the rank itself.

#### **(c) Mineral composition**

Little is known about the effect of mineral constituents on the development of CWP.

#### **(d) Trace elements**

According to recent research in the United States of America, there is a possibility that trace elements contribute to the development of CWP.

#### **(e) Carbon-centred free radicals**

Coal-based free radicals have been detected in the lung tissue of coal workers and the radical concentration was found to correlate with the severity of the disease. The effect which free radicals have on the development of CWP is time-dependent, as freshly grounded dust shows greater chemical activity than aged dust.

#### **(f) Particle size**

The particle size, concentration, and exposure time have been studied extensively throughout the world. As early as 1912 the first dust legislation for mine dusts were formulated when the Union of South Africa introduced laws governing working conditions in gold mines. In 1950 both Europe and the United States proved that workers in bituminous coal mines could attract CWP. In 1959 at the International Pneumoconiosis Conference held in Johannesburg, South Africa, it was recognised that particles of equivalent diameter of less than  $5\ \mu\text{m}$  were most likely to be retained in the lungs.

Particle size and shape determine whether such particles will reach the lung or upper respiratory tract and, together with the toxicity and the period of exposure, will determine the effect on a worker's health.

Medical researchers found that the mean size of dust recovered from the lungs of deceased coal miners is about  $1\ \mu\text{m}$ . They concluded that it is mostly the  $< 5\ \mu\text{m}$  fraction of the respirable dust that is harmful to health; and in particular particles smaller than  $3\ \mu\text{m}$  which tends to accumulate in the lungs.<sup>12</sup>

From a health point of view the particle size, distribution, and mass concentration determine:

- the overall retention of particles
- locations where particles would be deposited
- the rate of growth of the disease in the respiratory system.

#### (g) Dust concentration

The greater the amount (dust mass concentration) of airborne respirable dust in the working environment, the greater the chance of workers developing CWP. Thus the mass of the respirable dust in the working place is an important causal variable in the development of CWP.

#### (h) Exposure time

The exposure time of workers to a dusty environment is another contributing factor in determining the possibility of CWP developing.

CWP is a time-dependent disease. Studies indicate that the longer the time that workers are exposed to respirable dust, the greater the risk of CWP developing.

### 2.3.2 Effects on safety

Apart from the effect that high airborne dust concentrations have on the health of workers, it can lead to reduced visibility in the workplace, and the nuisance value of such concentrations should not be underestimated. The combination of reduced visibility and nuisance value can lead to dangerous work situations developing which

can result in damage to equipment and injuries to workmen.

### 2.3.3 Effects on productivity

The productivity of continuous heading machines is also adversely effected when visibility in the face area decreases. This is especially true during the sumping operation where the operator needs to determine the depth of the cut.

### 2.3.4 Explosions

The impact of dust suppression in the prevention of coal dust explosions is based on two areas. The first is to prevent enough coal dust particles from becoming airborne to create explosive concentrations and to prevent particles from being deposited in the face area and the return airways. In close relationship to this is the amount of inert material (stone dust) required to inert these explosive concentrations. It can, as such, be concluded that if less dust is generated and distributed, the explosion risk and consequently the cost of stone dusting practice can be lessened.

The basic conditions for any dust explosion to take place are: Dust particles of a small size in a cloud spaced far enough apart to have access to sufficient oxygen for complete combustion, but close enough for the heat produced by one particle to support the combustion of the next particle and so on.<sup>13</sup>

For a coal dust explosion to take place the following sequence of events needs to be realised: An ignition source is required, igniting an explosive methane/air mixture (5 - 15 %), if the methane explosion can create enough wind pressure in the initial explosion coal dust particles which were deposited as float coal, will be distributed creating an explosive coal dust concentration, this being ignited and a coal dust explosion will develop, refuelling itself until stopped by protective measures or if no fuel is left.

The primary ignition source for a coal dust explosion is a methane explosion. The violence of a coal dust explosion (strength) is a function of the strength of the methane explosion i.e. the initiating explosion if the same basic conditions exist (eg. coal dust concentrations etc.).

The dust particles that will participate in coal dust explosions must be smaller than 240  $\mu\text{m}$  and a minimum dust concentration of approximately 50  $\text{g}/\text{m}^3$  must be present. The most violent explosions take place when coal dust concentrations of 150 to 350  $\text{g}/\text{m}^3$  are present.

## 2.4 Sources of Dust

Dust generating sources have been identified. This knowledge is of utmost importance as dust prevention of these dust generating sources must be focused on. It is important that people in the working environment be able to identify dust or potential dust creating sources

The breaking of solid material during the mining process, such as coal or stone, will create a certain amount of fine particles, including particles smaller than 100  $\mu\text{m}$ ,

which is defined as dust.

In the breaking process of material the energy input required to break the rock is proportional to the new surface area produced. If excessive amounts of dust is generated it can be concluded that the breaking process or mechanism inefficiently uses energy. This is only partly true for dynamic cutting process where dust is created from secondary comminution processes.

The mechanism of fine fragment formation by mechanised coal cutting involves four steps: Development of a crush zone under the tool tip, macrocrack propagation, shear movement along macrocrack propagation, and additional fragmentation from shearing.

Thus the fundamental mechanism of the primary comminution process (cutting) by which dust is formed can be summarised as:

- (i) crushing, grinding and scraping by the tool bit,
- (ii) energy dissipation in the fracture process zone, and
- (iii) explosive disintegration of stored elastic strain energy.<sup>14</sup>

In addition to the primary comminution process, secondary comminution can take place at various places e.g. in the cutting cycle or in the handling and transport of the coal. When coal is cut with a continuous miner, the coal removed by the top picks which moves through the drum arch and secondary grinding, crushing and the re-entrainment of dust particles which increases the dust generation.

The impact of falling coal (be it in cutting or off loading during transport) results in further comminution and entrainment of the dust adhering to larger particles. It can be concluded that the three major sources of secondary dust formation during cutting are: grinding, falling and gathering<sup>15</sup>

Studies in the United States<sup>16</sup> showed that only about 0,01 % of respirable dust generated is released into the air. The other 99,99 per cent adheres to the larger fragments of the coal.

Workers are exposed to dust that is primarily formed in the face and in addition to dust that may reach the work area in the intake air. Intake air generally contains dust that is generated by operations outbye of the face area.

#### 2.4.1 Sources outbye of the face

The primary areas of dust generation and re-entrainment of dust outbye of the face area are conveyor belts, coal haulage transfer points, and haulage roads.

Dust adhering to the surface of the conveyor belt can be re-entrained into the air by the vibration of the belt as it passes over the belt rollers. Dust adhering to the bottom belt, when returning, can be crushed and pulverized creating a significant source of respirable dust. However, it is not thought to be a significant source of quartz dust due to the elastic properties of the belt and the durable nature of quartz. The use of water at various positions should be moderate, as it can wash particles adhering to the larger coal fragments clean. These particles can then adhere to the belt and if not cleaned by scraper devices can then be deposited in the beltway below the conveyor.

Coal-transfer points generate dust by secondary comminution and re-entrainment of

dust adhering to larger coal particles. Coal-transfer points include feeder breaker to belt, stage loader to belt, belt to belt, belt to transfer chutes, and belt to silos.

Where feeder breakers are used for secondary breaking, further dust will be generated by the comminution process. Although this is generally not a problem, the potential for the generation of large amounts of dust exists when a large quantity of large rocks has to be crushed over a period of time.

During the transporting process coal should be kept damp. It is advisable to enclose the transfer points and if possible to extract the dust laden air into return airways. The use of sprays bars onto conveyors some 10 - 20 m before a transfer point are often more effective than sprays at transfer points.<sup>30</sup>

Dust dispersed from haulage roads is generally in the respirable range due to secondary crushing and pulverisation of the coal by the tyres travelling over it. Dust generated in this manner is normally of lesser importance, but studies by Mutmansky<sup>17</sup> have indicated that a significant amount of respirable dust can be generated by this process.

The dust generated in the transport roadways of a mine can be problematic as most of these roadways are situated in the fresh air intake. The finer dust particles re-entrained into the air will most probably travel throughout the section and mine. The coarser particles may settle out (be deposited) but the crushing and pulverization of these particles through the vehicle tyres will ensure a significant dust source in the intake air unless treated with some kind of binding agent.

## 2.4.2 Conventional mechanised mining

In conventional mining all the face production activities are dust sources. It is of importance to note that roofdrilling for support can also be a major source of quartz dust if no dust suppression is done (wet drilling or dust extraction system).

The dust sources are:

- Coal cutting
- face drilling
- blasting
- loading
- transport
- roof drilling (support).

Coal cutting and drilling are the two highest dust generating sources. The respirable dust generated by these processes is less than the respirable dust generated during continuous mining operations. This is due to the fact that the operating time in an entry is short, resulting in low full-shift personal dust exposures.

The blasting of the coal face results in a short period of high dust concentrations. As personnel are removed from the explosion site, only returning once the face area is cleaned from dust and harmful gases, by the ventilating air, the exposure to dust created and entrained should be limited.

Wetting of the muckpile should further reduce re-entrainment of dust during the loading and transport of the broken coal.

Studies undertaken by Organichak et al, have indicated that quartz dust produced by this mining method can be less than the other mining methods if good horizon control is exercised.<sup>18</sup>

### 2.4.3 Mechanical miner mining

In a mechanical miner (MM) section the major source of dust is the MM when cutting coal. Three mechanisms of coal dust formation by the MM can be identified, namely; the primary comminution, secondary comminution and re-entrainment of dust.

The dust sources are:

- Coal cutting
- transport
- roof drilling (support).

Previous studies by Chiang have also shown that cutting rock (roof or floor) can contribute five times the respirable dust when compared to cutting coal. Control of cutting horizons is thus essential.<sup>19</sup>

The primary communication process is when the coal is cut by the pick point, this broken chip is then rotated through a certain angle before being freed from the secondary drum comminution process. It is then free to fall from different heights colliding with other chips (re-entrainment and comminution) causing secondary breaking and again re-entrainment.

Wherever coal is handled, subsequently, in the transport process dust is dispersed (re-entrained) into the air. Dust is dispersed at the loading point on the mechanical miner (gathering arms), the transfer point from the mechanical miner to the shuttle car, the feeder breaker (shuttle car offloading and fragment breaking), belt loading point and all subsequent belt transfer points.

The dust created during roof drilling operations for support can be a significant dust source. The suppression methods, wet drilling or dry extraction systems, are effective means of suppressing this dust if used correctly.

### 2.4.4 Longwall mining

In longwall mining the major source of dust is the shearer and, to a lesser extent, the movement of roof supports

The major sources of dust have been identified as:

- shearing process
- roof support (shields) movement

- armoured face conveyor(AFC)
- stage loader
- the goafing of the worked out area.

The amount of dust produced by the shearer depends on the seam conditions, the operational parameters and the types of internal and external water sprays in operation.

The amount of airborne dust generated by the support advance depends on the immediate roof conditions, and it varies with the support advancing operation, and the setting and yielding loads of the supports. As the setting and yielding loads increase, greater amounts of dust are generated.

Airborne dust generated by the AFC and/or belt transportation is limited and depends on the length of the conveyor. Studies in the United States indicated that between 0,1 and 0,3 mg/m<sup>3</sup> of dust was generated by the face conveyor.<sup>19,20</sup>

Dust dispersed into the air from a roof fall in the goaf area is dependent on the size of the fall. If the goaf position is relatively close to the face, (small goaf) the amount of dust generated and entrained will be less than if a large goaf takes place resulting in a large volume displacement and energy release.

## 2.5 Behaviour of Dust

The behaviour of dust in the ventilation system of a mine is a complex system of different phenomena acting on different sized dust particles. The size range of dusts present result in a completely different behaviours inside the same aerosol. The smaller dust particles will behave as a gas, and will be primarily influenced by molecular forces, while the larger dust particles will be primarily influenced by inertial and gravitational forces.

### 2.5.1 Aerodynamic movement of dust

The movement of dust particles in a ventilating airstream is complex. The predominant mechanisms for deposition of dust particles are gravitational settlement, Brownian motion, eddy diffusion and coagulation of dust particles. Each of these mechanisms will be dealt with briefly.

#### (a) Gravitational settlement

The gravitational force exerted on a dust particle will tend to let the dust settle towards the floor. The gravitational settling velocity depends mainly on the size, shape (mass and volume), and density of the particles.

The Stokes law is frequently used to describe gravitational settlement. The simplest form of this law is shown in Figure 2.

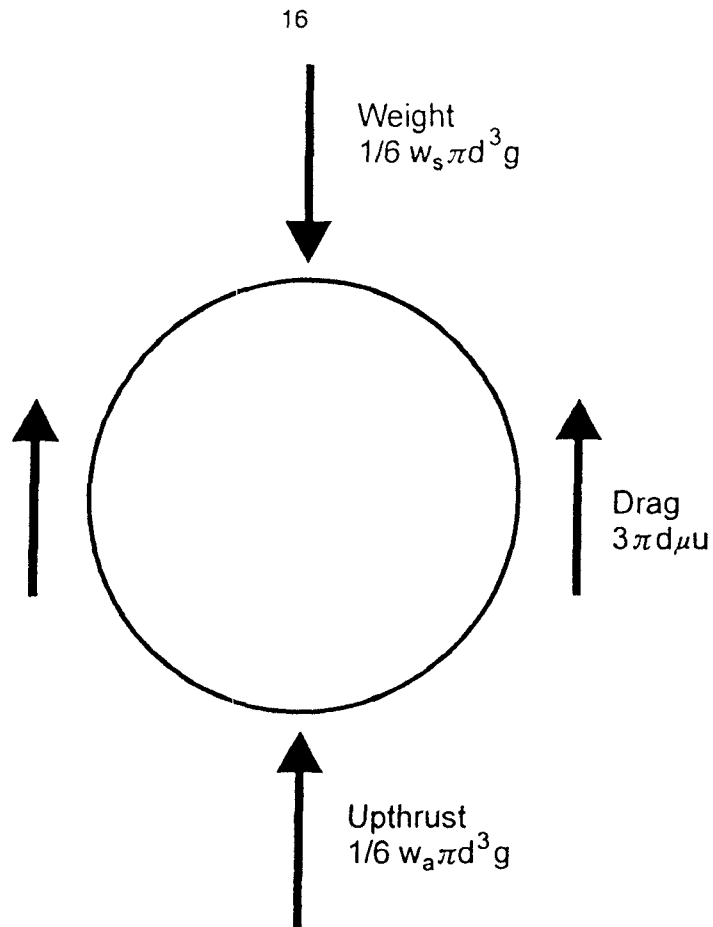

Figure 2.2 Forces acting on a dust particle

This shows a particle trying to settle under its own weight and experiencing an upthrust which is equal to the displacement of the weight of the air and drag resistance due to viscous shear and turbulent eddies.

As the particle accelerates downward equilibrium is reached when:

$$\frac{1}{6} \pi d^3 g (w_s - w_a) = 3 \pi \mu_a u d \quad [N] \quad (1)$$

where  $d$  = particles diameter [m]  
 $g$  = gravitational acceleration [ $m/s^2$ ]  
 $w_s$  = density of sphere [ $kg/m^3$ ]  
 $w_a$  = density of fluid [ $kg/m^3$ ]  
 $\mu_a$  = dynamic viscosity of the fluid [ $Ns/m^2$ ]  
 $u$  = relative velocity ( $u_s - u_a$ ) [m/s]

At the point of dynamic equilibrium the settling velocity becomes constant and is



called the terminal settling velocity ( $u_t$ ). The equation for terminal settling velocity is:

$$u_t = \frac{d^2 g (w_s - w_a)}{18 \mu_a} \quad [m/s] \quad (2)$$

In still air the terminal settling velocity is reached quickly. The terminal settling velocity increases rapidly with particle size being proportional to the square of the particle diameter.

The Stokes law applies well to particles that are above the respirable size range ( $> 6 \mu m$ ). A more general and usable form of the terminal settling velocity for larger particles is given by:

$$u_t = \sqrt{\frac{4}{3} \frac{dg (w_s - w_a)}{c_d w_a}} \quad [m/s] \quad (3)$$

Flagan and Seinfeld<sup>31</sup> suggests the following approximations for the coefficient of drag ( $C_d$ ). This is shown in the following table.

**TABLE 1**  
**APPROXIMATIONS OF THE COEFFICIENT OF DRAG FOR SPHERICAL**  
**PARTICLES**  
(after Flagan and Seinfeld, 1988)<sup>31</sup>

--

"Table 20.1" and the Reynolds number (Re) can be calculated from

$$Re = \frac{w_a d u_t}{\mu_a} \quad (4)$$

The Stokes law applies to particles that are relatively large to the mean free path of a particle. The mean free path of a particle is defined as the average distance a particle will move between colliding with another particle. Thus for smaller particles a slip correction factor is defined to reduce the value of drag.

The slip correction factor ( $C_c$ ) can be determined by the following equation:

$$C_c = \frac{9,56 \times 10^{-8}}{d^{1,045}} + 0,99 \quad (5)$$

with  $d$  in metres to within a 2 % accuracy.

This can now be incorporated into equation 2 and will give a good relationship for particles as small as  $0,01 \mu\text{m}$  where:

$$u_t = \frac{d^2 g (w_s - w_a) C_c}{18 \mu_a} \quad (6)$$

To combine the above knowledge into an unit the following calculated example is given:

**Example:** Determine the terminal settling velocities and time taken for deposition of dust generated at the roof position (3,0 m high) in a mechanical miner section for particles having a geometric equivalent diameter of 0,1; 1; 5 and  $20 \mu\text{m}$ . The air density is  $1,0 \text{ kg/m}^3$ , the dynamic viscosity  $\mu_a = 18 \times 10^{-6} \text{ Ns/m}^2$  and the density of the dust particles is  $1100 \text{ kg/m}^3$  (still air).

**Solution:** The general form of equation 6 is:

$$u_t = \frac{d^2 g (w_s - w_a) C_c}{18 \mu_a}$$

$$= \frac{9,81 (1100 - 1) d^2 C_c}{18 \times 18 \times 10^{-6}}$$

$$= 3,328 \cdot 10^7 d^2 C_c$$

Cc can be calculated from equation 5:

$$C_c = \frac{9,56 \times 10^{-8}}{d^{1,045}} \cdot 0,99$$

$$= \frac{9,56 \times 10^{-8}}{(0,1 \times 10^{-6})^{1,045}} \cdot 0,99$$

$$= 2,96$$

$$u_t = 3,328 \times 10^7 (0,1 \times 10^{-6})^2 \times 2,96$$

$$= 0,99 \times 10^{-6} \text{ m/s}$$

$$\text{Time} = \text{Height}/u_t = 3/0,99 = 844 \text{ h}$$

A summary of the results are shown in table 2.

**TABLE 2**  
**RESULTS**

d (μm)	0,1	1	5	20
Cc	2,96	1,168	1,023	1
u <sub>t</sub> (m/s)	0,99 × 10 <sup>-6</sup>	3,89 × 10 <sup>-5</sup>	8,51 × 10 <sup>-4</sup>	0,01
Time	844 h	21,4 h	5,9 min	3 min 45 sec

The above results re-iterate the effect of coarser particles settling more quickly and fine dust particles staying suspended in the air stream for considerable time.

There are a number of forces acting on dust once it has become airborne. Uniform (steady, straight line) motion is the result of the action of a constant external force such as gravity and the resistance of air to the movement of the particle. The resisting force of air depends on the relative velocity of particle and air.

Unfortunately airborne dust does not only undergo uniform movement. Dust particles tend to follow curvilinear motion around obstacles. This is when a particle follows a curved path. In uniformly moving air this motion will be the result of the acceleration of the particle in one direction or the variation with time or position of one of the forces acting on the particle. It can also be the result when flowing air passes an obstacle or changes direction resulting in curved streamlines and causing suspended

particles to have curvilinear motion.

### **(b) Brownian motion**

Particles suspended in air are subject to Brownian motion. Brownian motion is the irregular motion of a dust particle in still air that is caused by random variations in the incessant bombardment of air molecules against the particle. At any moment the direction in which the particle is moving can be altered. It can thus be said that the particle undergoes a wandering or jerky motion.

As the particle size decreases the importance of brownian displacement increases. This size falls between 0,2 and 0,6  $\mu\text{m}$  depending on the density of the particle. At these smaller diameters the importance of gravitational settlement decreases and can be nullified.

The movement of dust particles by Brownian motion and diffusion is dependent on the diffusion coefficient(D). The higher the particle diffusion coefficient the more vigorous the Brownian motion and the more rapid the diffusion process.

Another important aspect in particle motion is the mean free path of the particle. The mean free path is defined as the average distance travelled by a molecule between successive collisions. The mean free path of a particle thus influences both diffusion and Brownian motion.

Brownian motion leads to brownian diffusion of particles. Diffusion is defined as the mass transfer of particulate matter through a gas in the absence of fluid flow or the diffusion of aerosol particles is the net transport of these particles in a concentration gradient. The movement of dust particles by this motion is the greatest when the particles are small (less than 0.1 micrometre).

### **(c) Eddy diffusion**

In the ventilating air in the underground ventilation system the turbulence of the air is another important action on the dust particles. Eddy diffusion is a direct result of the turbulence. This phenomena gives rise to the dust particles moving across streamlines, from turbulent flow to laminar flow. Thus the eddy action can create enough inertia on a dust particle to alter its flow direction into laminar sublayers where no eddies are found. This action is similar to fluid flow through pipes and is influenced by fluid density, viscosity, velocity and the roughness of the sidewalls.

The shape of the particle influences the settling rate. Except for certain streamlined shapes, nonspherical particles settle more slowly than their equivalent volume spheres.

At the same time the position of the particle relative to the floor and sidewall and the air movement pattern will determine the distance that each particle will move away from the dust source before settling.

### **(d) Coagulation**

One way for dust to settle more quickly is by agglomeration, better known as

coagulation, as a result of particles colliding with each other and adhering to another thus creating bigger and heavier particles. These collisions are a direct result of Brownian motion, eddy action and the difference in gravitational settlement. The influence on the dust mass concentration is that the number of smaller particles decreases and the settling rate increases.

The rate of coagulation is influenced by number and size distribution of the particles, temperature and pressure of the air, electrical charge distribution, particle shape and the presence of absorbed vapour on their surfaces.

The coagulation process takes place because the adhesive forces on micrometre-sized particles exceed other common forces by orders of magnitude. The particles can gain an electrical charge during formation or induced electrical charge due to frictional airflow effect. Uncharged particles may gain dipole characteristics due to van der Waals forces acting upon them.

The main adhesive forces are van der Waals force, electrostatic force and the surface tension of adsorbed liquid films, with these forces tending to increase the rate of coagulation.

### **(e) Impingement and re-entrainment**

Impingement of particles onto surfaces is the net result of particles impacting onto surfaces. The impaction action is a net result of particles, due to the inertia of the particle, at higher velocities being unable to pass an object and thus crossing streamlines and impacting onto a surface and adhering to it.

At higher velocities the particles can bounce off the surface, without adhering to it, and can be re-entrained into the air stream. This bounce off effect can also be the result of viscous drag, when high velocity gradients exist close to the surface where the particle adheres to, and thus drag the particle across the sublayer and re-entraining it.

The impingement - re-entrainment action is of importance in the face area where turbulence and complex air flow patterns exist. The re-entrainment of dust particles is influenced by whether the surface is wet or dry, the pick-up velocity (function of particle size), and the drag and frictional forces acting in a dust particle on, or very close to, solid surfaces.

## **2.5.2 Spatial distribution of dust**

The spatial distribution of dust in the underground mining environment is influenced by various aspects. Many of these, such as particle size and shape, airflow velocity etc., have been dealt with in detail in the preceding paragraphs. Only limited results obtained during measurement of spatial distribution is recorded.

The rate of decrease in the concentration of respirable dust is the highest in the first 60m from the source. From 60 m to 300 m there is a significantly lower deposition rate and beyond 300 m there is virtually no change. This phenomenon is a direct result of the coarser particles settling more quickly than finer particles and the net result is that particles in the size range 3-7  $\mu\text{m}$  are carried through the mine.

The larger particles are deposited first, while the smaller particles tend to settle out later. Dust particles in the respirable size range are likely to be transported through the whole working area.<sup>21,22</sup>

The ratio of the respirable fraction of the airborne dust increases with distance from the source.<sup>23</sup> This is due to the lower deposition rate for smaller sized particles increasing the number of smaller particles relative to the larger particles in the airborne dust.

A Study by the Pennsylvania State University indicated that the highest concentration of Quartz is in the size range from 0,6 to 3,5  $\mu\text{m}$  with less quartz in the 3,5 to 10  $\mu\text{m}$  range and even less in the 10 to 21  $\mu\text{m}$  range.<sup>19,24</sup>

### 2.5.3 Time related occurrence of dust

The amount of airborne dust varies with the activity that generates the dust. This can be illustrated by the continuous miner cutting sequence. During sumping more fine particles are generated than during the actual cutting of the face. This is the result of excessive grinding and crushing of the coal fragments in a confined space during the sumping process. It is also known that different mining methods create different dust loads.

Movement of the dust source itself can give rise to different dust concentrations found in the face. This can be illustrated by the difference in the concentration of airborne dust, depending on the direction that the shearer cuts in relation to the ventilation direction, in a longwall face.

As the ventilating air carries the airborne dust away from the source, such dust will be present in the form of "plugs" or clouds of dust, although a certain amount of dilution will occur as a result of turbulence and air mixing.

A higher dust generation rate results in higher airborne dust concentrations, and the rate of increase of the airborne dust concentration is higher than that of the dust generation rate.

### 2.5.4 Air movement and dust

Air movement is one of the most important forces acting on dust in mines, because it is the means by which dust is diluted and removed from the working areas to protect the health and safety of the workers.

Dilution of dust particles is the result of the greater volume of air available to dilute the dust mass concentration.

Dust movement by the ventilation air is dependent on the amount of ventilation air available (quantity) and the airflow velocity. An increase in ventilation flow tends to reduce airborne dust concentration, unless the airflow velocity is high enough to re-entrain settled dust particles

The threshold velocities for the pick up of Quartz and coal dust particles for different size ranges are shown in Table 3<sup>25</sup>

TABLE 3  
PICK-UP VELOCITIES FOR COAL AND QUARTZ PARTICLES

	Particle Size (micrometre)	Pick-up (m/s)	
		Quartz	Coal
<b>Dry</b>	75 - 105	6,3	5,3
	35 - 75	5,3	4,2
	10 - 35	3,1	3,2
<b>Semi dry</b>	75 - 105	7,4	6,3
	35 - 75	6,3	5,3
	10 - 35	4,2	4,2

### **3 A STRATEGY TO REDUCE WORKER EXPOSURE TO DUST**

3.1	Introduction	24
3.2	Minimize Make of Dust	24
3.2.1	Know the amount of dust that is made by the process	24
3.2.2	Increase the coal size distribution of the coal breaking process	25
3.2.3	Minimize the secondary comminution aspects in coal breaking process	25
3.2.4	Minimize the secondary/tertiary comminution during the coal transport process	25
3.2.5	Minimize the amount of quartz in the make of dust	25
3.3	Minimize the Liberation of Dust	25
3.3.1	Capture or contain dust within the coal mass	26
3.3.2	Keep dust within coal mass during the loading and transport process	26
3.3.3	Minimize energy transfer into the coal dust mix	26
3.3.4	Keep dust contained where it is through agglomeration and cohesion processes	26
3.3.5	Contain areas where dust is, or has been liberated	26
3.4	Reduce the Amount of Liberated Dust in the Air	27
3.4.1	The distribution of the liberated dust should be known	27
3.4.2	Knocking the dust down	27
3.4.3	Scrubbing the dust out of the air	27
3.4.4	Removing or extracting the dust laden air from the worker area	27
3.4.5	Dilution of dust concentration	28
3.4.6	Filter the dust from the air	28
3.5	Remove Worker from Dust Laden Air	28
3.5.1	The spatial distribution of the dust must be known	28
3.5.2	Air moving mechanism to take dust laden air away from the worker positions	28
3.5.3	Remove worker from high dust areas by physically placing him in a safer area	29
3.5.4	Lower the exposure to dust by letting the worker work shorter periods in the high risk areas	29
3.6	Placing Barriers between Worker and Dust Laden Air	29
3.6.1	Physical barriers to the dust	29
3.6.2	Filters mechanisms	29
3.6.3	Air curtaining	29
3.7	Ensuring that Systems Work	30
3.7.1	The right choice of system has to be made	30
3.7.2	The system has to be installed in the underground environment	30
3.7.3	The system has to be maintained to work at maximum efficiency	30
3.7.4	The efficiency of the system must be regularly controlled	30



## 3 A STRATEGY TO REDUCE WORKER EXPOSURE TO DUST

### 3.1 Introduction

In devising an overall strategy to combat worker exposure to dust the main principle used is that it is easier to contain the dust than to remove the respirable dust from the air. This is because the finer dust particles start to behave more like a gas than an actual dust particle. The more dangerous dust, the very small particle, is thus more difficult to remove, and one of the best ways of reducing their presence in the air is to stop them from getting there.

The strategy is thus devised in steps, from the most fundamental to those that have the most influence on the environment.

The strategy has the following main objectives that it strives for:

- Minimize the amount of dust made (by the mining and other processes)
- Minimize the liberation of dust into the air
- Reduce the amount of liberated dust in the air
- Remove the worker from dust laden air (or the air from him)
- Place a barrier between worker and the dust laden air
- Ensuring that installed systems are working at maximum efficiency for the maximum period of time.

Each of these main objectives can be achieved through the application of different technologies and methods. The use of the technologies and methods are elaborated in the following way.

### 3.2 Minimize Make of Dust

Minimizing the amount of dust made by the mining processes can be accomplished by achieving the following.

#### 3.2.1 Know the amount of dust that is made by the process

To be able to determine if the amount of dust that the mining process makes is acceptable or not, or to determine if any action taken to reduce the make of dust is working, the amount of dust made by the system has to be known. As the amount of air flowing over the system has an effect on the amount of dust in the air, any changes in the airflow would thus have an effect on the amount of dust measured by any normal dust measuring instrument. This means that these instruments cannot be used to determine the amount of dust made, and a system where the actual size of the mining product is determined has to be used.

### **3.2.2 Increase the coal size distribution of the coal breaking process**

In considering the various theories relating to the way that materials break, it is found that there is a distinct relationship between the various sizes for a given material like coal. This means that if coal should be broken by a process, the various sizes will always be in a specific relationship to each other. This poses the problem that, if this is so, there is not really much one can do to reduce the amount of fine made when breaking a material. The value of changing the size lies in the unit amounts of fine dust made per unit mass of the product. If the top size of the coal is only one ten millimetres, then a greater proportion of dust in the form of very fine coal will be made for a ton of coal, than when the top size of the coal is, say, a hundred millimetres. Unfortunately large pieces of coal giving a low proportion of dust does not lend itself to being transported on conveyor belts. To cater for the crushing of coal, use must be made of differentiated procedures that only address the larger coal sizes and does not subject the whole coal mix to a crushing process.

### **3.2.3 Minimize the secondary comminution aspects in coal breaking process**

The secondary comminution, or breaking of coal, contributes significantly to the making of fine coal particles and efforts must be directed at reducing this. The efforts that have gone into reducing the amount of dust per unit of coal product can be completely eradicated if attention is not paid to reducing the secondary comminution processes.

### **3.2.4 Minimize the secondary/tertiary comminution during the coal transport process**

The tertiary comminution processes which occur when the coal is transported by means of conveyor and other means, can subject small amounts of coal to grinding processes. These processes can pollute the intake air which means the intake air is already polluted with an unacceptable amount of dust.

### **3.2.5 Minimize the amount of quartz in the make of dust**

As the amount of quartz in the dust is a major determinant of how dangerous the dust is, any process that leads to quartz being liberated, like cutting into a sandstone roof or floor, can seriously increase the danger to workers. Even though acceptable gravimetric readings can be obtained, the amount of quartz in these readings could make the exposure completely unacceptable

## **3.3 Minimize the Liberation of Dust**

If efforts directed at reducing the make of dust in the coal mix have been taken to the optimum then the next step would be to reduce the amount of the dust, that has been

made, from becoming liberated in the air. This can be achieved by the following set of actions.

### **3.3.1 Capture or contain dust within the coal mass**

The first effort in minimizing the dust release is to capture the dust or contain it in the mix. The very nature of the broken coal mix allows the smaller particles to be contained within the matrix wherein there are significant larger pieces. The smaller particles also adhere to these larger pieces. The use of water sprays or processes that do not spread this mix around will contribute to containing the dust.

### **3.3.2 Keep dust within coal mass during the loading and transport process**

In the process of transporting the coal from the face it has to undergo various transfer processes. The transfer process, like loading of coal on the shuttlecar, loading the coal on the conveyor or transferring the coal between belts, can be such that the coal mix is either dispersed or contained. If the coal falls through a long distance the propensity for releasing dust is greater than when the coal undergoes a gentle transition.

### **3.3.3 Minimize energy transfer into the coal dust mix**

To release a particle from the coal mix, energy is required to break the natural adhesion between the particle. A stream of air flowing over or through the coal will rip the particles loose if the force that the air current transmits to the particle is greater than the force between the particles holding them together. This energy can be in the form of air currents, or water jets or sprays, or mechanical energy. The source could be the continuous miner or the material falling through a distance.

### **3.3.4 Keep dust contained where it is through agglomeration and cohesion processes**

If the cohesion between particles in the mix can be increased then more energy will be required to actually loosen a dust particle from the mix. The use of water or surfactants which breaks down surface tension of the water greatly increases the agglomeration and inter-particle adhesion in the coal mix

### **3.3.5 Contain areas where dust is, or has been liberated**

If the necessary process being used is such that it liberates dust into the atmosphere, and all reasonable methods cannot keep the dust in the mix, then the only recourse is to isolate this so that the dust does not get into the general environment. Typical examples

of this are containment of crusher points or the sealing off of bunker transfer points.

### **3.4 Reduce the Amount of Liberated Dust in the Air**

When the previous activities have not rendered the required results, and in practice they seldom do, then the next recourse to keep the environment in a suitable condition is to remove sufficient dust from the air thereby achieve acceptable levels. By taking the following actions this can be achieved.

#### **3.4.1 The distribution of the liberated dust should be known**

Before any action is taken to remove dust from the air the distribution of the dust in the air must be known. This is necessary so that the methods used to remove the dust from the air can be focused at these points. One of the known aspects that influence the combatting of dust is that the time occurrence of dust is not a single value over the shift, but rather a low number of high short time period occurrences and a high number of low value occurrences.

#### **3.4.2 Knocking the dust down**

The almost universal and most cost effective method of reducing dust in the air is to knock it down with water-sprays and other methods like foams. These materials collect the dust within themselves and when dropping down, take the dust with them

#### **3.4.3 Scrubbing the dust out of the air**

The next step in removing the dust from the air is to scrub it out. i.e. the air carrying dust is taken through the scrubbing mechanism, where the dust is collected and cleaned or the partially clean air is released from the mechanism.

#### **3.4.4 Removing or extracting the dust laden air from the worker area**

Removal of the air from the worker area is achieved by using air movers that contain the dust ( in an exhaust duct) and then transport it to a place where it can be safely released or treated further. This removal of the dust has a secondary effect in that it can also work as a method of bringing fresh air into the heading. The efficiency of the system to capture the dust laden air becomes of prime importance in ensuring that this method brings about the desired results

### **3.4.5 Dilution of the dust concentration**

Although it is often used to address the dust problem dilution of dust is not achieved by increasing the amount of air to the problem area. On the one hand an increased flow of air can cause more dust to be released which increases the dust levels. Even if there is no increased dust release there can still not be dilution unless there is actual mechanical mixing. As respirable dust tends to act like a gas, especially in faster airflows, the air speed only tends to move the dust along at a greater speed without actually reducing the concentration.

### **3.4.6 Filter the dust from the air**

In this activity the dust laden air can be passed through a filter that contains the dust while letting the air through. This principle is not practical in the underground heading but the principle that is being used is when issuing face masks to operators to reduce their exposure to thoracic dust.

## **3.5 Remove Worker from Dust Laden Air**

When all the efforts directed at removing the dust out of the atmosphere where workers work have not given the desired results the next step is to remove the worker from the dust laden air. This is also the principle for the simplest, yet most successful, of all activities to reduce the exposure of workers. By keeping workers subjected to intake air, ventilating for methane and removing the dust out of the heading, the most effective system can be achieved.

### **3.5.1 The spatial distribution of the dust must be known**

To be able to take the worker out of the dust the spatial distribution of the dust occurrence must be known so that the worker can be placed in the areas with the lowest chance of exposure. This placement of the workers should not be left up to him, as in the most cases he cannot determine when an area is dangerous or not, simply because dangerous respirable dust cannot be seen by the human eye, especially in badly lighted areas.

### **3.5.2 Air moving mechanism to take dust laden air away from the worker positions**

The ventilation system and the air moving mechanisms in the heading must be such that the dust laden air is taken away from the operator so that he is subjected only to intake air. Any efforts to reduce worker exposure will then revolve around reducing intake air dust levels rather than reducing the dust levels of the air in the heading. This process is the one used on longwalls to keep worker exposure to a minimum.

### **3.5.3 Remove worker from high dust areas by physically placing him in a safer area**

To move the worker away from the high dust area a different method of controlling the machine must be found. By using radio remote control the machine operators can be placed in areas where they are only subjected to intake air and not to the dusty air in the heading. Using this system, and then removing the dust laden air out of the heading means significantly less efforts need to be taken to knock or scrub the dust out of the air.

### **3.5.4 Lower the exposure to dust by letting the worker work shorter periods in the high risk areas**

As exposure to dust of workers is based on shift time, any reduction in the amount of time will reduce his measured exposure. Although it sounds as if this activity could be counter-productive, it is quite an achievable alternative in the event of all efforts not giving the required low exposure levels.

## **3.6 Placing Barriers between Worker and Dust Laden Air**

Although not being the same as physically removing the operator, the end result can be the same. By using air curtains or even air-conditioned types of cabs the worker can be completely isolated from the dusty environment outside of the barriers.

### **3.6.1 Physical barriers to the dust**

Physical barriers to dust can be sealed cabs, or enclosure, where the operator can be isolated from the outside environment.

### **3.6.2 Filters mechanisms**

A filter barrier can be placed between the worker and the dirty air. This might not be practicable for fine respirable dust but could be useful in the event of reducing the thoracic dust.

### **3.6.3 Air curtaining**

Work has been done whereby the physical barriers have been replaced by the use of air curtains to contain the operator in a sealed-off environment. These air curtains can be fitted over the operators cab, but can also be so small that they are only installed over the operators hard hat.

## **3.7 Ensuring that Systems Work**

To ensure that the systems are working at maximum efficiency and for the maximum period of time the following has to be done.

### **3.7.1 The right choice of system has to be made**

Due to the differing situations that are being utilized underground in the heading, the right type of system for the situation has to be installed. The ventilation system, scrubber and other airmovers have to be in balance to achieve the aims set out in the strategy, while still conforming to the other constraints.

### **3.7.2 The system has to be installed in the underground environment**

The chosen system has to be capable of being installed in the underground environment, as well as being capable of doing the work intended in this environment. The chosen system should also be of such a nature that it assists promoting productivity rather than detracting from it.

### **3.7.3 The system has to be maintained to work at maximum efficiency**

As completely maintenance free systems do not exist, as well as the fact that these systems will be working in a harsh environment, maintenance of these systems is an important issue. It does not help if mine management spends large amounts of money on providing systems to keep exposure down and these systems do not function because they have not been maintained or cleaned.

The presence of a system in the underground environment does not necessarily reduce the amount of dust, but a system that works efficiently does.

### **3.7.4 The efficiency of the system must be regularly controlled**

To ensure that the system does what it is intended to do is not only an engineering function but also an environmental responsibility. The right type of testing methods should be used to determine the effectiveness of the various components of the system to ensure that each of the components are functioning correctly, and making the contribution intended.

## MEASUREMENT OF DUST

### 4.1 Introduction

The occurrence of Coal Workers Pneumoconiosis (CWP) in coal mines, commonly known as black lung, has resulted in various regulatory requirements. At the beginning of the century the death toll related to dust exposure resulted in a series of laws governing hard rock mines. In 1950 it was accepted in the USA and Europe that workers in bituminous coal mines could contract CWP.

The dust associated with the development of CWP is accepted as the respirable fraction of airborne particulates based on the "Johannesburg Curve" for size distribution, i.e. particle aerodynamic diameter of less than 7  $\mu\text{m}$  as indicated previously (Figure 2.1, chapter 2).

The occurrence, severity and the other related aspects to the development of CWP is described in greater detail in chapter 2.

### 4.2 Objectives of Measurements

The method of dust measurement is related to the reason for sampling i.e. whether sampling is done for regulatory purposes or to determine a certain aspect, such as the study of the behaviour or properties of dust in the face area. As such it is needed to ensure that the objective of the sampling is met throughout the sampling process.

#### 4.2.1 Legal requirement

The requirement set by the DMEA requires that at least 5 % of persons exposed to harmful pollutants, in the course of their work, must be monitored for a full shift during each six month period. The results must be submitted in a biannual report to the DMEA.

The dust measurements are reported as a time-weighted average (TWA) exposure figure. The Threshold Limit Value Time Weighted Average (TLV-TWA) is specified by the DMEA from time to time but in essence should ensure that all risk workers can be repeatedly exposed to such TLV-TWA for 8 hours per day or 40 hours per week without adverse effect to their health.

The calculation of the various Air Quality Indices (AQI) and the related risk assessment is stipulated by the DMEA.

#### 4.2.2 Compliance testing



### 4.2.3 Engineering sampling

Additional dust measurements are done in areas where regulatory exposure measurements indicate a dust problem. These factors can include such aspects as the various dust sources or the effectiveness of a dust suppression system.

The samples that need to be taken, as well as the type of instruments that should be used, must be carefully considered. The test procedure is designed and determined according to the results that need to be obtained. To achieve a set objective, certain data needs to be acquired. These can include:

- (i) Mine-specific data
- (ii) Air-flow measurements
- (iii) The airborne respirable fraction of dust
- (iv) The total airborne concentration of dust
- (v) The real-time dust concentration

A series of instantaneous dust concentration measurements, better known as real-time dust measurements are taken to determine the dust profile over a time period and if properly analysed can be related to various mining activities and to different dust conditions.

Total and respirable, generated and airborne dust concentrations can be sampled to determine aspects such as size distribution of dust, deposition rates and airborne dust behaviour.

The evaluation of the dust measurements enables the identification of various dust sources and influences such as ventilation flow, air leakage, mining activity and the characteristics of the dust particles.

Furthermore it is necessary to ascertain the mining activities, such as in a longwall face the direction of shearing, shearing cycle, production stops, etc., and to relate them to different dust concentrations on a relative time basis.<sup>1</sup> In addition to this, it is necessary to determine the ventilation profile and to keep an accurate activity log of operations in the underground section.

Based on the knowledge gained from measurements, methods can be devised to improve the dust-control strategy in such a way that workers are only exposed to acceptable dust levels.

## 4.3 Instruments

The instruments described in this part of the chapter are the most widely used instruments in South Africa.

### 4.3.1 Personal gravimetric sampler

A number of gravimetric measuring instruments are in use. They include instruments

which are completely self contained (e.g. CIP 10) and others which include a mini cyclone, filter holder and pump configuration

The Personal Gravimetric Sampler is designed to only capture airborne dust in the respirable range, i.e. according to the Johannesburg curve. For regulatory sampling the sampling instrument must be approved by the DMEA to ensure compatibility.

### (a) Rotating high volume cassette sampler

This instrument is a small compact personal dust sampler.

#### *Principle of operation*

A small rotating cassette (7 000 rpm) draws the dust-laden air through the instrument. The rotating cassette contains an open all polyurethane foal filter which collects the dust particles. The dust measurement is obtained from the the dust sampling and analysis procedure as described by the DMEA.<sup>6</sup>

### (b) Mini cyclone and filter gravimetric sampler

#### *Principle of operation*

To ensure that only respirable dust is collected, the personal gravimetric sampler of the cyclone and filter type incorporates a mini-cyclone size selector, so that only respirable particles smaller than 7 µm pass through to the filter while larger particles are precipitated in the mini-cyclone.

The filter discs currently approved by the GME are either 25 or 37 mm in diameter glass microfibre or cellulose nitrate filters with a pore size of 0,8 µm. The glassfibre filters are only acceptable for mass determination, while the latter can be used to determine the particulate composition.

The pump must compensate for pressure differences to ensure a constant airflow of 1,9 l/min. To calculate the average dust concentration, the following calculation is used:

$$\text{Dust conc.} = \frac{\text{Sampled mass}}{[\text{Time} \times \text{Flow rate}/1\ 000]} \dots\dots 4.1$$

$$= \frac{\text{mg}}{\text{min} \times \text{l/min}/1\ 000}$$

$$= \text{mg/m}^3$$

The calculation of the time-weighted average (TWA) concentration is similar where:

$$TWA \text{ (mg/m}^3\text{)} = \frac{\Delta M \times 1000}{r \times TLV-TWA} \dots\dots 4.2$$

where M = sampled mass [mg]  
 1000 = conversion from litres to cubic metre  
 r = airflow rate [l/min]  
 480 = TLV-TWA (eight hour equivalent<sup>2</sup>)

The weighing procedure of the filter should be according to the standard filter weighing procedure as described in "Supporting Documentation no 9: Standard Filter Weighing Procedure (for filter paper only)".<sup>3</sup>

### 4.3.2 Scattered light dust instrument

This includes a RAM, Mini Ram and the Hund TM Data Tyndallometer, a portable dust-monitoring instrument. The system consists of a sampler ... and/or a data collection and/or personal computer program into which measured data are entered and time-related dust concentrations can be displayed and printed. The program also allows for captured data to be manipulated in spreadsheet programs for statistical analyses.

#### *Principle of operation*

This instrument determines dust concentrations using the scattered light principle. To measure the dust concentration, an infrared light beam is generated by a diode and passes through the measuring chamber. The scattered light reflected by the particles is measured at an angle of 70 degrees to the primary beam. The use of this angle in combination with a light wavelength of 950 nanometres corresponds to the deposition probability of respirable dust.

The instrument has the greatest sensitivity to dust particles of approximately 6 µm in size and does not evaluate particles with a size greater than approximately 8 µm. A built-in data logger can store up to 2 000 individual dust readings and will, depending on the sampling time, store averaged individual readings ranging from 2-32 seconds. The result of the measurements is a scattered light intensity value which is directly proportional to the dust concentration.

Prior to measuring, the Hund instruments are placed side by side in an airway with constant flow. Sets of instrument data are used to correlate the different instruments and to determine a bias for each instrument. One instrument is chosen as the base instrument and the correction factors are used to normalize all the instruments.<sup>4</sup>

Calibration of the instruments for determining the dust concentration in mg/m<sup>3</sup> is based on a comparison measurement with a gravimetric respirable dust sampler. The base instrument is used and an equivalent gravimetric factor is obtained. This conversion factor permits the direct determination of respirable dust concentration in mg/m<sup>3</sup> with the Hund.

Where differences in dust concentration are expected to be in excess of say 25 % each tyndallometer should be used in parallel with a gravimetric sampler as the conversion factor varies with the dust concentration

### 4.3.3 Total gravimetric sampler

A number of instruments are available. The most frequently used are a 40 mm filter through which air is drawn at 1,9 l/min. In another sampler used air is drawn through an open faced filter holder by one or more pumps, giving a total air flow of not less than 6 l/min. The dust particles are sucked upwards (instrument placed perpendicular to airflow) through an entry port (50 mm wide and 50 mm long) and deposited on a filter. This method limits the upper size range of dust particles that can be deposited on the filter to approximately 50  $\mu\text{m}$ .

Alternatively the air-entrance can be reduced to increase the entry velocity and consequently the size of the particles to be entrained to ensure a more representative sample of the entrained dust.

Whatman glass microfibre filters of 70 mm diameter and 0,8  $\mu\text{m}$  porosity are used. The same control filter procedure is used as described in section 4.2.4. This sample is used to determine the total dust concentration and analyzed for its particle size distribution.

### 4.3.4 Cascade impactor

The cascade impactor is used as an alternative to the size-analysis of the previously described total dust sample to determine aerodynamic particle size distributions. It utilizes eight impactor stages and the impactor cut-points range from 21 to 0,5  $\mu\text{m}$ . Dust particles smaller than 0,5  $\mu\text{m}$  are deposited on a filter.

#### *Principle of operation*

Air is drawn through the instrument by a pump at a rate of 2 l/min. The inlet visor and cowl prevent debris from entering the cascade impactor. The flow enters the inlet cowl and accelerates through six radial slots in the first impactor stage. Particles larger than the cut-point of the first stage impact on the perforated collection substrate. Then the airstream flows through the narrower slots in the second impactor stage and smaller particles impact on the second collection substrate and so on. The air velocity increases in each of the following stages. The openings are smaller for each stage, increasing the velocity, and particles in different size ranges impact on the different stages.

The substrates are coated with an adhesive before they are weighed prior to sampling. After sampling they are weighed again and the mass difference between the weighings is the mass of dust in each size range.

The fine particles that pass through the final stage are collected by a 32 mm diameter PVC-acrylic membrane filter disc (0,8  $\mu\text{m}$  porosity).

A control filter is weighed at the same time as the filters to be used, after they have been left to acclimatise together. The filters are weighed three times and the average mass is used. The control filter is used to determine the change in mass as a result of the change in the humidity. The sampled filters and the control filter are again left to acclimatize and the difference in the control filter mass before and after the test is either added to, or subtracted from the sampled filter, depending upon the change in mass.

### 4.4 Isokinetic Sampling

To ensure a representative sample of an aerosol (dust and air) to be sampled it is necessary to sample isokinetically. Sampling is isokinetic when the inlet of the sampler, which may be a thin walled tube or probe, is aligned parallel to the gas streamlines and the gas velocity entering the probe is identical to the free stream velocity approaching the inlet<sup>5</sup>.

For isokinetic sampling (from Figure 4.1) the velocities should be equal:

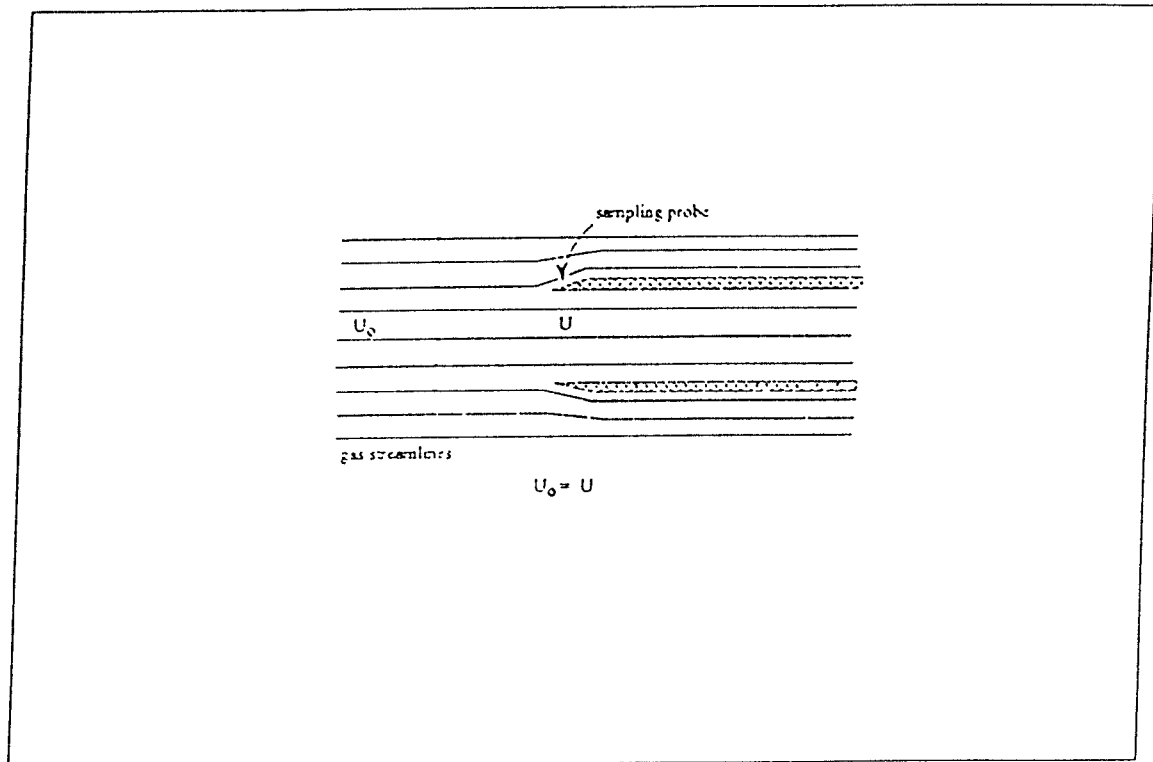

Figure 4.1 Isokinetic sampling

$U_s = U$  where  $U_s$  is the free stream velocity.

This results in a direct relationship between the flow rates and their respective cross-sectional areas. This is shown for a circular duct by

$$\frac{Q_s}{A_s} = \frac{Q_d}{A_d} \dots \dots 4.4$$

$$\frac{Q_s}{Q_d} = \frac{A_s}{A_d}$$

$$\frac{Q_s}{Q_d} = \frac{(D_s)^2}{(D_d)^2}$$

where  $Q_d$  = sampling flow rate  
 $Q_o$  = duct flow rate  
 $D_d$  = sampling probe diameter  
 $D_o$  = duct diameter

**Example:**

The isokinetic sampling rate for a 8 mm probe in a 570 mm duct carrying 4,5 m<sup>3</sup>/s.

$$Q_s = 4,5 \times 1000 \times \frac{(8)^2}{(570)^2}$$

$$Q_s = 0,89 \text{ L/s}$$

## **5 REDUCING THE MAKE OF DUST AND PREVENTING IT FROM BECOMING AIRBORNE**

5.1	Introduction	38
5.2	Comminution of Coal - The Making of Dust	38
	5.2.1 Actions to reduce primary comminution processes	43
	5.2.2 Secondary comminution processes	43
5.3	Entrainment of Dust	45
5.4	Containment of Dust	45

## 5 REDUCING THE MAKE OF DUST AND PREVENTING IT FROM BECOMING AIRBORNE

### 5.1 Introduction

This chapter deals with reducing the amount of dust which is made and then "released", or happens to get into the air. No matter how much dust is made in the comminution process it is the fact that the fine particles end up in the air and thus is a problem. It is, significantly, more difficult to remove the dust out of the air than to keep it contained in the broken coal mixture.

In keeping with the strategy, efforts should be directed at making as little dust as possible and, then to stop dust that has been made from becoming airborne either through minimizing the amount of energy that is put into the coal, or by containing the dust in the coal so that cannot be released.

In order to apply these dust combatting principles it is important to know how the mechanisms involved work. Through the understanding of these mechanisms, those involved with the task of dealing with dust will be able to devise the methods most suitable for their particular circumstances.

### 5.2 Comminution of Coal - The Making of Dust

Dust is formed by fine particles which become airborne form during the comminution, or breaking, of coal. It follows that if the amount of very fine coal that is formed can be reduced, then the amount of particles that can be released into the air must also be reduced.

In regarding comminution of coal using continuous miners we will be considering two types of mechanisms. The first is the breaking of the coal from the solid by the cutting drums of the continuous miner and the second is the secondary breaking of coal in the loading and transport process. In the case of the first mechanism the energy supplied to the coal is meant to break it from the solid, whereas in the second case the energy supplied to the coal is to move it or is a necessary part of the moving process. The exception to the latter is where crushers are used to break the coal so that a more even size of coal can be loaded onto a conveyor belt, as is the case with in-section breakers or crushers. These mechanisms will be considered as a secondary comminution process rather than a primary process.

In using continuous miners the coal is basically torn from the solid by the cutting drum. This process of breaking the coal into smaller pieces creates dust through various mechanisms

To understand how dust is formed in the coal breaking process it is necessary to know some fundamental aspects of the coal cutting process

To enable the cutting pick to remove coal from the solid it has to be pushed into the coal and then move through the coal at a certain depth. The force required to push it into the coal is called the *normal force* and the force required to push it through the coal is called the *cutting force*.



The physical properties of coal is such that its tensile strength (resistance against pulling) is significantly less than its compressive strength (resistance against pushing). The coal cutting process makes use of this characteristic and coal is broken by using the wedging action of the pick to break the coal.

(See Figure 5.1 showing the forces and the wedging action)

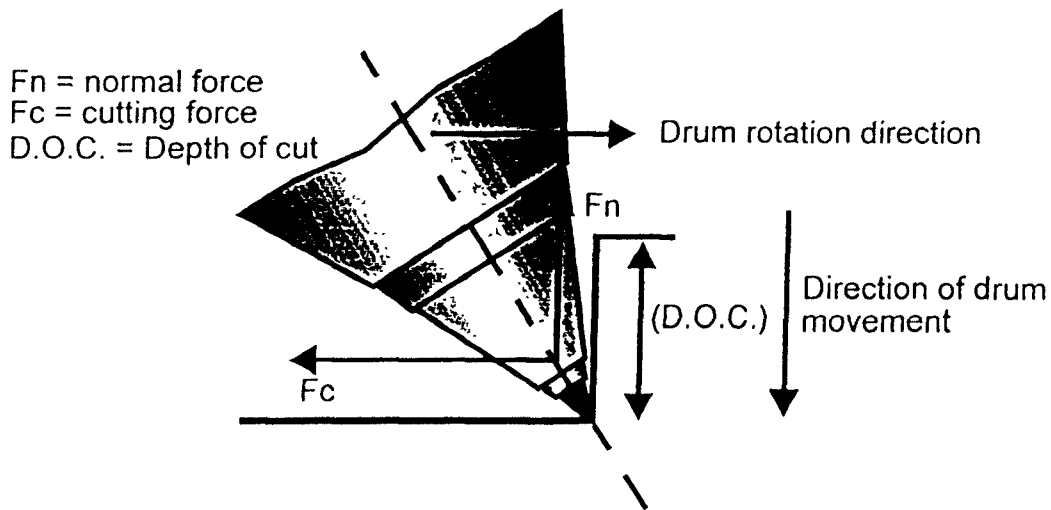

Figure 5.1 Forces during cutting process

As coal has cracks and cleats, as well as a naturally occurring plane of weakness the breaking of coal by tensile forces causes the coal to part on these weaknesses. This leads to less smaller coal being produced than would have been the case if the coal was homogeneous.

Even if the pick is in a good and sharp condition there is still other mechanisms whereby a compression force occurs between the pick and the coal.

The first of these is when the pick enters the coal. For the pick to be able to exert enough force to break out a piece of coal it has to move into the coal. The only way it can do this by crushing the coal in front of the pick. The sharper the pick the less the amount of force needed for the pick to enter the coal. This crushing of coal creates some fine coal and as the point of the pick become blunt a greater amount of force will be required to push it into the coal and a greater amount of fine coal will be produced.

Another area is where the body of the pick is forced against the coal by normal forces. This creates a path along which coal is being ground into fine particles by the pick. When the pick becomes blunt this area of friction increases and significantly more coal is crushed forming dust.

(See Figure 5.2 where the passage of a sharp pick is compared to that of a blunt pick )

The breaking of coal by means of cutting conforms to the rules of comminution in that the amount of energy expended to cut the coal is proportional to the new area that has been exposed

The energy required to cut coal is termed the specific energy and is influenced by the following factors (This means that the amount of fines produced in the cutting process

is therefore also influenced by the same factors).

**(a) The depth of cut (DOC)**

The depth of cut is the amount that the picks moves into the coal during one revolution of the cutting drum. If the drum moves slowly into the coal or the revolutions of the drum is very high this amount becomes small. Based on previous research work done locally and internationally it has been found that the relative amount of forces required become higher. Although the amount of forces required to push the pick into the coal, or to make the drum, is lower at the shallower depth of cut, the relative forces is significantly higher. This means that the amount of energy required to cut the coal has increased. The main reason for this increase in energy is because the coal has been broken into smaller fragments.

With blunting picks the forces required to cut the coal increase and therefore the DOC decreases. The blunting of picks thus not only increases the make of fine particle by its passage through the coal but also on the effect it has on the depth of cut of the picks.

**(b) The relationship between the DOC and the pick spacing**

Previous work into coal cutting has indicated the effect of the spacing to DOC relationship on the specific energy required to cut the coal. This effect is mainly due to the way and the angle formed when the coal breaks out. When the picks are too far away, there is no interaction between the picks on a drum, and there will be areas left between the grooves caused by the picks. These areas cause problems when the pick comes around for the next pass as the amount of coal that has to be removed will have increased. This cause problems with the forces and the energy requirements increase dramatically. On the other hand if the picks are too close to each other, then the breakouts overlap and the cutting process does not utilize the effect of the breakout, and has the effect of a lower amount of coal to show as output. This increases the specific energy because the amount of fine that has been created has increased.

(See Figure 5.3 showing the effect of too close a pick spacing and too big a pick spacing.)

From work done at the Chamber of Mines Research Organization (COMRO) it was found that the most appropriate spacing to depth ratio for South Africa coals lay in the order of between 1 and 2.

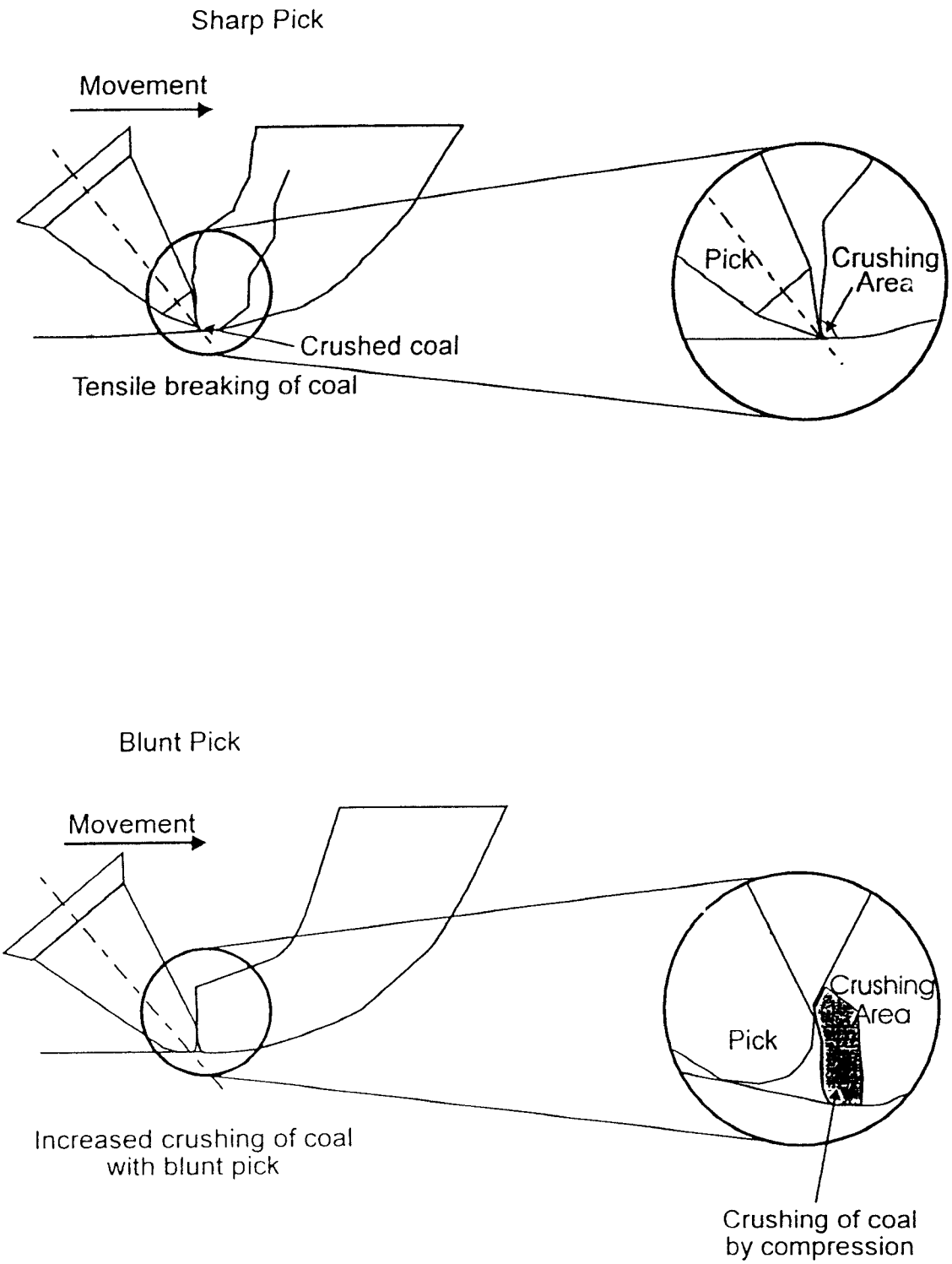

Figure 5 2 Comparison between blunt and sharp picks in the creation of dust

## (c) The continuous miners ability to generate thrust

The cutting of the coal by a continuous miner consists mainly of two parts, the sumping part and the shearing part. During the sumping part of the cut the continuous miner forces the revolving drum into the solid coal by means of its tractive effort. The rate at which this can be done is determined by a balance between the available tractive force and the total resistance of the coal against the drum. The total resistance against the drum is the sum total of the normal forces experienced by all the picks in contact with the coal. As the drum enters the coal the depth of cut increases and the sum of all the normal forces also increases until it is in balance with the force exerted by the continuous miner.

In the shearing part similar types of forces are generated by the picks during the

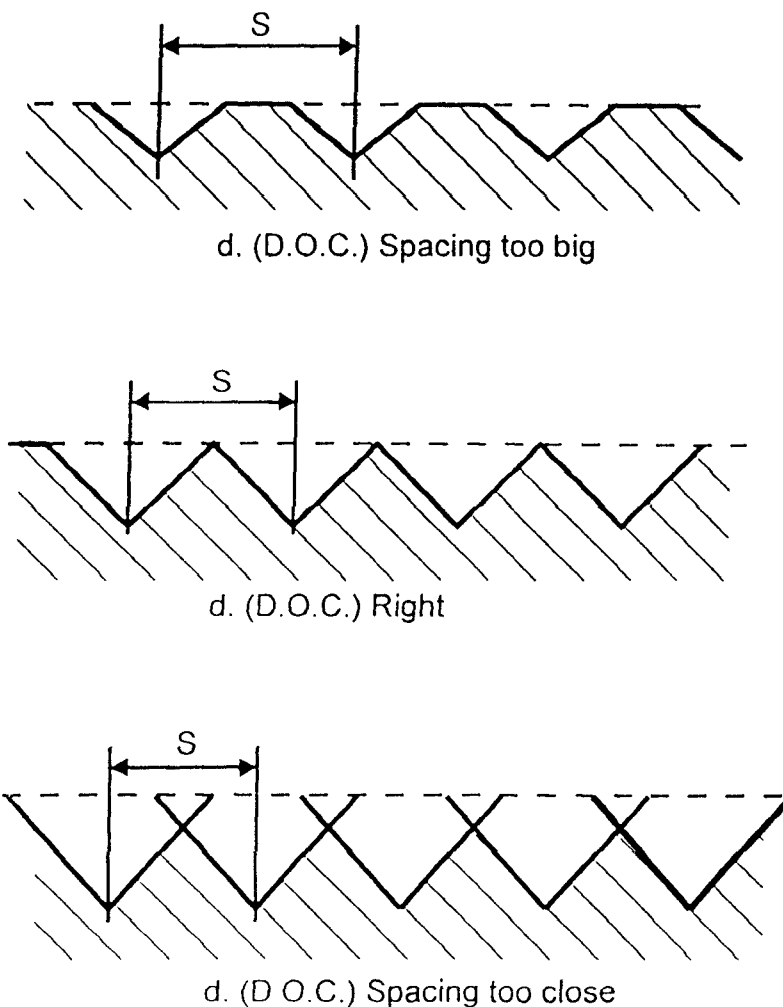

Figure 5 3 Effects of changing the ration between DOC and pick spacing

shearing movement but these are now balanced by the force generated by the boom jacks of the continuous miners, as well as the weight of the machine (If the weight of

the machine is less than the force generated by the jacks the machine could be lifted).

The force generated by the continuous miner is a function of the traction of the machine which, in turn, is determined by the coefficient of friction between the tracks and the floor and the weight of the machine.

The coefficient of friction of the tracks of a continuous miner is usually increased by the grousers on the pads. When these grousers are worn down then the friction decreases and the machine loses its capacity to cut coal. Another method of increasing a continuous miners ability to cut coal, using deeper depth of cuts, is to increase the weight of the continuous miner.

As the dynamic coefficient of friction is lower than that of the static coefficient of friction trackslip on a continuous miner has to be prevented. Once the tracks of a continuous miner starts slipping continued pressure to keep the tracks moving will not increase it forward but will, in actuality, keep it at a lower value. The tracks should be stopped so that static friction values are used and the sump should only then continue.

### 5.2.1 Actions to reduce primary communication

- (i) Maintain sharp picks or picks in a good condition
- (ii) Install drums with the right spacing to depth ratio
- (iii) If the coal and drum design allows it cut with the slowest drum speed
- (iv) See that the friction on the tracks are at maximum so that increased sumping rates can be maintained

### 5.2.2 Secondary comminution processes

The other mechanism whereby the coal is broken into smaller particles will be called the secondary comminution process. This is the process or processes in the normal mining process whereby the coal that has already been broken from the solid is broken even further, creating smaller particles and therefore making the potential for dust release even greater.

The processes under consideration will include:

- (i) Secondary comminution in coal cutting process
- (ii) Comminution in the loading process, including crushing or decreasing of coal size in the section and comminution in the transport process.

It should be pointed out that although some of the processes are necessary, secondary comminution of coal is not always a negligible matter for mines. Apart from the generation of dust size particles, the whole size of the coal can be made smaller. This might not be a matter for concern to mines that feed the coal to a power station where the coal is pulverised, but can be matter of great concern to mines where the coal with larger sizes are sold at a better price to the customer. Increasing the coal size will thus not only decrease the potential for the release of dust but can also increase the unit

income per ton of coal.

*(i) Secondary comminution during the cutting of coal*

The secondary comminution during the coal cutting process occurs mainly when the liberated coal cannot be cleared from the drum.

One ton of coal in the solid has a volume of about .66 cubic meters. The same ton of coal in a broken form will have a volume of over one cubic meter. Thus by the very process of cutting the coal from the solid the coal undergoes a volume increase in the order of 50 %. If the cutting drum is not designed to allow this coal to be released, and flow away from the cutting area, the coal is contained and will undergo further crushing due to its own expansion, as well as due to the movement of the drum. This containment of the coal not only creates comminution but also puts more load on the continuous miner.

When the normal procedure of sumping in at the top and shearing down is followed then the coal has a fairly easy escape route to the bottom of the drum. When the drum cuts closer to the floor and cuts into the heap of coal already there, secondary comminution occurs. When the process of sumping in at the bottom is followed, then a process of upwards shearing has to be used. In this situation the coal still has to escape to the bottom of the drum but the majority of coal expansion occurs at the top of the drum where the depth of cut is the greatest. This coal then has to pass around the whole path where the drum is in contact with the face. Because the coal is contained, and subject to movement significant secondary comminution must occur.

Another activity that leads to secondary cutting comminution is when the continuous miner is used to clean up coal on the floor while using the drum at the same time. The drum will act as a rotary breaker on the coal through action of trying to scrape in onto the shovel. Apart from causing more dust it is a very expensive method, in terms of capital equipment to clean a section.

To prevent secondary comminution in the coal cutting process attention will have to be paid to the following:

- Use a drum that enables the coal to be cleared from the cutting area and that does not constrict the flow of coal
- Use the normal sump and shearing process
- Do not use the continuous miner as a loader, rather use equipment like LHDs to clean up a section. Where it is unavoidable, do this action without the drum turning.

*(ii) Secondary comminution during the loading process*

Secondary comminution of the coal mix occurs in the coal loading process basically due to the coal falling for a distance, obtaining energy which is then dissipated through plastic deformation when the falling particle strikes another object or comes to rest at the bottom of their downward path. As coal can be deemed to be a brittle material, the dissipation of energy into plastic deformation without breaking is very low, i.e. the majority of such energy will be used in breaking the coal into smaller particles. This action is very similar to the process of autogenous milling where the particles are broken through falling and being impacted by other particles of the same material.

As the coal is transferred from the back of the continuous miners conveyor onto the shuttlecar it drops and undergoes an amount of breakage. In a similar fashion the coal

undergoes breakage wherever it is allowed to drop at transfer points. By diminishing the height that the coal is dropped from, the amount of energy transferred to the particles is kept to a minimum and therefore the amount of coal that is broken is reduced. It should be noted that it is not the action of the coal striking a hard surface that really causes the comminution, although this exacerbates the situation, but more the act of falling and the subsequent dissipation of the stored energy.

The coal falling to the ground must also have the effect of breaking the coal, but as it is such an integral part of the mining process there is actually very little that can be done about it.

A further action that can cause the comminution of the coal is through the action of the loading arms of the continuous miner. If these arms are designed so that they move the coal around, while not moving the actual coal mass then the energy transferred to the coal can cause the breaking of the coal into smaller particles. This can occur when spinner type loaders are being used rather than gathering arm types. If the shovel is overloaded, thereby constraining the mass through the sheer volume that is present, the energy from the arms will be transferred into the breaking of the coal mix as it cannot effect movement.

In the transport process there is still another area where coal can be ground into finer particles. When the coal clings to the conveyor belt and it goes between the rollers and the belt, it is subjected to severe and continued forces. Although the visible reduction in size does not seem great, this mechanism, due to its continuous nature, can cause the creation of a large amount of dust sized particles, as well as releasing them.

#### **ACTIONS TO REDUCE SECONDARY COMMUNICATION DURING THE LOADING AND TRANSPORT PROCESS**

- Minimize energy transfer by choosing the right loader arms for the type of coal and process
- Minimizing the drop height in coal transfer points
- Establish belt cleaning devices that stop coal from being drawn back on the return belts
- Minimize the crushing action on the coal mix in the crusher.

### **5.3 Entrainment of Dust**

Still to be done in keeping with fundamentals.

### **5.4 Containment of Dust**

Same as above

The entrainment of dust is the mechanism whereby the dust particle is "grabbed" by a source of energy so that it leaves the point in the mix and is released in the air. The source of energy will then keep this particle in the air.

This mechanism is best explained at the hand of how air interacts with a dust particle  
Freefall or settlingout speed.  
energy to keep it in the air

The containment of dust has basically to do with ensuring that the forces conating the small coal particles in the mix is larger than the forces that it is subjected to that would be able to liberate them.

When coal is contained in the coal mix it will be in a loose form but more likely it will be adhering to another similar particle of different size. This adhering of particles to another can be enhanced by several means in the mine. The first and most important is the use of water.

A chisel pick breaks primarily in the direction of movement and a conical or point attack pick breaks primarily sideways. However both picks exploit the same weakness, that of a lower tensile strength to effect breakage<sup>1</sup>.

Point attack Picks have a tendency to make more dust at smaller pick penetrations.



## **6 DUST SCRUBBERS**

6.1	Introduction	47
6.2	Dust Behaviour	47
6.2.1	Particle motion	48
6.2.2	Particle collection	48
6.3	Wet Scrubbers	52
6.3.1	Flooded-bed scrubber	53
6.3.2	Wet fan scrubber	54
6.4	Parameters Affecting Efficiency	55
6.4.1	External factors	55
6.4.2	Operational factors	56
6.4.3	Scrubber operations	61

## 6 DUST SCRUBBERS

### 6.1 Introduction

The use of scrubber systems to control the airborne dust in the face area where mining takes place has recently gained favour.

The efficiency of such systems in removing the dust generated at a coal mine face has been proved in many coal mines. It should, however, be borne in mind that the on-board dust scrubber is only part of a larger dust-suppression system and that scrubber efficiency is only part of the total effectiveness of the dust-control system, which includes the ventilating pattern.

In a system that operates at 90 % scrubber efficiency, 10 % of the dust would still be released into the mine atmosphere.

The wet scrubbers most widely used in the South African coal mining industry are the flooded-bed scrubber and the wet fan scrubber. Wet scrubbers are designed to use water to scrub or clean the air. The operation of the scrubber systems themselves are described later in this chapter.

In order to understand the requirements for the proper operation of a scrubber, it is essential to understand, not only its physical operation, but also the relevant properties and behaviour of the dust in the system.

It must be remembered that certain external factors such as maintenance, the condition of the scrubber, the position of the scrubber, etc. will influence the capture efficiency of a scrubber.

### 6.2 Dust Behaviour

Wet scrubbers are required to operate efficiently for a wide range of dust particle sizes. The efficiency of any dust-removal facility is expressed in terms of the percentage or mass of particles removed. The mass dust-removal efficiency can be determined from the following equation:

$$\eta_m = \frac{(mass_i - mass_o)}{mass_i} \times 100\% \quad 6.1$$

where  $\eta_m$  = mass dust removal efficiency (%)  
 $mass_i$  = mass in ( $mg/m^3$ )  
 $mass_o$  = mass out ( $mg/m^3$ )

The efficiency can also be reported as either a total dust efficiency or a respirable dust efficiency or in specific particle size ranges.

### 6.2.1 Particle motion

Particle motion is a complex science and would take several chapters to describe in detail. In relation to scrubbers, only curvilinear motion is addressed as most of the particle movement around obstacles (for removal) is curvilinear. Particle motion is described in greater detail in other chapters of this document.

Particles approaching an obstacle, such as a single fibre in a fibrous screen, will flow along streamlines passing the obstacle or will come into contact with the obstacle and adhere to it. Flow around an obstacle can be described in terms of potential or viscous flow.

Potential flow assumes an ideal fluid and that flow is non-rotational. As no viscosity is assumed, no film of fluid forms on the obstacle. The highest velocity is closest to the obstacle.

Viscous flow, as the name indicates, takes viscosity into account, resulting in a stagnant surface film of fluid. The drag generated at the obstacle increases away from the obstacle, resulting in increased velocity.

It can be concluded that the assumption of viscous flow is more accurate close to the obstacle's surface and potential flow is more correct a short distance away from the obstacle. Actual flow close to an object would not follow the indicated streamlines, as there would be eddies up- and downstream of the object and these would distort the flow pattern.

### 6.2.2 Particle collection

The most common means of particle collection in a scrubber system are: impaction, interception and Brownian diffusion.

These mechanisms interact to effect the total collection of dust particles from a gaseous medium. The mechanisms by which dust is removed from a gaseous medium are described briefly below.

#### *(i) Impaction*

Impaction is the most prevalent means of particulate removal<sup>1</sup>. Owing to their greater specific mass, dust particles have more inertia than gas. Resistance to a change in momentum allows the particles to cross streamlines. Thus, even fine particles can deviate from the gas streamlines and impact on an obstacle or a water droplet. Figure 6.1 illustrates the process of impaction for dust particles.

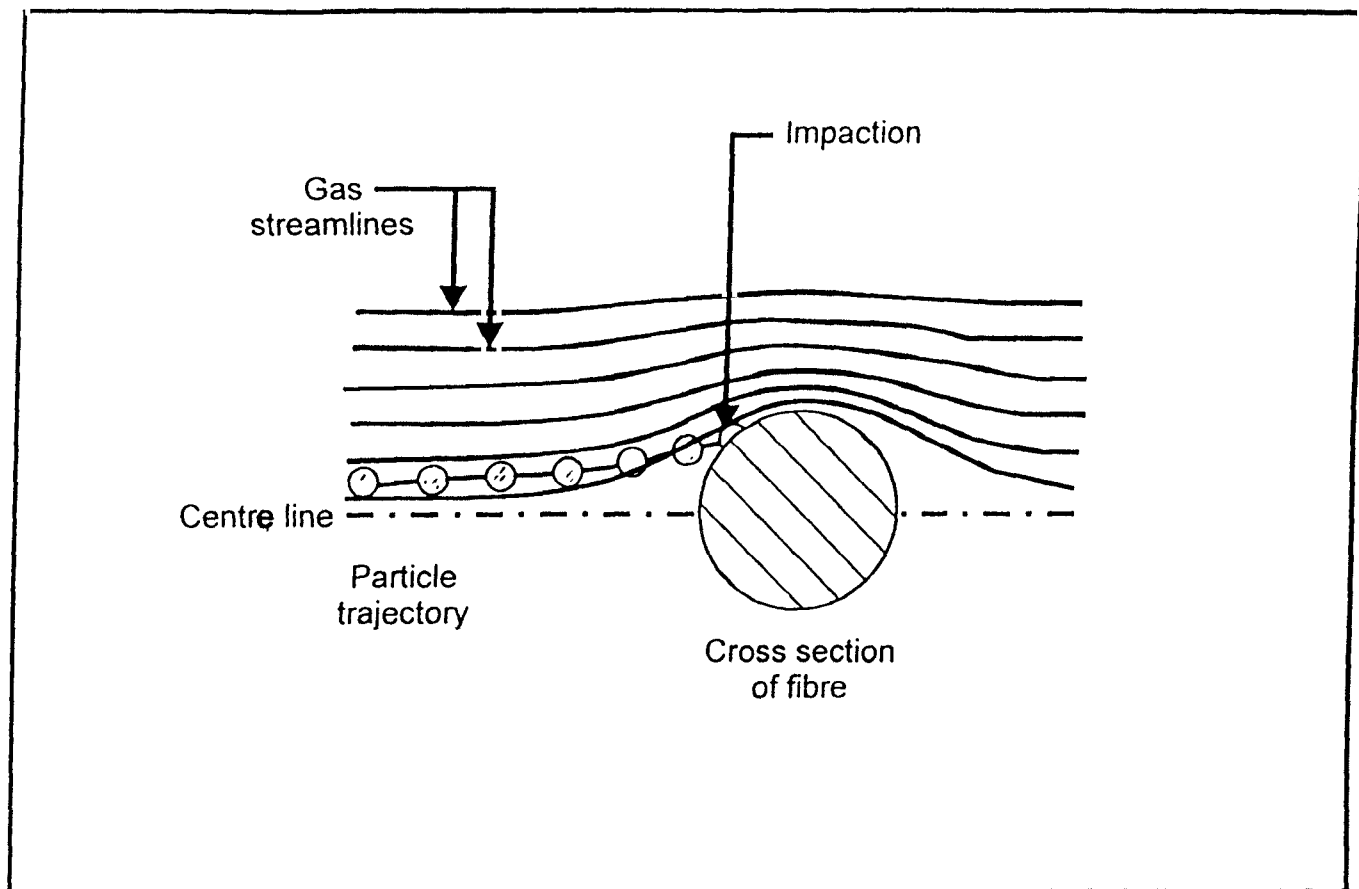

Figure 6.1 Process of impaction

Inertial impaction efficiency is frequently reported as the impaction parameter  $K_1$ , which refers to the Stokes number ( $St$ ). The expression for the impaction parameter applies to spherical fine particles that obey Cunningham's correction<sup>2</sup>:

$$K_1 = St \cdot \frac{d^2 \rho_p v C}{9 \mu_g D_c} \dots \dots 6.2$$

where  $d$  = particle diameter ( $\mu\text{m}$ )

$\rho_p$  = particle density ( $\text{g}/\text{cm}^3$ )

$v$  = velocity difference ( $v_p - v_g$ ) ( $\text{cm}/\text{s}$ )

$C$  - Cunningham's correction

$\mu_g$  - viscosity of gas [poise]

$D_c$  - diameter of collector [cm]

It can also be expressed as:

$$K_1 = St \cdot \frac{2X_s}{D_c} \dots \dots 6.3$$

where  $X_s$  - particle stopping distance

If the impaction parameter increases, the particle-removal efficiency increases. This can, for example, be achieved by increasing the velocity difference between the dust particles and the water droplets.

When a particle approaches an obstacle on the stagnation streamline a critical Stokes number is defined ( $St_c$ ). Thus for all other particles  $St > St_c$ , for particles to impact on an obstacle.

(iii) *Interception*

Interception occurs when particles do not impact directly on an obstacle<sup>3</sup>, but meet it at angles of less than 90°. These particles may adhere to obstacles as they attempt to pass them or may be engulfed when contacting a water droplet. The mechanism of interception is illustrated in Figure 6.2.

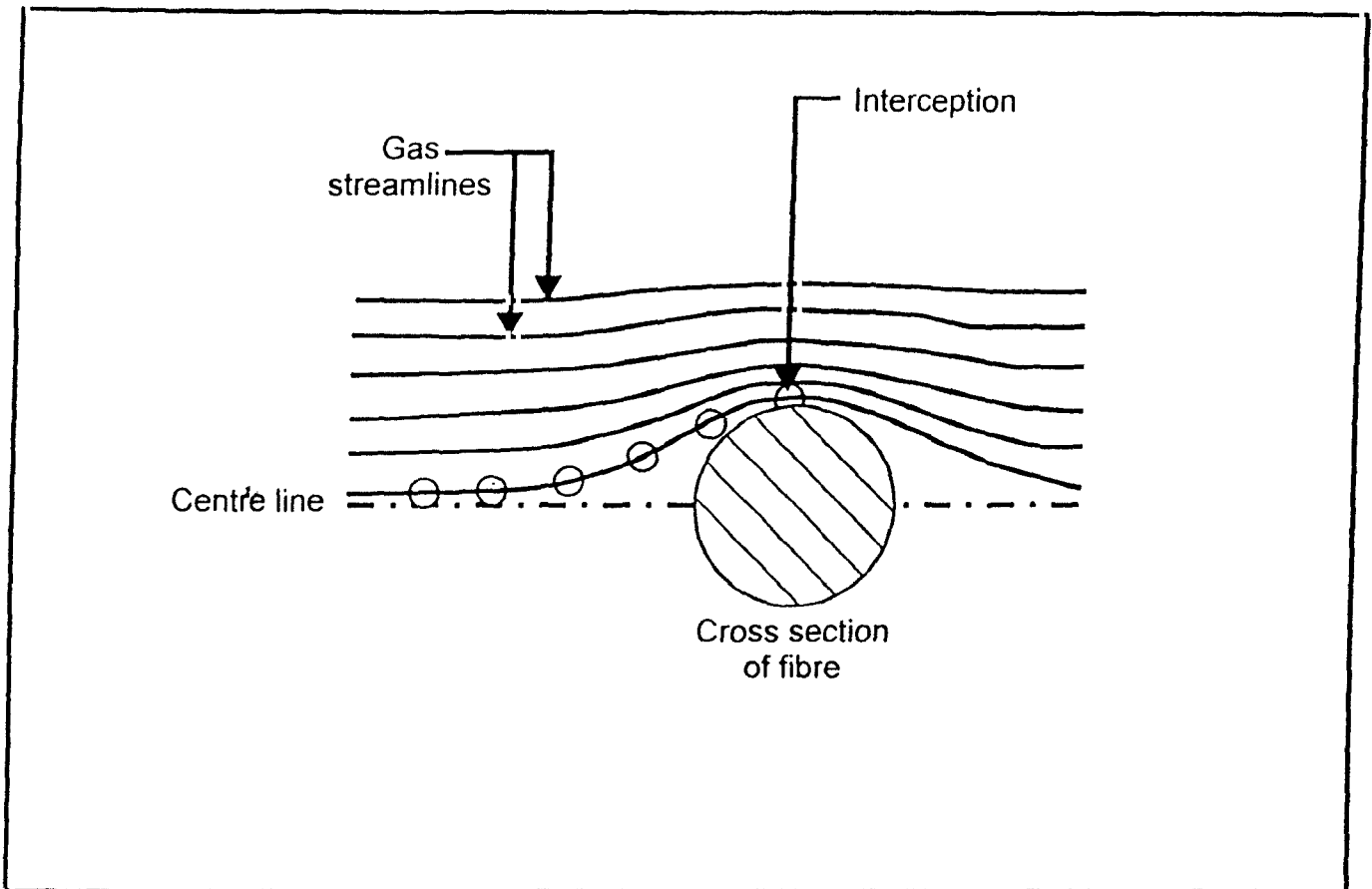

Figure 6.2 Process of interception

Interception due to water droplet action is related to droplet density, i.e. an increase in droplet density increases the chances of interception. Droplet density can be increased either by using water sprays that deliver a finer spray mist or by increasing the water pressure. There is, however, a limit after which a decrease in water droplet size decreases efficiency. This is reached when the concentration is so high that coalescence occurs, resulting in larger droplets and a decrease in efficiency. Interception is most prevalent with submicron particles which tend to follow gas streamlines.

(iii) Diffusion

Diffusion of particles becomes more significant as particle size decreases<sup>4</sup>. This is a direct result of the smaller mass of the particles, which decreases the inertia<sup>5</sup>. These particles thus move in a random diffusive motion, also known as Brownian motion. The diffusive movement of a particle and the capture thereof are shown in Figure 6.3.

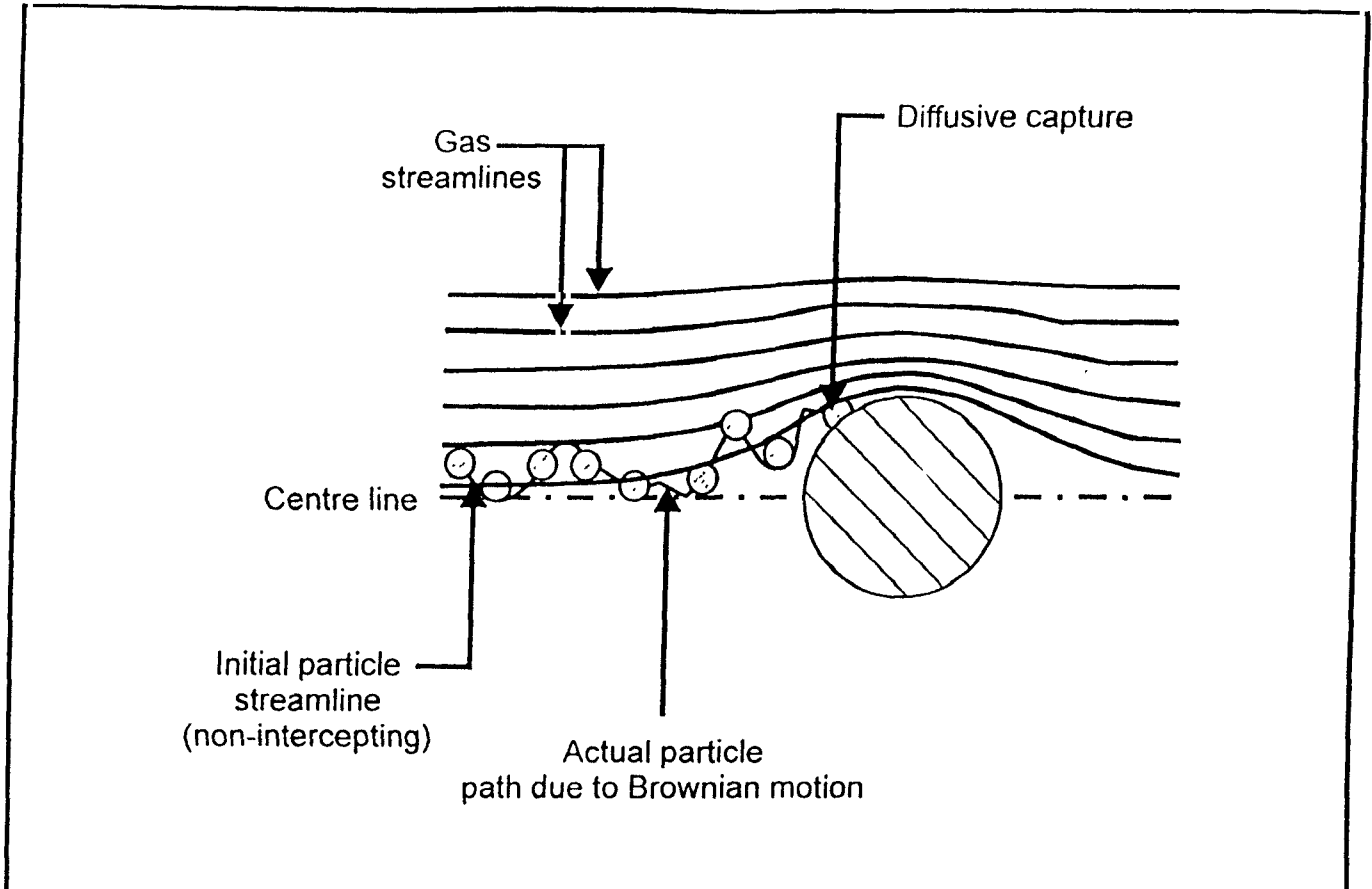

Figure 6.3 Diffuse particle collection

Diffusion occurs along lines of irregular gas density, turbulence and temperature. The effect of diffusion decreases in a system where the gas flow velocities are high. Diffusion is most prevalent with particles smaller than  $0,5 \mu\text{m}$ .

It can be concluded that inertial impaction and interception are the predominant mechanisms by which particles  $> 1 \mu\text{m}$  are removed from dust-laden air. As the particle size decreases, the efficiency of particulate removal decreases.

Diffusion is the predominant mechanism in the removal of particles  $< 0,1 \mu\text{m}$ . Particles between  $0,1$  and  $1 \mu\text{m}$  are the most difficult to remove from the air as none of the collection mechanisms is particularly effective for that size range.

### 6.3 Wet Scrubbers

A great variety of scrubbers are available, including:

- spray scrubbers
- wet dynamic scrubbers
- cyclonic spray scrubbers
- impactor scrubbers

- Venturi scrubbers
- augmented scrubbers.

The scrubbers in use in the South African mining industry are the flooded-bed scrubber and the wet fan scrubber. In both, impaction is the primary means of particle removal for particles greater than  $3\ \mu\text{m}$ . It has been demonstrated in scrubbers actually in operation that particles above  $3\ \mu\text{m}$  tend to exhibit inertial effects (momentum, inertia, kinetic energy, etc.), whereas particles below this size tend to follow the gas streamlines, resisting settling and inertial means of capture<sup>6</sup>. To capture finer particles, higher water pressures and smaller droplet sizes are required.

### 6.3.1 Flooded-bed scrubber

The scrubber assembly consists of the following main components:

- scrubber box
- spray nozzles (wide-angled)
- filter screen
- demister
- sump and non-return valve assembly
- fan (18,5 kW, 30 kW or 37 kW).

The nozzles spray water to cover the whole screen area uniformly. This is done to create a water bed into which dust particles impact and are captured and flushed away. The screen is made up of multi-layered, knitted, stainless steel wire mesh, with another closely woven screen of stainless steel wire in front. The primary function of the screen is to capture dust particles engulfed in the water droplets. The demister is typically constructed from galvanized steel or PVC and the sheeting is placed (staggered) in such a manner that water droplets are removed from the air stream. New PVC demister plates are being developed to decrease the weight of the demister.

The layout of a flooded-bed scrubber is shown in Figure 6.4.

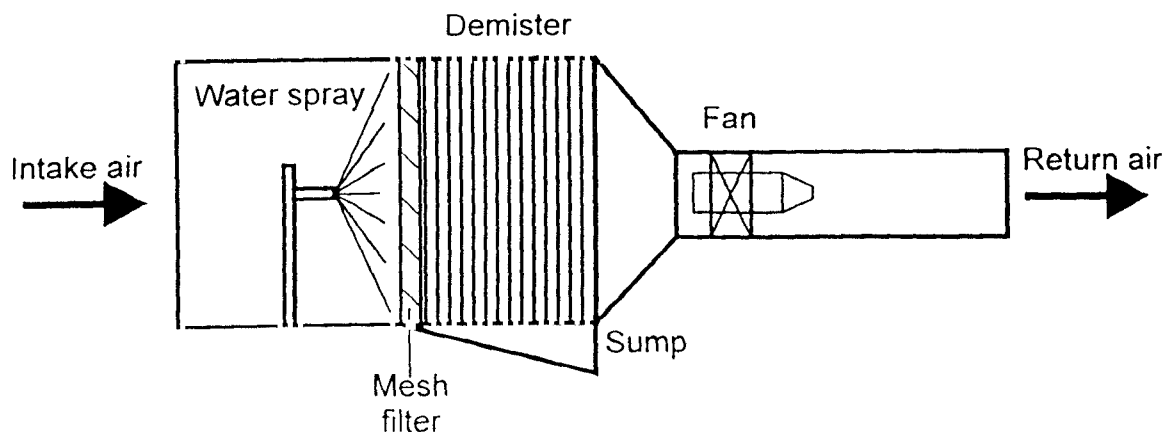

Figure 6 4 Flooded-bed scrubber layout



The intake air is drawn into the wet scrubber area, passes through the irrigated filter screen and then through the demister in which the dust-laden water is removed and drained through the sump, with dry air leaving across an axial flow fan.

### 6.3.2 Wet fan scrubber

A wet fan scrubber normally consists of the same components as a flooded-bed scrubber, the main difference being that the sprays are located in front of the fan and the fan is installed in front of the demister. The use of screens can improve scrubber efficiency.

Water sprays installed in front of the fan deliver water droplets which are intimately mixed with the dust-laden air. The high turbulence and velocity created, combined with the centrifugal force, ensures good scrubbing of the air. The polluted water collects around the fan casing, from where it is removed.

This system, when combined with a fibrous screen downstream of the fan, ensures a combination of dust-capturing mechanisms. They include scrubbing, impaction around the impeller and scrubber box, and filtering through the mesh filter. A simplified layout of such a system is shown in Figure 6.5.

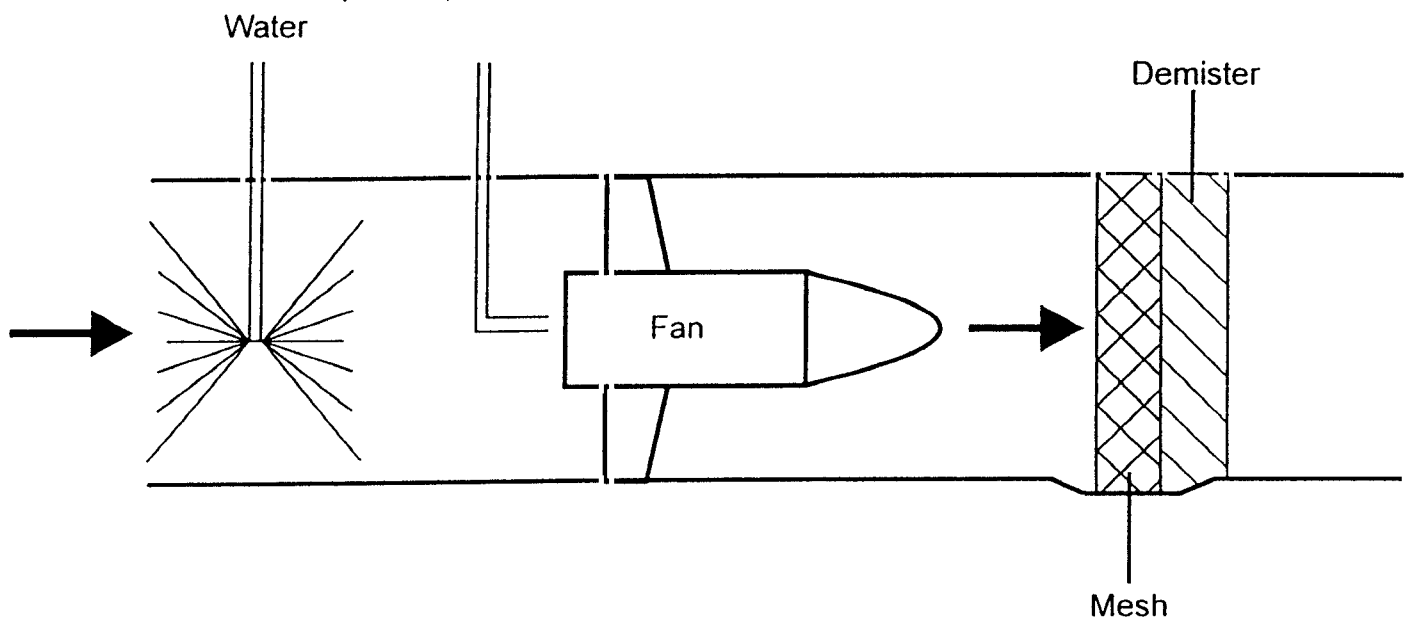

Figure 6.5 Wet fan scrubber layout

The water is directed at the fan impeller where it is atomized by centrifugal force and directed outwards to the scrubber box. This forces the submicron water droplets to cross the air stream and forces the droplets and dust outwards. Most of the water is removed in this region, the remaining water being removed by the demister, and clean air leaves the scrubber. In certain scrubbers the mist eliminator consists of a thick mesh screen.

## 6.4 Parameters Affecting Efficiency

The parameters affecting scrubber efficiency can be divided into system parameters and external parameters such as maintenance, training, the position of the scrubber inlet and various other operating influences.

The system parameters include screen density, velocity, water flow through the spray nozzles and demister type. It must be remembered that maintenance will influence the operation of the scrubber system and thus all the inherent system parameters.

### 6.4.1 External factors

#### (i) Maintenance

The system parameters are in many instances not controllable as they are determined by the manufacturer. Maintenance is the single most controllable external parameter and often exercises the greatest influence on the scrubber's operational efficiency.

Much responsibility for the actual operational inefficiency of scrubber systems can be laid at the doorstep of poor maintenance, damage to or misuse of systems. This has been found in various studies performed by the CSIR<sup>6</sup>.

The manufacturer's maintenance schedule includes daily and periodic maintenance<sup>7</sup>. The aspects (components) that need to be inspected and the action that can be taken on faults found, should be incorporated into the mine's standard procedures. An example of the aspects (components) that need to be inspected and the action taken on fault finding is shown in the following tables:

TABLE 6.1  
DAILY MAINTENANCE

COMPONENT CHECKS	ACTION
Scrubber sump	Backflush
Screen water sprays	Check operation and clean if necessary
Filter screen	Inspect and clean if necessary
Door seals	Inspect and repair if necessary
Non-return valve assembly	Check and repair if necessary
Water filters	Backflush
Fan motor	Check flame proof condition
System	Start up, check for visible faults and correct if necessary

TABLE 6.2  
PERIODICAL MAINTENANCE

COMPONENTS CHECKS	ACTION
Backflush filters	Strip, inspect and clean
Screen water sprays	Remove, clean and refit or replace if necessary
Filter screen	Remove, inspect and clean or change screens
Door seals	Inspect all seals and repair if necessary
Demister	Inspect, repair and replace if necessary
Non-return valve assembly	Inspect and repair if necessary
Sump	Backflush sump until clean water runs out
Mounting bolts	Check, fasten or replace if necessary
Fan motor	Check flame proof condition and repair if necessary
System	Start up, check for water leaks and abnormal noise from fan and repair if necessary

To ensure that maintenance is carried out according to schedule and in compliance with the guidelines laid down, pre-use checklists should be used. Scrubber maintenance should be incorporated into the daily maintenance schedule, together with all other systems on the continuous mining machine e.g. the spray-fan system.

*(iii) Training*

Proper maintenance of a system will only be possible if the personnel responsible for such work are trained. Training should be aimed at ensuring a fundamental understanding of the system's operation, as well as an understanding of the factors which could influence the system's performance (dust-removal efficiency). Training by the mine itself can be supplemented by more specialized training provided by the product manufacturers.

#### 6.4.2 Operational factors

The effect that damage to a system will have on any of the parameters must not be underestimated. If, for example, the scrubber box is damaged, there may be gaps between the screen and the scrubber box, resulting in dust-laden air bypassing the screen without being cleaned. The inherent scrubber parameters thus depends heavily on maintenance and repair of damage to the system.

An extensive testing programme by Miningtek has shown the effect that certain system parameters have on the scrubber efficiency<sup>a</sup>. A short description of some of

the results of this programme is given below.

### **(a) Screen density**

The density of the screen affects the capture of fine particulate matter. An increase in screen density results in an increase in the dust-removal efficiency. This is true for the removal of both coal-dust particles and quartz particles. Studies by the USBM<sup>9</sup>, using different screen densities and tests conducted by Du Plessis, et al<sup>9</sup>, confirmed this fact. In the tests conducted by Du Plessis et al, an optimum screen density was identified after which efficiency dropped. This is attributable to the drop in velocity across the screen which results from the increase in the pressure drop across the screen. By increasing the mesh density, the pressure drop would be increased causing the velocity to decrease. This implies that a change in a single parameter could change the operation of the whole system. These two identified efficiency parameters would thus work against each other. An increase in the pressure drop across the screen, be it intentional or the result of blockage by dirt, will influence the operating cost ( $pQ$ ) and volume flowrate through the scrubber.

### **(b) Velocity**

Increasing the velocity of the gas flow should increase the scrubbing efficiency. The impaction  $K_1$  (subsection 6.2.2) is directly related to the velocity difference between the dust particles and the water droplets.

Thus by increasing the velocity, the effect of impaction should increase as the inertia of the particles increases. The limitation of velocity is the effect that excessive velocity has on re-entrainment or the "bounce-off" effect from the screen or demister. The re-entrainment of water droplets carried through the demister becomes problematic at higher velocities (typically  $> 5$  m/s).

### **(c) Water supply**

Water is used to cover the screen area of the flooded-bed scrubber to enhance the dust-capture efficiency. The use of water also reduces the effect of "bounce off" of particles. Effective flushing of the screen is achieved with 10 - 20 l/min per  $m^2$  of screen area.

Where the water sprays discharge in the same direction as the airflow, the scrubbing effect of the water droplets in the air, and the droplet residence time, in the area in front of the screen or fan are limited. Reversed water-flow direction results in better scrubbing of the air and increased capture of respirable dust because of higher velocity differences between the dust particles and water droplets, and longer residence times.

It was concluded that for the flooded-bed scrubbers, when the water sprays were directed at the screen, the increase in the water flowrate resulted in more effective covering of the screen but did not utilize the scrubbing effect that would be obtained if the water sprays were operated in the opposite direction to the airflow. This was confirmed by the particle-removal efficiency.

The particle-removal efficiency of a spray is given by the following equation:

$$\eta_p = 1 - \exp\left(-\frac{3}{2} \frac{E}{D_w} \frac{W}{Q} L\right) \quad 6.4$$

where $\eta_p$	=	particle removal efficiency of a spray
$E$	=	efficiency of capture by a single droplet
$D_w$	=	droplet diameter ( $\mu\text{m}$ )
$W$	=	water flowrate (l/s)
$Q$	=	air flowrate ( $\text{m}^3/\text{s}$ )
$L$	=	length /distance (m)

This equation shows the various factors that influence the operation or effectiveness of water droplet action inside the scrubber.

The dust-removal capacity of water sprays is a function of the efficiency of a single droplet. This efficiency increases as droplet size decreases.

An important aspect of capture efficiency is the water-to-air ratio ( $W/Q$ ). A practical range for this ratio is given by McPherson<sup>10</sup> as between 0,3 and 0,6 l/m<sup>3</sup>. Also important is the residence time of the water droplet which is closely related to the distance( $L$ ) in Equation 6.4.

In tests conducted<sup>8</sup> reversed water sprays resulted in greater respirable dust efficiency while still being able to clean the screen effectively. A combination of screen-directed and reversed water sprays will provide the most efficient system, optimizing both the scrubbing and the cleaning effects.

#### (d) Demisters

Mist elimination is effected by demisters which are used to eliminate water droplets from the gas stream. They operate primarily through inertial impaction, but interception and diffusion could play an integral part as well.

The most common types of demister in use are the baffle and mesh demisters. In mining the zig-zag baffle-type demister is used predominantly. Liquid face-separation chambers are used to eliminate the carry-through of water droplets.

The principal designs are shown in Figures 6.6 and 6.7.

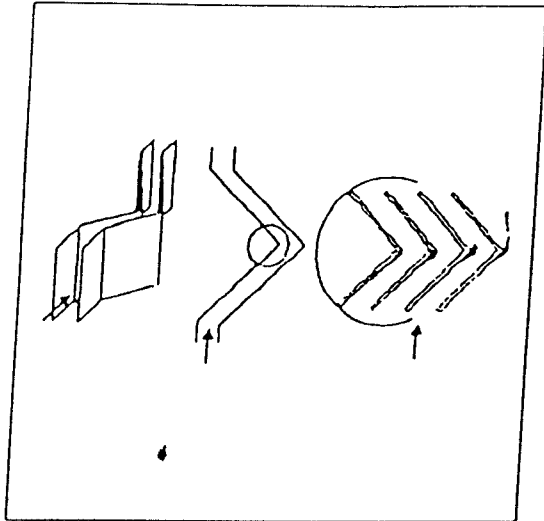

Figure 6.6 Demister baffle design

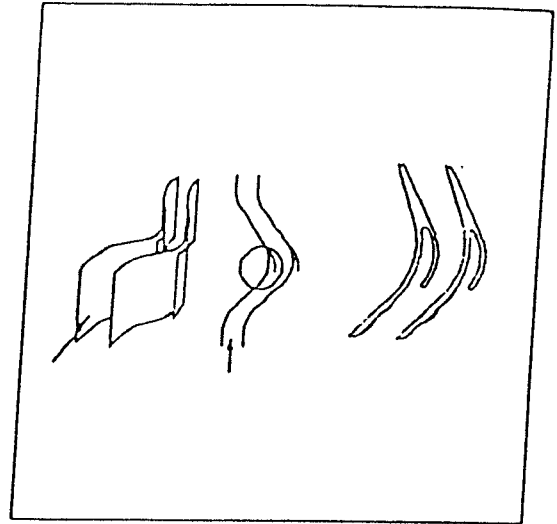

Figure 6.7 Phase separation

A third type of mist eliminator is the mesh mist eliminator.

This can be installed from 0-45° to the horizontal and the thickness of the screen varies from 100 to 300 mm. Water sprays are used to clean the screens at set time intervals. The efficiency of droplet removal will decrease as velocities change in either direction away from the design velocities.

Table 1 shows the reported velocities for horizontal (aerosol flow direction) mist eliminators

TABLE 6.3  
MIST ELIMINATOR VELOCITIES

ELIMINATOR TYPE	GAS VELOCITY (m/s)
Zig-zag	4,6 - 6,1
Zig-zag (30° from horizontal)	4,9 - 6,7
Mesh	4,6 - 7,0

Chevron mist eliminators with horizontal gas flows have a 99% effectiveness for  $F_1$  factors ranging from 1,2 to 4,8

The  $F_1$  factor is determined as follows:

$$F_1 = V_g (\rho_g)^{0.5} \dots\dots\dots 6.5$$

where  $V_g$  - superficial gas velocity (ft/s)

$\rho_g$  - gas density (lb/ft<sup>3</sup>)

The importance of gas velocity is that it has a predominant influence on the effectiveness of the scrubber and the re-entrainment of water droplets back into the air stream. Re-entrainment is defined here as the "stripping of liquid back into the gas stream".

✂

Re-entrainment depends on:

- mist eliminator configuration and position
- gas velocity
- entrained wash liquid
- liquid drainage rates.

The mist droplets that enter are generally relatively large (50-500  $\mu\text{m}$ ), although much smaller droplets will also be present. The mechanisms for the removal of droplets from the gas stream are:

- impaction
- interception
- sedimentation
- centrifugation
- electrostatic precipitation.

Re-entrainment of captured particles will be caused by one of the following mechanisms:

- transition of liquid from the liquid phase to entrained flow
- rupture of bubbles
- creeping of liquid on the separator surface
- shattering of drops on impaction.

The question of what impact higher velocity has on effectiveness can now be answered. At higher velocities there is an increase in the impaction removal of droplets, but re-entrainment increases and will eventually dominate.

Calvert<sup>11</sup> et al predicted values for the maximum gas velocities needed to prevent

excessive re-entrainment. In zig-zag (louvre) baffles the re-entrainment depends strongly on the liquid drainage rate and, thus, the orientation of the baffles is a variable.

In horizontal demisters re-entrainment becomes excessive with gas velocities exceeding 5 m/s at liquid-to-gas ratios of 1 l/m<sup>3</sup>. Gas velocities can be increased at lower liquid-to-gas ratios without excessive re-entrainment.

Reducing sharp angles of baffles to the airstream should reduce re-entrainment, e.g. baffles at 30° to the airflow direction will cause less re-entrainment than baffles at 45° to the airstream.

In mesh mist eliminators the maximum gas velocity ( $V_g$ ) needed to prevent re-entrainment can be estimated using the Souders-Brown equation:

$$V_g = 30,5 C_1 \frac{\sqrt{\rho_l \rho_g}}{\rho_g} \dots\dots\dots 6.6$$

where  $V_g$  - maximum allowable gas velocity (m/s)

$C_1$  - empirical constant

$\rho_l$  - liquid density (g/cm<sup>3</sup>)

$\rho_g$  - gas density (kg/m<sup>3</sup>)

Except with the mesh mist eliminator, the pressure drop in a mist eliminator does not seem to vary considerably with orientation or the amount of liquid entrainment.

### 6.4.3 Scrubber operation

The effectiveness of scrubbers in minimizing the amount of airborne dust in a workplace (or mine) is also influenced by various other operational factors. These include the type of ventilation used, the water spray system used, the position of scrubber inlet and the face airflow pattern.

The effectiveness of dust-control techniques can differ at various locations in the face area. Therefore, the choice of a dust-control system should be based on an evaluation conducted at the location where it is to be employed<sup>12</sup>.

It is recommended by the USBM<sup>12</sup> that for optimum dust-capture efficiency, the fresh air supply to an entry should equal the quantity that can be handled by the scrubber.



## **7 WATER APPLICATIONS**

7.1	Planning Requirements	62
7.2	Main Water Supply	62
7.3	Machine Water Supply	64
7.4	Water Sprays	64
7.4.1	Mechanics of water-spray dust suppression	64
7.4.2	Spray characteristics	66
7.4.3	Design considerations	66
7.4.4	Spray selection and nozzle types	67
7.4.5	Venturi sprays	70
7.4.6	Special sprays	71
7.4.7	Wetting agents	71
7.5	Water Filtration	71
7.6	Scrubbing Systems	72
7.6.1	Flooded-bed scrubber	72
7.6.2	Water-powered scrubbers	73
7.7	Summary	73

## 7. WATER APPLICATIONS

### 7.1 Planning Requirements

Water can provide an economical and effective means of controlling dust in a continuous miner section. It is important, however, that the water supply system be carefully designed during the planning stage. Water requirements should be considered in the same light as other parameters of dust control such as ventilation, materials handling, and coal transport. Although existing water quantity and pressure may be considered adequate for dust suppression purposes, these would be inadequate if pipeline distances and numbers of machine sections were to be increased in the future(3).

Research is currently being carried out by the Chamber of Mines Coal Mining Laboratory in examining water reticulation systems, both quantitatively and qualitatively. In addition, water flow network simulation programs are being utilized which will eventually play a role in the planning of reticulation systems.

The following sections deal with specific components of the reticulation network. A worked example, using nomograms and formulae, is presented in Appendix I.

### 7.2 Main Water Supply

Water used in coal mines is generally obtained from a surface supply, although a number of mines do recycle a certain amount of water. In areas where water is in short supply, or where the cost of water is excessively high, recirculation may be considered as an alternative means of supply.

Due to the relatively shallow working depth of collieries in South Africa, the pressure developed by gravity-feed alone may not be sufficient to meet the demand of dust suppression systems in use (see Figure 7.1). In these cases booster pumps are installed to provide adequate pressure and flow. The site and type of booster pump required depends on two factors:

- (i) the available pressure at the machine, once pressure losses in the reticulation system have been taken into account
- (ii) the required pressure and flow rate at the machine.

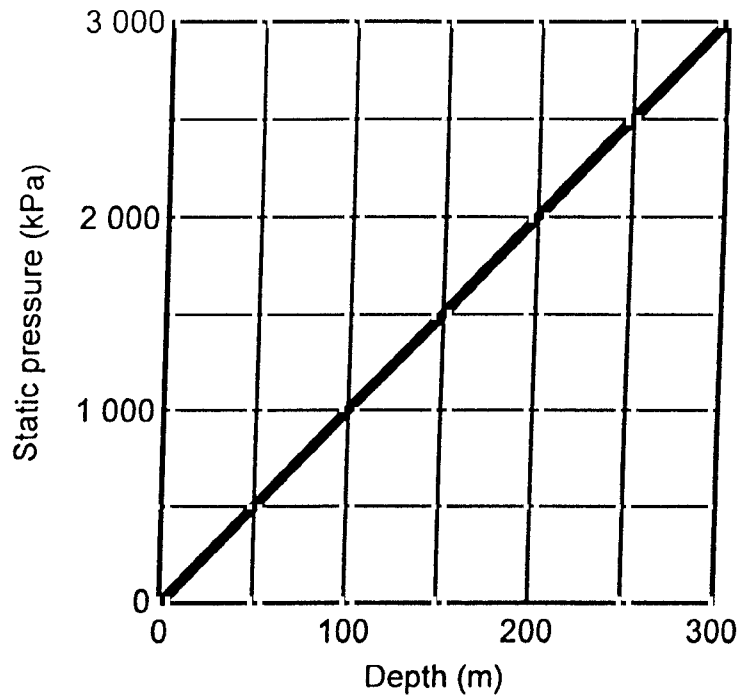

Figure 7.1 Nomogram for determining of static pressure at a given depth of mining

Pressure losses will occur in the pipe network, and these will increase as the distance of working from the shaft bottom increases. These losses can, however, be minimized by the correct selection of the main water piping. A nomogram (Figure 7.2) shows how pressure losses may be determined for various schedule 40 pipe diameters at specified flow rates (6). (A schedule 40 pipe has specific wall thickness and internal diameter (4)).

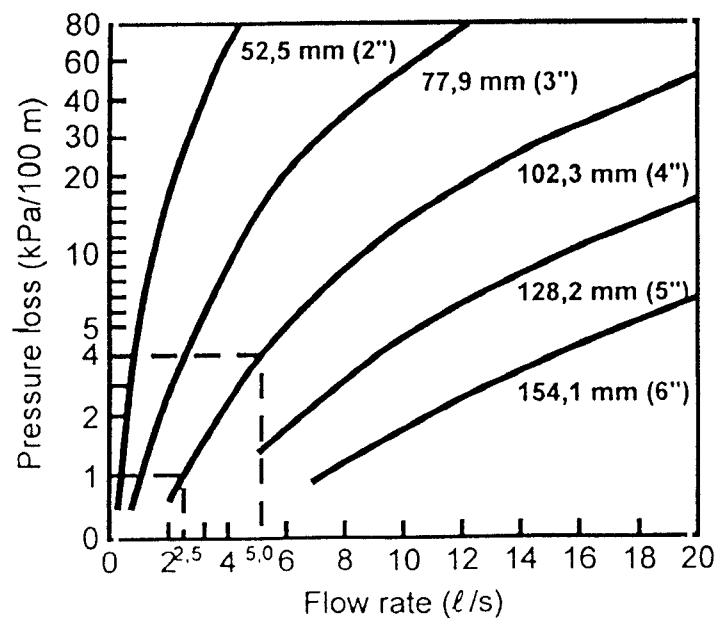

Figure 7.2 Nomogram for determination of pressure losses (per 100 m) at given flow rates in schedule 40 pipes

## 7.3 Machine Water Supply

Water pipes and hoses should, of course, be selected to meet the greatest likely demand of machine sections, since quantities and pressures may vary, depending on the machine type and on the dust suppression system in use.

Water is delivered to the machine by means of a trailing water hose. Large pressure drops can occur in this area if the correct diameter hose is not used. A damaged hose must always be replaced immediately.

Figure 7.3 shows the pressure drop incurred for specific hose diameters at various flow rates. Although the selection of a smaller hose may lead to a cost saving in the short term, the limiting effects of such a hose would be detrimental to the suppression system in use. Generally, depending on the flow rate, a 38,1 mm or 50 mm internal diameter hose would be the best for use on continuous miners (5, 7).

## 7.4 Water Sprays

### 7.4.1 Mechanics of water-spray dust suppression

Water sprays suppress respirable dust in two distinct ways:

- (i) they wet coal surfaces so as to immobilize newly-formed dust and prevent it from becoming airborne (this is termed 'impaction'), and
- (ii) the water droplets collide with and engulf airborne dust particles, enabling them to settle from the airstream (this is termed 'airborne collection').

It is considered more effective to suppress dust by wetting coal surfaces, rather than by allowing the dust to become airborne. The mechanics of both processes are covered in more detail in the literature (8, 9).

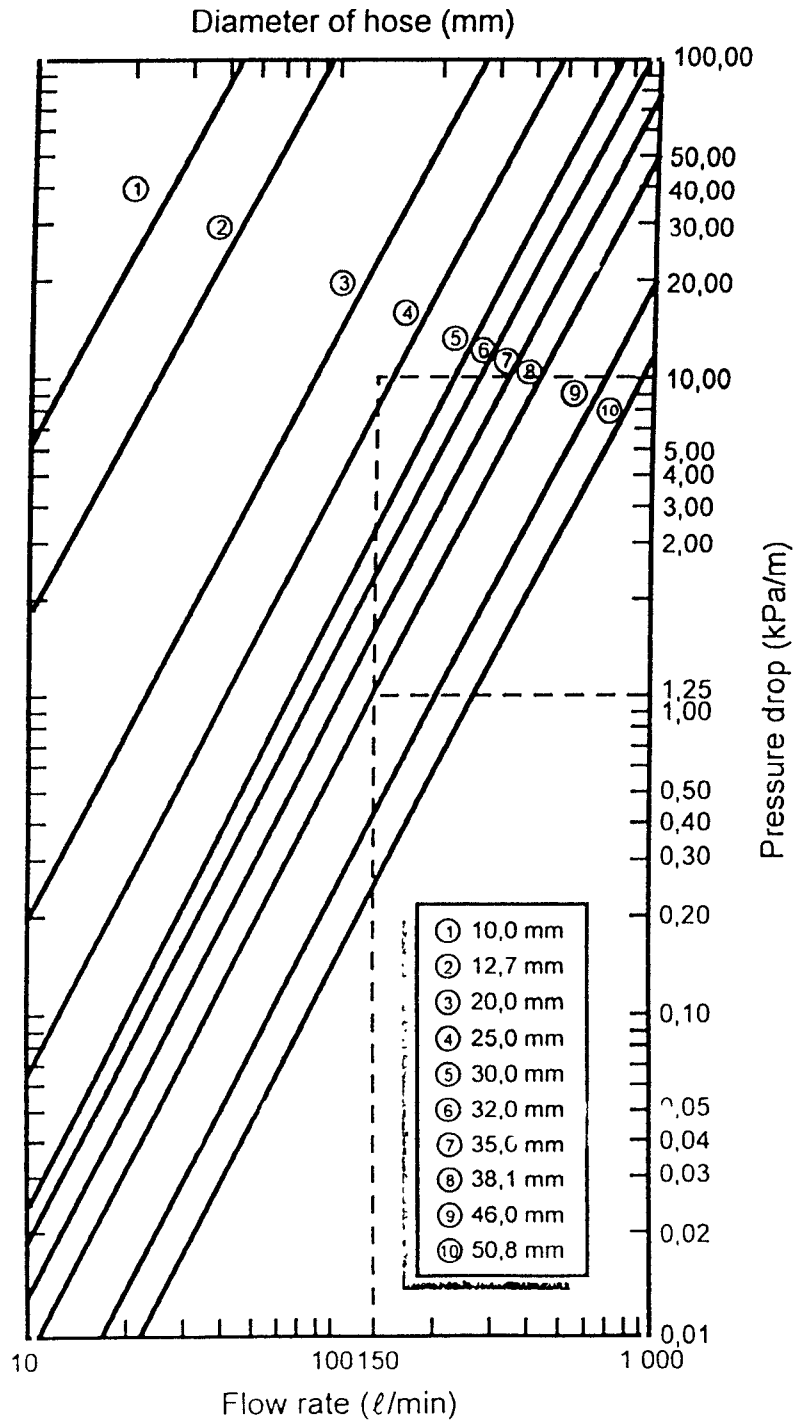

Figure 7.3

Nomogram for determination of pressure drops at a given flow rate in trailing water hoses of various internal diameters

### 7.4.2 Spray characteristics

A number of optimum spray characteristics are given below; the literature (2, 10) provides further information.

- (i) Coal-wetting efficiency is maximized if spray nozzles deliver high-velocity droplets of approximately 500 microns in diameter. This is the most effective droplet size for the impaction of dust particles.
- (ii) Smaller diameter droplets (about 200 microns) are more effective for the capture of airborne respirable dust.
- (iii) Droplet velocities can be maximized by selecting appropriate nozzles and/or increasing nozzle operating pressure. Droplet size for a given nozzle decreases with increasing pressure. However, care should be taken that the pressure is not increased to the point that droplets are so small that they are quickly slowed down by friction, and become ineffective.
- (iv) Both processes, impaction and airborne collection, are enhanced by increasing the flow rate of the water supply.
- (v) Airborne dust capture efficiencies are affected by local airflow patterns and the entrainment of air by the water sprays. Local ventilation conditions should be examined, with respect to the positioning of sprays (Section 4 and 5).

### 7.4.3 Design considerations

The performance of sprays in field applications is influenced by a number of parameters, knowledge of which is essential for the operator (For the purpose of these guidelines, 'operator' refers to senior technical staff). Although criteria exists for the optimization of impaction and airborne collection processes, firm standards for spray configurations and operating parameters are difficult to define. However, the following considerations for spray selection are applicable generally.

- (i) Where is dust generated? The operator should identify the main areas of dust-generation, e.g. cutting head, conveyor throat, and transfer points.
- (ii) What type of suppression-process, impaction or airborne collection, is necessary? For example, at the cutting head, impaction is probably the main dust suppression mechanism.
- (iii) Constraints on the system:
  - the possibility that too much water may result in bad floor conditions
  - possible limits set by the preparation plant on the quantity of water in the coal
  - availability of sufficient water quantity and pressure
  - effects of sprays on personnel
  - poor water quality necessitating the use of filters to prevent nozzle clogging

These considerations must be examined, before the operator selects the spray configuration best suited to his particular operation.

#### 7.4.4 Spray selection and nozzle types

As every operator is aware, there are a bewildering number of nozzles available.

Some of the most common designs are described below and shown in Figure 7.4.

- (i) *Hollow cone* : spray droplets are smaller and the spray angle is wider relative to other types of nozzles. These are useful where dust is widely dispersed e.g. transfer points.
- (ii) *Full cone* : the droplets are higher in velocity than other sprays. They are useful in providing a high velocity spray where the nozzle is located at a distance from the area where dust suppression is desired. These are frequently applied at the cutting face.
- (iii) *Flat* : the droplets are generally large compared to other sprays and are delivered at high velocity. This type of nozzle is frequently used as a side spray on continuous miners.
- (iv) *Venturi sprays* : these are suggested for the conveyor throat to prevent dust dispersion over the operator.

It is not the purpose of these guidelines to promote a particular brand of nozzle or any specific supplier. However, Table 1 is included to illustrate a range of nozzles giving the type of information which would assist an operator in the selection of a spraying system.

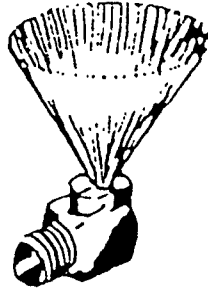

A. HOLLOW CONE

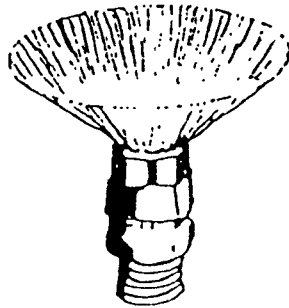

B. FULL CONE

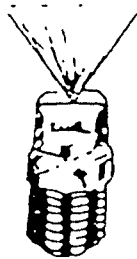

C. FLAT

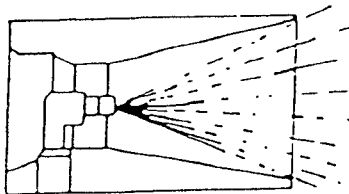

D. VENTURI NOZZLE

Figure 7 4 Various nozzle types



TABLE 1  
EXAMPLES OF OPTIMUM SPRAY NOZZLES FOR DUST CONTROL

Coverage distance (m)	Type	Orifice diameter (mm)	Optimum line pressure (kPa)	Flow rate per nozzle at optimum line pressure (l/min)	Spray angle (°)	Drop size (μm)
<b>Airborne Collection</b>						
1,8	Hollow Cone	2,4	700	3,5	78	220
1,1	Hollow Cone	3,3	300	3,8	70	340
1,4	Full Cone	1,2	1 400	3,4	32	240
1,8	Full Cone	1,2	1 050	2,9	40	340
<b>Impaction</b>						
0,8	Full Cone	1,2	600	2,1	46	470
0,9	Full Cone	1,6	1 000	4,6	40	480
1,2	Full Cone	1,6	350	2,8	48	880

From Table 1 it can be seen that, if the nozzle in an impaction process (e.g. at the cutting head) is 1,2 m from the target surface and minimal water is desired, a full cone nozzle should be operated at 350kPa and located in such a way that the spray angle of 48° gives the proper coverage. If a smaller spray angle is desired and water flow is less important, a full cone nozzle could be operated at 1 000 kPa at 4,6 l/min.

Table 1 also indicates that optimum sprays can be obtained with line pressures as low as 400 kPa, albeit for limited applications. Generally, however, line pressures should be in the region of 700 - 1 400 kPa. To ensure this, available flows should be effectively utilized, and, for example water should not be fed to a spray block, where little or no dust is present in the vicinity. This can be a problem when a machine is received from the manufacturer, as typically, 21 to 40 sprays are used on continuous miners, often in positions where they are not needed. In these instances, therefore, certain sprays must be removed from new machines, because an adequate water pressure cannot be maintained to provide a sufficient flow rate for each nozzle.

For conventional spray systems, a flow rate of between 90 and 150 l/min is normally sufficient. Obviously, individual requirements depend on the factors discussed in 7.4.3.

Typical spray positions on a continuous miner are shown in Figure 7.5.

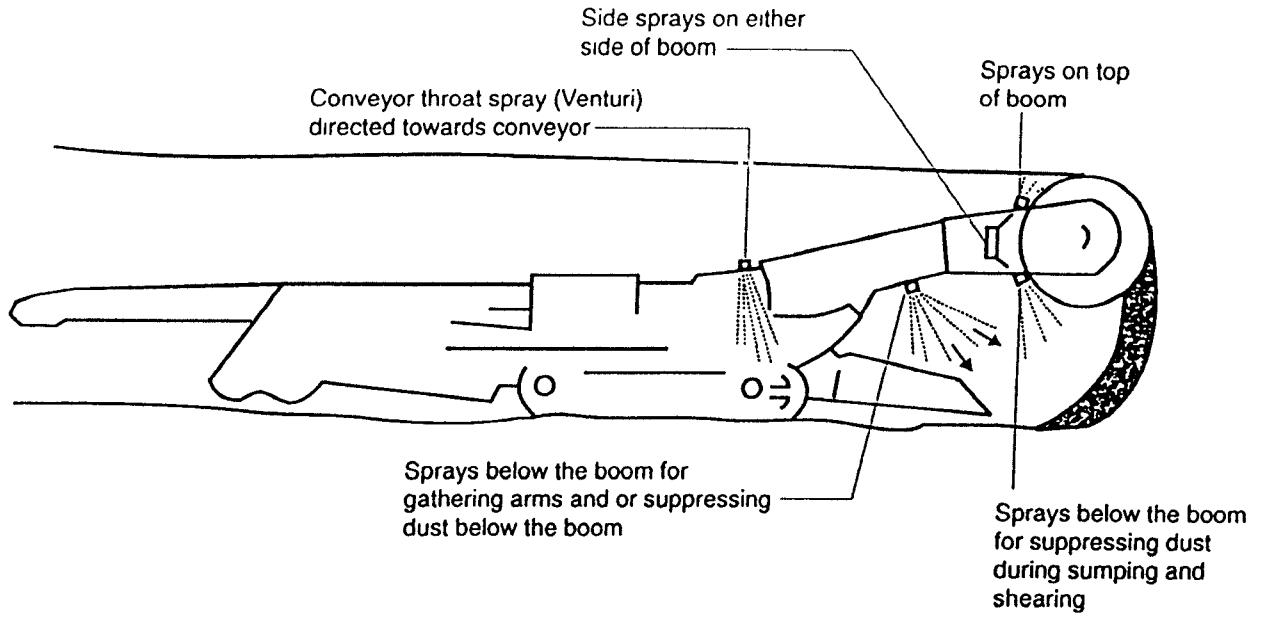
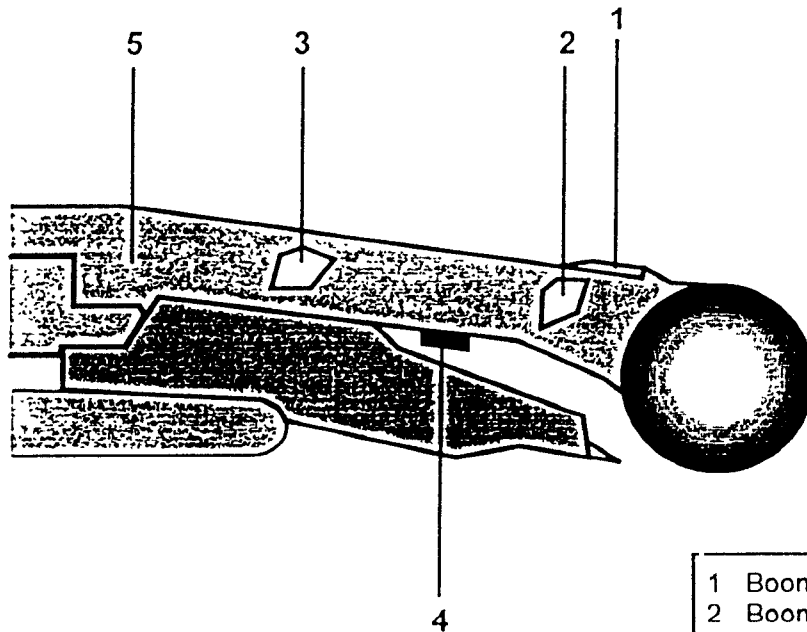

Figure 7.5 Typical spray positions on a CM

### 7.4.5 Venturi sprays

Research has indicated that venturi-sprays can significantly improve dust suppression by creating uniform, highly directable water spray patterns. In addition, venturis are able to move large quantities of air, enabling the dust suppression system to fulfil a role of auxiliary ventilation. As seen in Figure 7.4 the unit consists of a spray nozzle centrally mounted in a venturi-shaped enclosure. The resulting spray is more finely atomized, giving the same volume of water considerably more wetting potential. The spray can also be directed further than conventional sprays. The literature (11,12) gives more detailed information on venturi sprays.



1	Boom: Front-top	2 off
2	Boom: Front side	2 off
3	Boom: Rear-side	2 off
4	Under boom	2 off
5	Above conveyor	1 off

Figure 7.6 Typical venturi dust suppression system

#### **7.4.6 Special sprays**

##### **(a) Pneumatic sprays**

The pneumatic spray mixes high-pressure air with water in a plenum chamber. The air-water mixture is then passed through a nozzle to form a spray of very small drops. The collection efficiency of a pneumatic spray has not been reported, but is probably not very high due to the fact that waterdrops quickly lose their momentum, and give a low relative velocity between a drop and dust particles. An additional difficulty is the provision of an auxiliary high-pressure air system, and hence increased maintenance.

##### **(b) Electrostatic sprays**

Electrified sprays reportedly reduce airborne respirable dust significantly when compared with ordinary sprays. However, these sprays have not been proven to be intrinsically safe in an underground environment, and therefore cannot as yet be considered.

##### **(c) Foam**

Field tests applying low-expansion foam have shown a 50 % increase in efficiency over conventional sprays. However, the inconvenience, the high cost of foam and the possibility of refoaming occurring in a washing plant limits its use in practice.

#### **7.4.7 Wetting agents**

Wetting agents are additives which are mixed with water to enhance its ability to adhere to coal dust. Field tests have been carried out for many years in the USA, and results have shown an increase of 10 to 15 % in collection efficiency compared to using water alone. However, for this moderate increase in efficiency, the expense and the possible corrosive effects of wetting agents on, amongst others, pipes and cooling jackets must be considered. Further research should indicate the potential of using wetting agents.

### **7.5 Water Filtration**

A major problem associated with the use of water spray systems for dust control is the frequent clogging of spray nozzles. A clogging nozzle is quite useless, as is a partially plugged nozzle since it destroys the spray pattern. Either condition greatly reduces the dust suppression effectiveness of a spray system.

Nozzles clog primarily because of pipe scale, or coal or rock particles in water lines. Occasionally, external clogging occurs when the water pressure is not sufficient to prevent material from lodging in the nozzle outlet. In order to minimize the potential for nozzles to clog, the orifice diameter of the nozzle should be greater than or equal to 0,9 mm. Individual filters for each spray nozzle can be used to reduce clogging. These should have a mesh size of no greater than half of the nozzle orifice diameter. However,

if used alone, frequent cleaning and replacing of these filters can become time-consuming and costly. It is therefore preferable to use these filters in a supplementary role, in conjunction with a more extensive filtration system. A number of filtration systems are available, including a non-clogging water system. Details are given in the literature (13,14,15).

An important development has been the introduction of an independent reticulation system for sprays. Thus, if sprays become clogged and water flow impeded, there is no possibility of machine motors becoming overheated.

## 7.6 Scrubbing Systems

A number of scrubbing systems are currently in use worldwide, and various conclusions have been reached as to the effectiveness of each system. This section deals with some of the principles involved in scrubbing dust-laden air. Further technical information is given in the literature (16 - 26) for assistance when selecting a system. Section 4 describes the relevant auxiliary ventilation used with individual scrubbing systems.

### 7.6.1 Flooded-bed scrubber

Figure 7.7(a) shows a schematic of the scrubbing mechanism in a flooded-bed scrubber, and Figure 7.7(b) depicts a plan view of the complete installation.

Flooded-bed scrubbers comprise a pad of metal mesh or fibres, through which dust-laden air is drawn. A water spray directed at the face of the pad wets the fibres to enhance the capture of dust by water droplets and flushes away captured dust particles. Dust is collected by inertial impacting of the dust particles onto the wetted surfaces of the fibrous pad.

Dust-laden air is picked up at three inlets, which are approximately 1,8 m to 2 m from the face depending on the type of machine. The air is transported back in separate channels to the common duct on the left hand side of the machine. The pressure drop across each of the three channels controls the amount of flow drawn by each inlet. The inlets are generally balanced so that the flow through each is approximately the same.

The ductwork has a number of components. The front section is mounted rigidly on the cutter head boom. At the hinge point of the cutter head boom is a telescopic joint which is hinged at both ends, allowing for raising and lowering the boom when cutting.

The scrubber assembly is mounted in the ductwork immediately behind the telescopic joint. It has an access panel for the scrubber screen, and this assembly can be quickly changed when necessary. Upstream of the scrubber screen is a manifold containing the water nozzles which supply water to the flooded bed at a rate of approximately 20 l/min at 960 kPa

After passing through the scrubber screen assembly, the air is diverted downwards, and expanded into the demister housing. The water droplets entrained in the air lose their momentum and fall into a sump which is connected to the machine conveyor by a drain. Once through the demister housing, the clean, dry air enters the fan and is discharged. Normally a vane axial fan is used, driven by an 18 kW electric motor

## 7.6.2 Water-powered scrubbers

The system illustrated in Figures 7.8 (a) and 7.8(b) uses a series of high pressure water sprays both to induce airflow and to perform the scrubbing action. The scrubber contains no fan or screen and is totally contained within the cutter boom frame of the continuous miner. It is self-cleansing, except for the water sprays, and is virtually maintenance free. Figure 7.8 (a) depicts a water-powered scrubber in use on some continuous miners in South Africa. The scrubber is situated on the cutter boom assembly, and on either or both sides of the machine. The dust-laden air is drawn into the scrubber assembly, as shown, the air mixes with water droplets which capture the dust which is then blown out of the central unit towards the cutter head. The side unit, of smaller capacity, directs airflow away from the face on the opposite side to the driver.

Figure 7.8 (b) shows a water-powered scrubber (16) developed in the USA, which uses the same principles of scrubbing as the one previously discussed, but is located differently on the machine. The pressure and water requirements are 3 10 kPa at 150 l/min. This system consists of a centre throat unit which is mounted between the boom legs and either a left side or right side unit or both, depending upon the direction of face ventilation.

Once the dust-laden air is mixed with water droplets, the water/dust droplets then pass into a low restriction eliminator which removes the droplets from the airstream. The air discharged from the rear of the eliminator is clean and dry. The slurry from the mist eliminator flows onto the conveyor where it mixes with the coal and is loaded out. The advantage of this system is that it allows the intakes to be located to the face, capturing the dust as soon as it is generated.

## 7.7 Summary

Water reticulation systems should be planned well in advance so as to reduce the possibility of shortfalls in both water quantity and pressure.

Water pipes and hoses should be selected to meet the greatest demand of machine sections. Pressure losses can be minimized by selecting the correct diameter and type of piping and hosing. Trailing water hoses can cause significant pressure losses; hence the selection of the hose may be critical when determining booster pump requirements.

Leakages in the system will also cause unnecessary pressure and flow losses, as well as create poor floor conditions.

Correct selection, positioning and maintenance of spray systems are essential if they are to be effective. Even so, studies have indicated that conventional spray systems are not as efficient as scrubbing systems in terms of dust suppression (27).

Dirty water may cause sprays to clog, and cause corrosion problems in water jackets on machine motors. Filters, therefore, are an essential component in the reticulation system.

Scrubbing systems are used to remove dust from the air, and in some cases promote airflow. However, an effective ventilation system, if properly maintained, will dilute airborne dust, thus reducing the efficiency requirements of a scrubbing system.

## **8 VENTILATION**

8.1	Introduction	74
8.2	Definitions	74
8.2.1	Air recirculation	74
8.2.2	Air re-inducement (re-entrainment)	75
8.2.3	Fresh air entrainment	75
8.2.4	Turbulence	76
8.3	Ventilation to Remove or Dilute Dust	76
8.3.1	Basic characteristics of airflow	76
8.4	Section Ventilation Systems	79
8.4.1	Coursing Cantillation	79
8.4.2	Splitting ventilation	81
8.5	Mechanical Miner Bord & Pillar Development	81
8.5.1	Different ventilation systems	81
8.5.2	Some basic recommendations to be considered when installing various ventilation systems	89
8.5.3	Airjet fans	90
8.5.4	Ventilation of bord & pillar split development	93
8.6	The Ventilation of Stopping Sections	103
8.6.1	Pillar extraction	103
8.6.2	Rib-pillar extraction	107
8.6.3	Discussion	111

## 8 VENTILATION

### 8.1 Introduction

The mechanisation of the coal mining industry has resulted in the generation of more coal dust during cutting operations. The emphasis on the use of mechanical miners has prompted the Department of Mineral and Energy Affairs to introduce an industry guideline to ensure the adequate ventilation of mechanical miner sections. Incorporated into these guidelines are various suggested ventilation and dust control systems all of which are aimed at limiting the dust levels at the operators position to  $5,0 \text{ mg/m}^3$ .

This chapter aims to introduce the latest technology used to evaluate the ventilation and dust control systems, and stems from research undertaken in recent years to improve the understanding of the dynamics associated with the ventilation of large coal mining headings.

### 8.2 Definitions

Throughout this document, certain terms and terminology will be used, and to prevent confusion, the following definitions are given.

#### 8.2.1 Air recirculation

This is when the air, which has originally been delivered by an auxiliary force ventilation system, re-enters the intake of that system (see Figure 8.1)

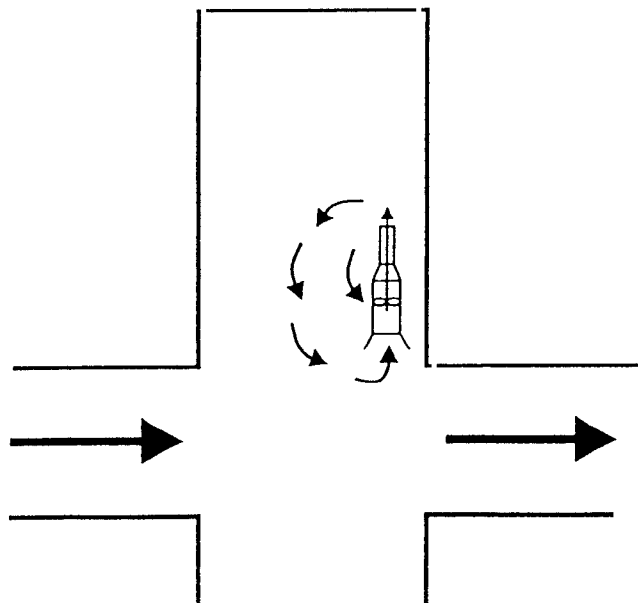

Figure 8 1

### 8.2.2 Air re-inducement (Re-entrainment)

Refers to air, after it has been delivered into the heading, which flows back from the face towards the last through road. It is then pushed back into the main airstream. This phenomenon is usually caused by air velocity discharging from a fan and does not include air classified as recirculation (see Figure 8.2).

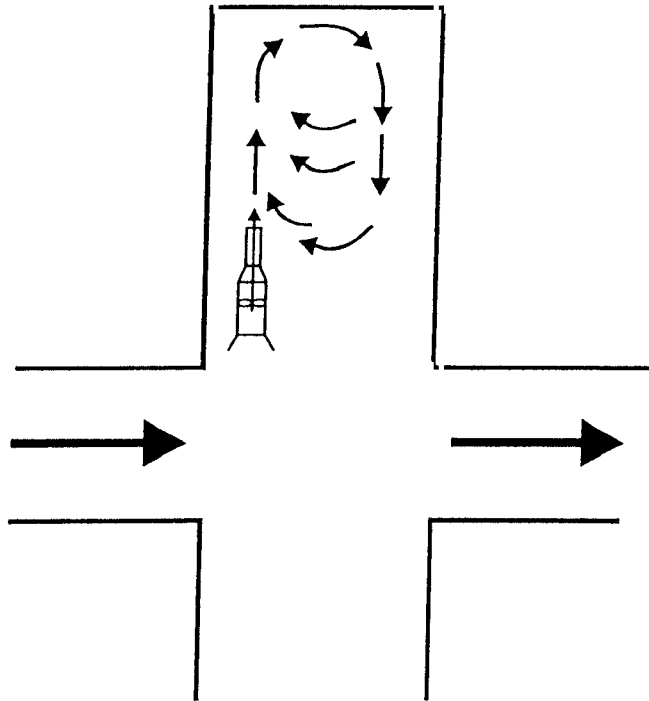

Figure 8.2 Sketch showing the definition of air reinducement

### 8.2.3 Fresh air entrainment

Apart from air delivered by a fan, additional fresh air can be pulled into the heading as a result of the thrust action of the air velocity. It does not include any air recirculation (see Figure 8.3).



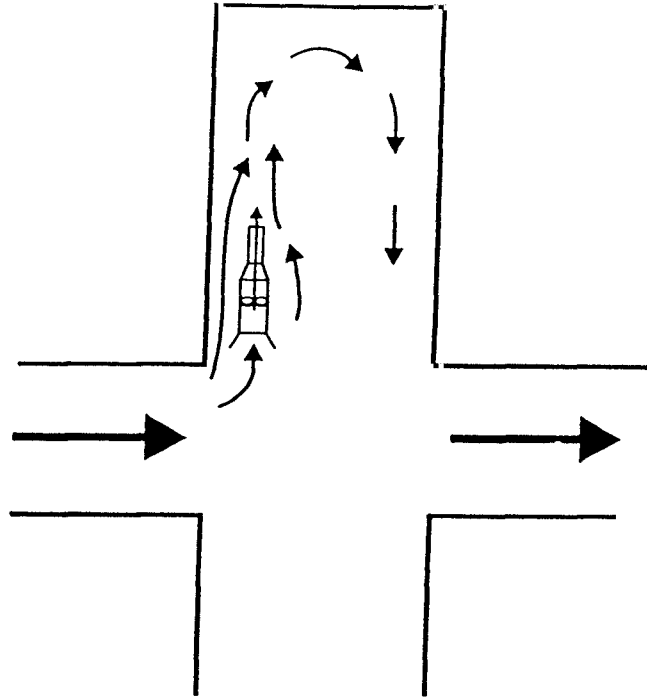

Figure 8.3 Sketch showing the definition of fresh entrainment

#### 8.2.4 Turbulence

Turbulence can be classified as the three-dimensional airflow phenomenon which occurs inside the heading. It is caused by the interaction between the tunnel sides and high air velocities generated by the force fan outlets.

### 8.3 Ventilation to Remove or Dilute Dust

#### 8.3.1 Basic characteristics of airflow

For air to flow in an airway there must be a difference in pressure, which is usually generated by the main fan system. The direction of the air in the last through road (LTR) is dictated by the layout of the section, as well as the auxiliary ventilation system. The LTR air velocity plays a dominant role in the effectiveness of the ventilation system, which in turn contributes to the removal and dilution of the dust generated in a heading.

Air flowing past a heading in the LTR enters the heading on the opposite ("downstream") side of the heading (Figure 8.4). This is normal, when the heading is empty and there is no auxiliary ventilation present which could influence this behaviour.

The maximum penetration distance is determined by the air velocity flowing in the LTR and the seam height\*. At a velocity of between 1,0 m/s and 1,4 m/s and a seam height of approximately 3,0 m, the air will penetrate to  $\pm 12,0$  m (1). This penetration distance changes when all the ventilation systems and machinery are in place inside the heading and the production cycle commences.

Tests have shown that when auxiliary ventilation systems are used, they should be installed on the upstream side of the heading, opposite from the side that air would tend to enter the heading to ensure no air recirculation.

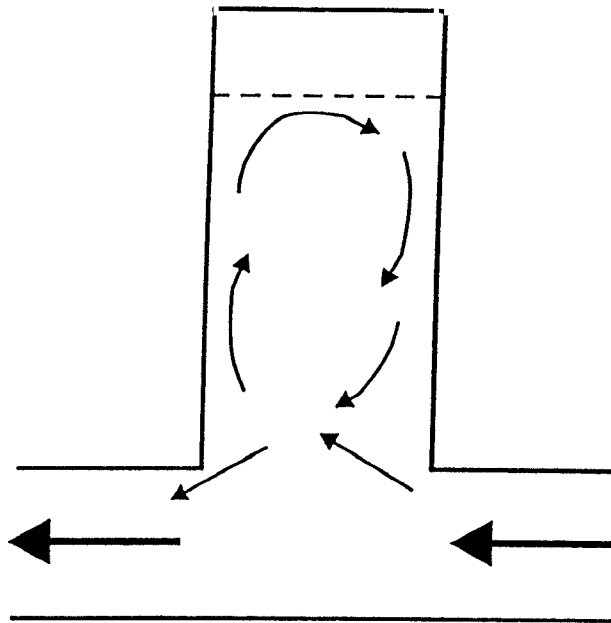

Figure 8.4 Sketch showing the normal behaviour of air when flowing past an empty heading

Figure 8.5 and 8.6 show the difference in air flow behaviour when a fan is installed upstream and downstream in the entrance of the heading. The auxiliary ventilation force systems should also not be installed on the same side as the on-board scrubber for obvious reasons.

The different seam heights at which mining is conducted plays a major role in the behaviour of air, and the type of ventilation system which should be used to control dust. Research which has been conducted on the effect of different seam heights on airflow patterns, indicates the following:

- i) *Medium to low seams (2,0 m - 3,0 m)*: the air tends to flow more in a two dimensional manner. There seems to be a definite line between air flowing into the heading and air flowing out of the heading. This can influence air penetration distances when a system such as the jet fan is used<sup>5</sup>. The air turbulence levels can be high, when an on-board scrubber with a sprayfan system is used. This is good for methane control, but tends to negate dust control measures.
- ii) *Medium to high seams (3,0 m - 4,0 m)*: the ventilation flow patterns are less restricted and turbulence thus lower. Consequently a better balance between the ventilation force and the on-board scrubbing system is obtainable that complements dust control.

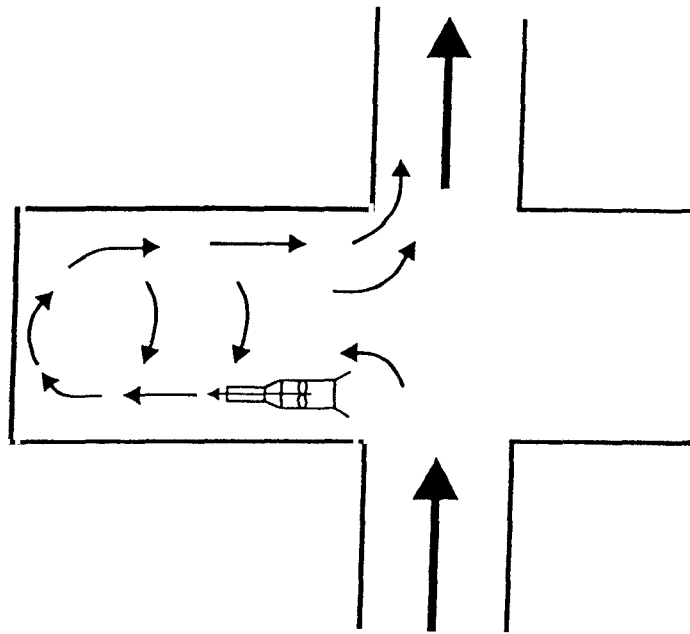

Figure 8.5 Airflow patterns with a fan installed upstream

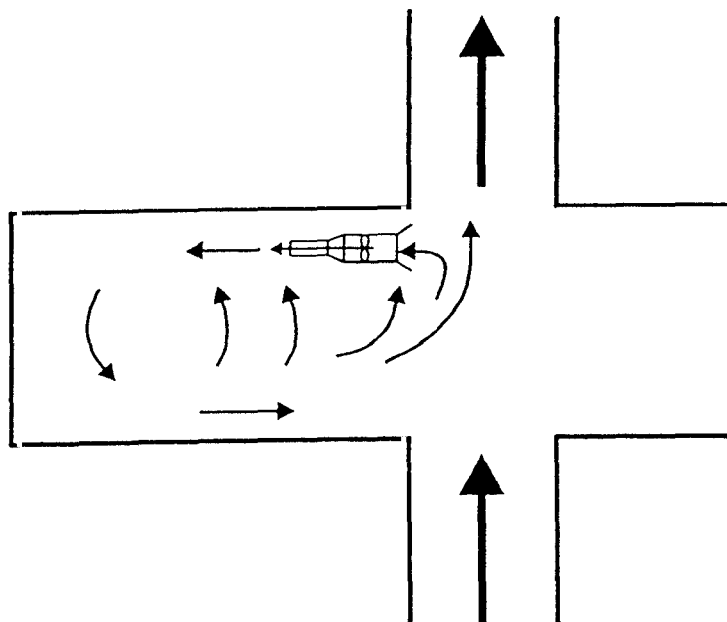

Figure 8.6 Airflow patterns with a fan installed downstream

iii) *Ultra high seams (75,0 m)*. cause complications as the air is now forming in areas where little or no airflow is present, and this can impede methane control. Ventilation systems which can be used in high seams which are able to create sufficient turbulent levels, must be considered. In these high seams, the air flow against the roof behaves differently from the air flowing through the rest of the heading, with a tendency to encourage the formation of methane layering. The low turbulence levels are, however, excellent for dust control

Turbulence and air recirculation patterns inside a heading, are generally not good for dust control and should be kept to a minimum. It should also be remembered turbulence and recirculation patterns dilute methane, and high air velocities in and out of the heading will

control this hazard. For this reason, the airflow patterns in the heading should be controlled in such a manner to address both the methane and dust. By understanding the effect of ventilation systems on airflow and by balancing the quantities, this can be achieved, ie. by having a positive flow of fresh air over the drivers position towards the face position. At this position the air velocity is said to be not less than 0,4 m/s to prevent dust rollback<sup>6</sup>. Once the air reaches the face, the general direction of the airflow should be from the drivers side of the face to the scrubber side of the face. From this position, the air should flow towards the LTR, either through an on-board scrubber system or through an exhaust system, or as a result of sufficient energy introduced into the face by a force system.

## **8.4 Section Ventilation Systems**

Two basic systems are in use in bord and pillar mining. These are the splitting and coursing methods.

### **8.4.1 Coursing ventilation**

In this section the air flows into the section via the intake roads on one side of the section. The air is directed and controlled to the LTR by means of walls and brattices. Once the air reaches the LTR, it flows past the headings towards the return roads on either side of the section (Figure 8.7).

The main advantage of this system is that the air is concentrated and can be maintained in the LTR. Another positive aspect of this system is that only one row of walls is needed for controlling the ventilation.

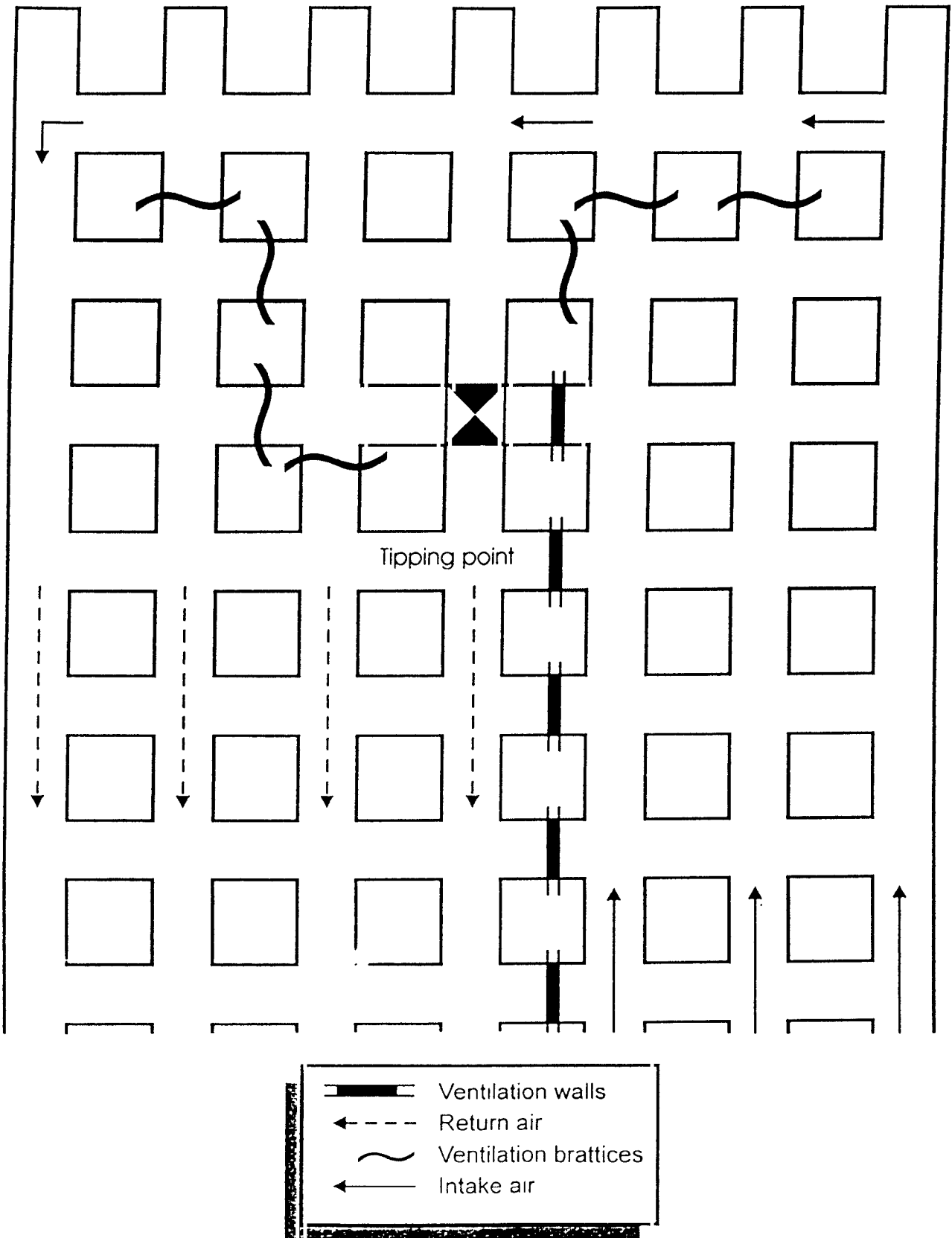

Figure 8 7 Section ventilated by the coursing method

A disadvantage of the system is the possibility of contaminated air being carried from one heading into the next, exposing the people working downstream to this contamination. This system is, however, recommended where auxiliary fans such as jet fans are used in the LTR.

#### **8.4.2 Splitting ventilation**

Air flows into the section via the intake airways situated in the centre of the section. When the air reaches the LTR, the air splits and flows towards the return airways on either sides of the section (Figure 8.8). Two rows of walls and brattices are needed for ventilation control which results in higher costs and more air leakage.

This ventilation system creates an unventilated area in the middle of the LTR, which can result in methane build-up and even the recirculation of the fans when installed in these areas. Because the auxiliary fans should always be placed in the upstream position of a heading and the mechanical miner operator should always be placed on the opposite side, the use of this ventilation system may prove to be impractical. For this reason, it is not recommended for use in bord and pillar development.

### **8.5 Mechanical Miner Bord and Pillar Development**

Different ventilation systems are in use throughout the industry depending on individual needs and requirements. However, the main objective of all systems is to create a healthy environment on the working face and this can only be achieved by the effective removal and dilution of dust and gases. This includes dealing with the large amounts of dust created by the mechanical miners. Methane could be present and ventilation systems should be designed to address both contaminants. To date water sprays and wet scrubbers are generally used in conjunction with different ventilation systems.

#### **8.5.1 Various ventilation systems**

A general description is given on the different ventilation systems available for use, after which recommendations on the effective uses of these systems will be given. The use of air jet fans will be dealt with under a separate heading.

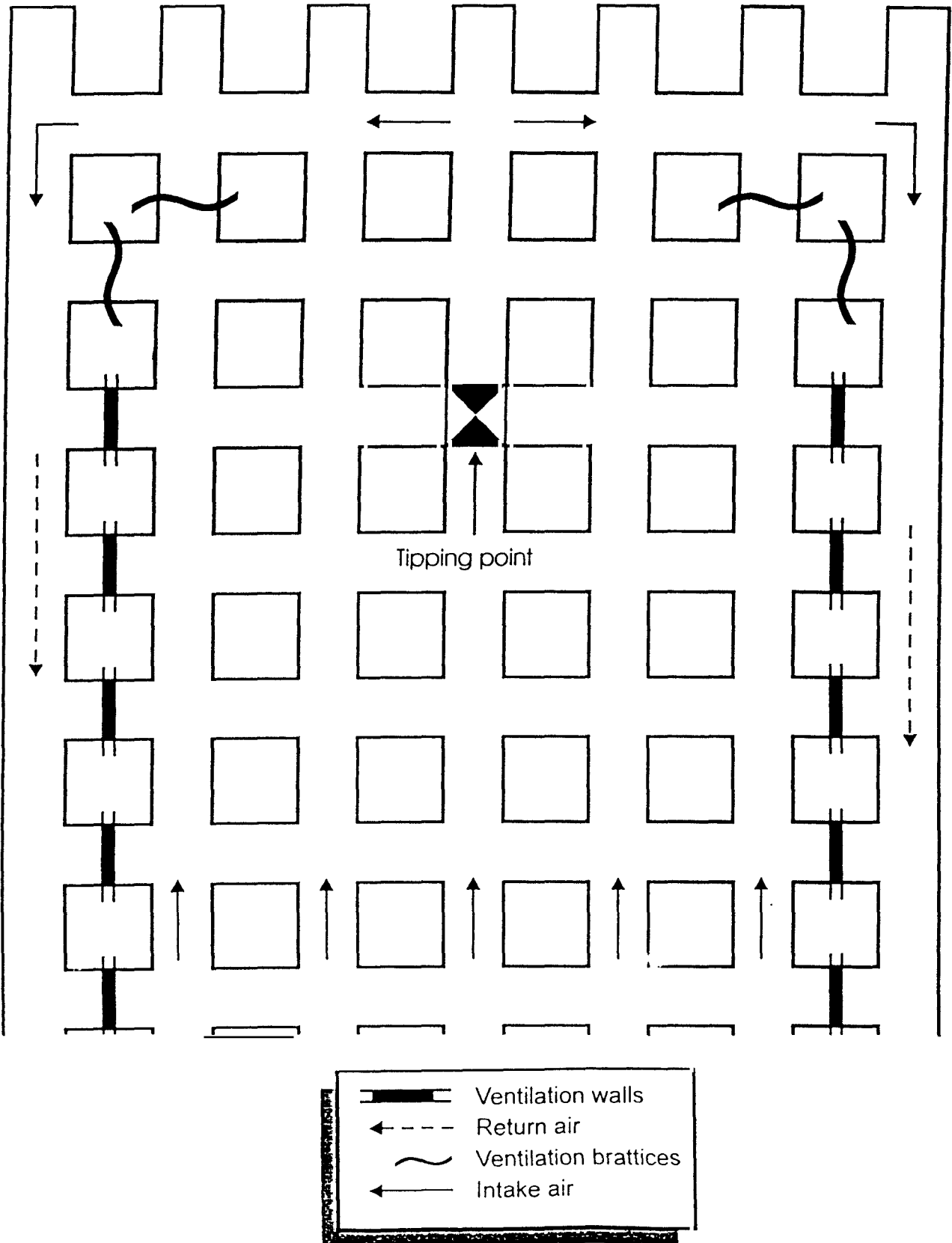

Figure 8 8 Section ventilated by the splitting method

### **(a) Force ventilation with ducting**

This system requires the use of 760 mm  $\varnothing$  axial flow force fans capable of handling between 10 m<sup>3</sup>/s and 14 m<sup>3</sup>/s of air. These fans are usually placed at the last permanent stopping in the intake road. From this point, flexible ducting is used to deliver the air onto the face (Figure 8.9). The size of the ducting ranges from 406 mm  $\varnothing$  to 760 mm  $\varnothing$  and is usually suspended from the roof using roofbolts.

Force ducts are very seldom used as the only ventilation source in the heading. Although the conventional force/exhaust overlap system are not commonly used in the coal mine industry, the force duct is often combined with the on-board scrubber, which on its own is an exhaust system. The scrubber is mainly used for dust scrubbing purposes, but the high volumes pulled through by the scrubber fan, naturally influence the airflow patterns. If needed these systems can also be combined with an exhaust duct to assist with the dust control in ultra high seams. Figure 8.10 shows a typical layout of a heading with a force duct, an exhaust duct and an on-board scrubber with an indication of the expected airflow patterns<sup>7</sup>.

### **(b) Scoop brattices<sup>a</sup>**

Not as commonly used in mechanical miner headings, but a very applicable method of ventilating non-coal winning headings, where the 0,2 m<sup>3</sup>/s/m<sup>2</sup> do not apply and where the seam heights permit the practical installations of these brattices. These can be used to comply with the guidelines on mechanical miners, which states that all non-coal winning headings should be ventilated positively on a continuous basis. They should be installed in the upstream position of the heading relative to the direction of the airflow in the LTR. The tail of the scoop should reach into the LTR to ensure maximum air delivery and air penetration. Figure 8.11 explains the detail on the installation of these scoop brattices.



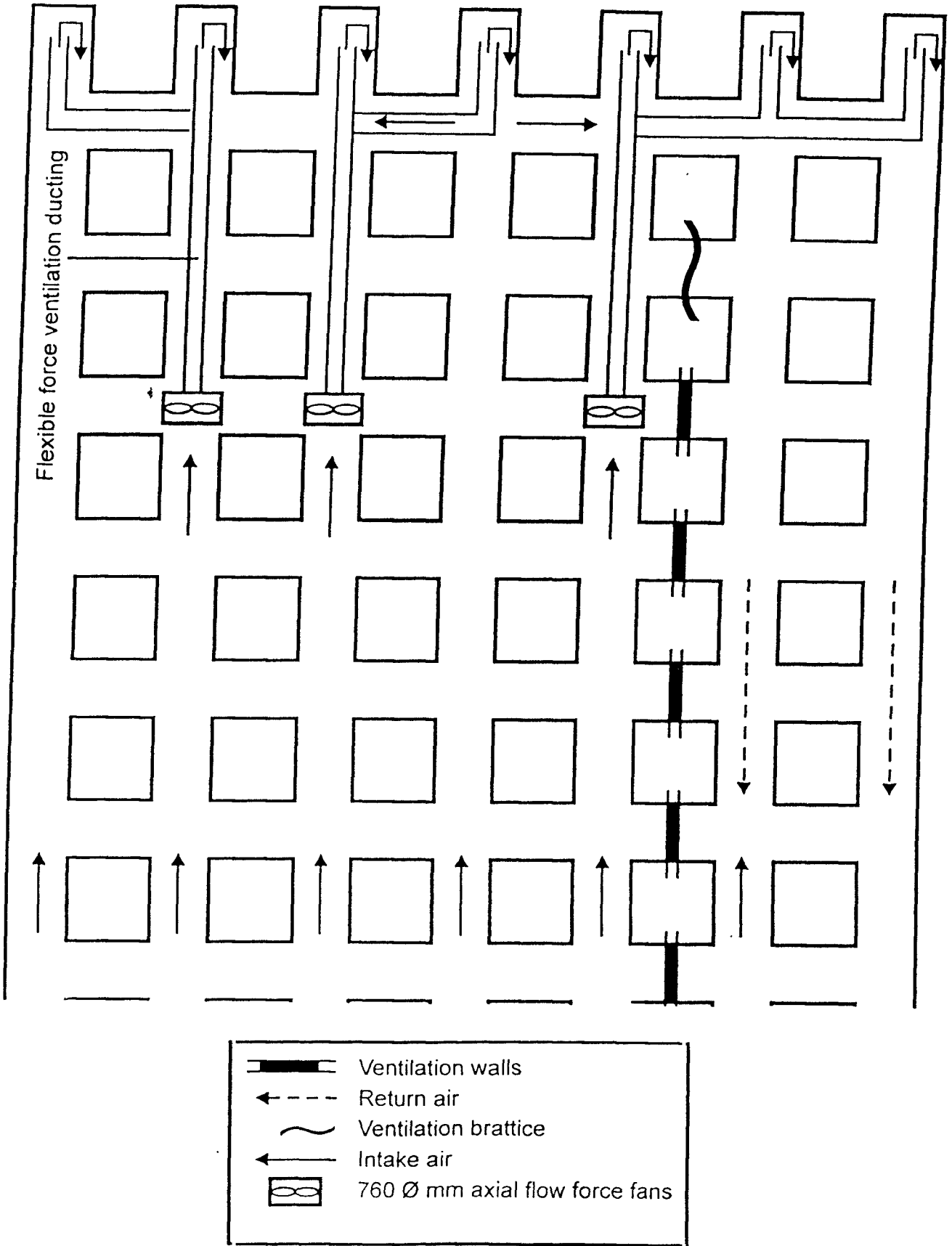

Figure 8 9 Headings ventilated by means of force ventilation with ducting

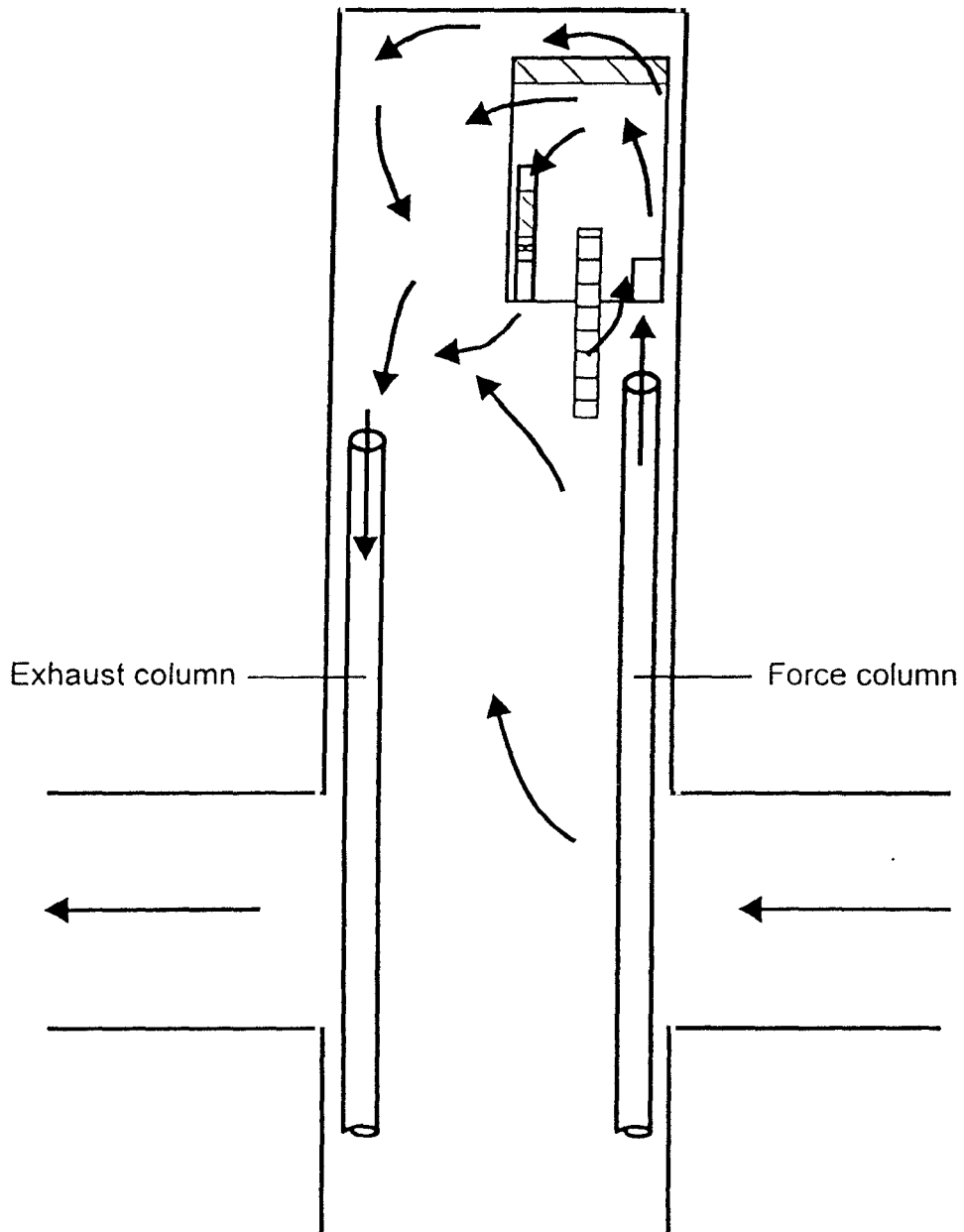

Figure 8.10 Airflow patterns with a force duct, on-board scrubber and exhaust column in use

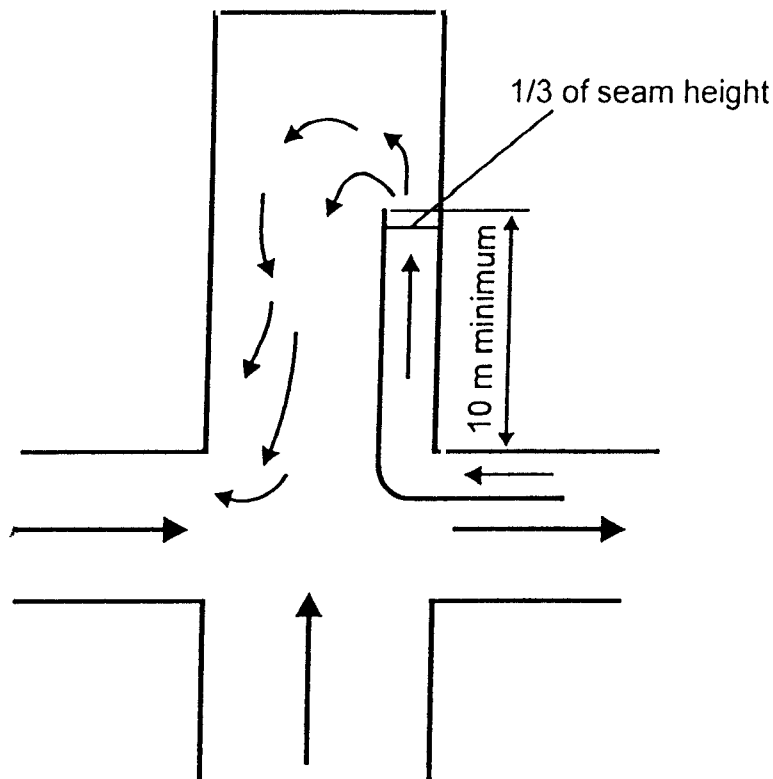

Figure 8.11 Installation of a scoop brattice inside a heading

(iv) Trailing exhaust system

The trailing exhaust is an exhaust duct which has been connected to the outlet of the on-board scrubber. The dust is then extended to a position into the LTR so that the air flowing out of the dust complements the flow of air in the LTR. The ducts which are used are usually PVC re-inforced spiral ducting of 570 mm  $\phi$  or 760 mm  $\phi$ , the positioning of the ducting has practical difficulties and can either be installed against the roof or dragged along on the floor, and is an issue which is solved by the individual mines. This system can be used with or without force ventilation. Figure 8.12 shows a typical layout of a Continuous Miner (CM) heading with a trailing exhaust without any force ventilation.

(v) Directional sprayfan system<sup>9</sup>

The sprayfan system consists of a number of directional sprays which are placed on strategic positions on the boom of a CM. To date, this system has not been tested and/or proven on a roadheader, but is very successful on a CM.

The number of watersprays which are used, differ from CM to CM and each mine tends to change the configurations of the sprays to suit their specific circumstances.

The nozzles are mounted on manifolds behind the cutter head and along the side of the CM. The objective of these spray nozzles is to provide air movement on the face for methane dilution and dust control purposes, as well as for pick lubrication. Figure 8.13 shows the different positions for the spray nozzles.

The ability of these nozzles to move air in a required direction was accomplished by careful selection of the mounting positions of the spray manifolds and angles of the individual sprays on these manifolds. Each nozzle acts like a miniature fan and in combination they direct the air down one side of the CM and over and under the cutting drum. Figure 8.14 shows a typical airflow pattern around the cutting drum with the

directional sprays in use. Areas which require special interest for air movement, are under the cutting drum, as methane tends to build-up in these areas due to the lack of fresh air supply. Too many spray nozzles in these areas, however, cause a water problem for the production people.

The optimum operating pressure is 1 Mpa with pressures down to 750 kPa proving adequate in less gassy seams. Booster pumps may be required where supply water pressure or flow rates prove inadequate. Paper filtration must be provided to prevent nozzle blockage and the system requires regular inspection and maintenance.

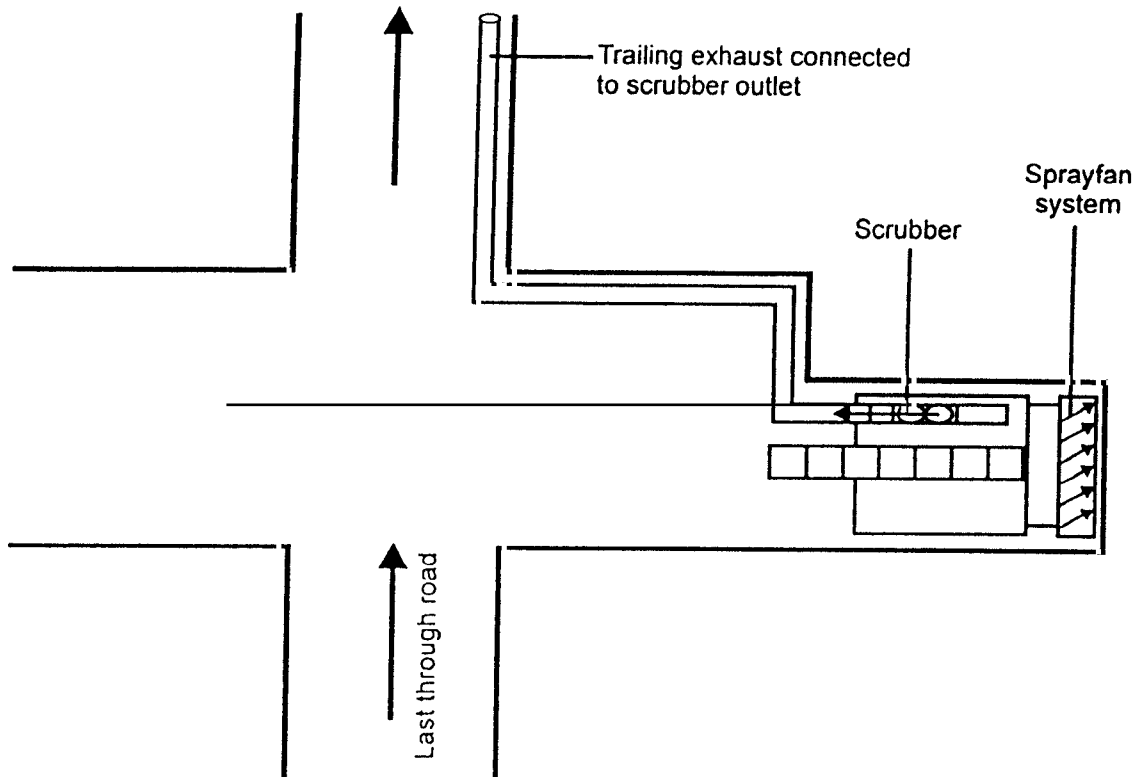

Figure 8.12 Sketch showing a trailing exhaust connected to a scrubber outlet

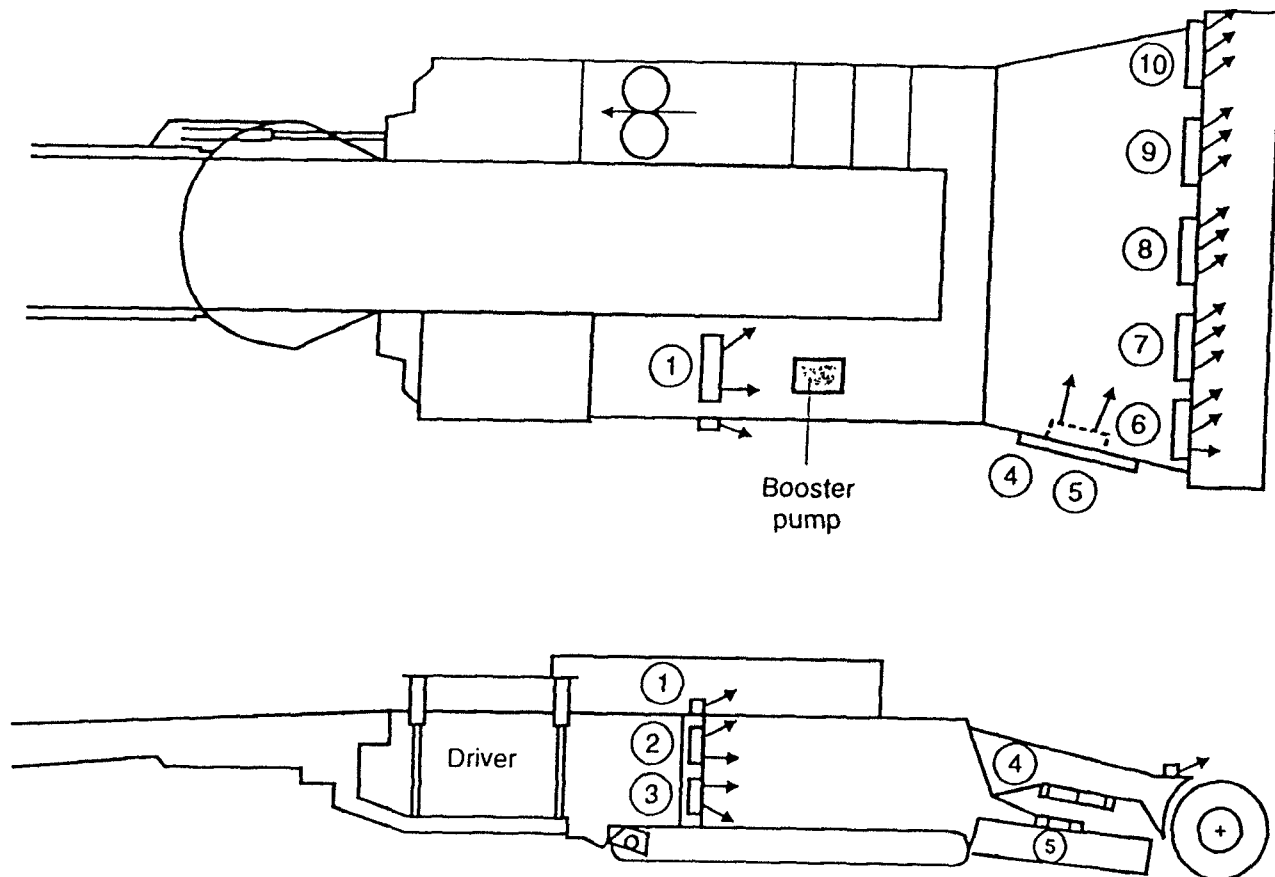

Figure 8.13 Sketch showing the different positions for the spray nozzles

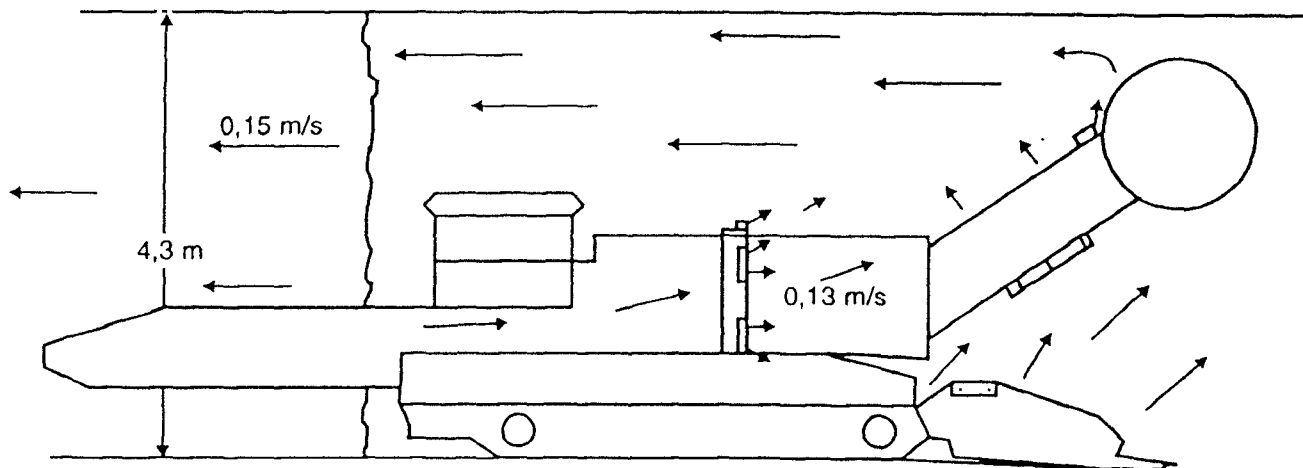

Figure 8.14 Typical airflow patterns around the cutting drum with the directional sprays in use

Research has shown the directional sprayfan system can increase the quantities of fresh air movement to the face by as much as 300 %.

The sprayfan system is recommended for use in conjunction with all the relevant auxiliary ventilation systems which are used to ventilate the mechanical miner heading. The system ensures a constant flow of air on the face and the dust is moved away from the driver towards the scrubber and/or exhaust intake.

### **8.5.2 Some Basic Recommendations to be considered when installing various Ventilation Systems**

#### **(a) Force ventilation with ducting**

The following recommendations can be made when using this system:

- The ducting should be installed on the upstream side of the heading, not opposing the air flowing from the outlet of the scrubber system.
- The distance of the outlet of the duct should not be closer than 10 m to 15 m from the face. If the outlet is too close to the face, the force of the air creates a dust problem, as well as interfering with the working of the sprayfan system.
- The air quantity which is delivered to the face should be in excess of 0,2 m<sup>3</sup>/s/m<sup>2</sup> of cross-sectional face area.
- leakage should be kept under control to ensure the required air quantity on the face.

#### **(b) Exhaust ducting and/or on-board scrubbers**

Some mines prefer to use exhaust systems in the headings mainly to address the dust generated. Aspects which should be kept in mind when using exhaust systems, whether an on-board scrubber system or a conventional exhaust dust are:

##### *(i) On-board scrubbers:*

- The maximum distance that a mechanical miner can operate away from the LTR when using a large wet scrubber as the only means of ventilation movement, is 20 m for medium to high coal seams. With regard to the low seams, it is recommended the scrubber quantity be limited to the minimum required for that particular heading face area and that the distance away from the LTR be limited to not more than the machine length ( $\pm$  10 m)
- The air quantity which should be delivered by the scrubber is determined by the factor 0,4 m<sup>3</sup>s/m<sup>2</sup> of cross-sectional face area.
- Efficiency of the scrubber inlet can be problematic. Care should be taken that the airflow direction on the face of the heading is always in the direction of the scrubber inlet to maximise the capture capabilities of the scrubber.
- It is advised that the on-board scrubber be used together with a sprayfan system, or any other air moving device on the cutting drum. This is to assist with creating

positive air movement on the face.

- It is recommended that the outlet of the scrubber be directed towards the roof, as will assist in creating turbulence levels against the roof at the back of the machine.
- The scrubber should not be allowed to recirculate more than 50 % of its own air inside the heading. This is normally controlled by limiting the distance of the scrubber from the LTR.

(ii) *Exhaust ducting*

The airflow inside the heading behaves in the same manner with the exhaust ducting as with the on-board scrubbers, but with the difference that the positioning of the duct creates problems for effective dust control. It is often necessary to assist the exhaust duct with some type of air mover on the machine, such as the sprayfan system. This ensures that the dust is moved towards the exhaust intake, creating positive airflow on the face.

- The inlet of the exhaust duct should not be further than 10 m from the face to ensure sufficient air movement on the face and in the heading, and to enhance the capturing capabilities of the duct inlet.
- The duct should be installed on the downstream side of the heading against the roof, as this ensures a positive flow of fresh air over the driver.
- The exhaust air quantity should be more than the required  $0,4 \text{ m}^3/\text{s}/\text{m}^2$  of cross-sectional face area.
- In the high seams, turbulence levels against the roof are low and additional air moving systems are needed to create the turbulence needed against the roof for methane dilution purposes.

(iii) *Trailing exhaust connected to the scrubber outlet*

This system is the same as the normal exhaust duct which was discussed previously. The one advantage is that the inlet to the scrubber is kept close to the face at all times.

- The same recommendations apply to this system as was discussed for the scrubber system
- The outlet of the duct should reach into the LTR, as close as possible to the main return airway.
- Low turbulence levels against the roof, will also manifest when this system is used in high seams. The solution for this would be to use additional force ventilation in the entrance part of the heading. To big a fan might in turn create a dust problem. It is, therefore, important to maintain a balance between the force and exhaust quantities inside the heading.

### 8.5.3 Airjet fans <sup>5</sup>

The use of airjet fans to ventilate bord and pillar headings, are becoming a popular system in the coal mining industry. This is because of the ease of use and the good mixing characteristics obtained from the technique.

These fans are placed at specific positions in the LTR forcing air into the headings, the

energy of the air leaving the fan nozzle is causing additional fresh air to be entrained into the heading, which results in air quantities in excess of twice the fan quantity being delivered into the face area.

These fans create basically two types of airflow patterns. There is a normal "U" shape pattern and the "Figure of eight" flow pattern. These patterns are a function of the fan inside the LTR. Figures 8.15 and 8.16 illustrate these two types of airflow patterns. The "X" on the sketches indicate the direction the fan nozzle is pointed to achieve these flow patterns.

Specific rules with regard to the correct usage of these fans should be adhered to. These include the following:

- The fans should be placed in the upstream position of the heading with regard to the LTR airflow direction.
- This position should be on the opposite side of the on-board scrubber (if applicable).
- It should be placed in a position where it would not recirculate.
- The position of operation inside the LTR can be either on the floor or against the roof.
- When used inside a mechanical miner heading, it should be used in conjunction with an on-board scrubber and/or additional air moving devices such as the sprayfan system.
- It is not advisable to use a jet fan within the first 10 m of heading development, because of the dust problems it may create due to the high air velocities generated.
- The fan should be placed in such a position that the "U" shape airflow pattern is created inside the heading to compliment the airflow from the on-board scrubber.



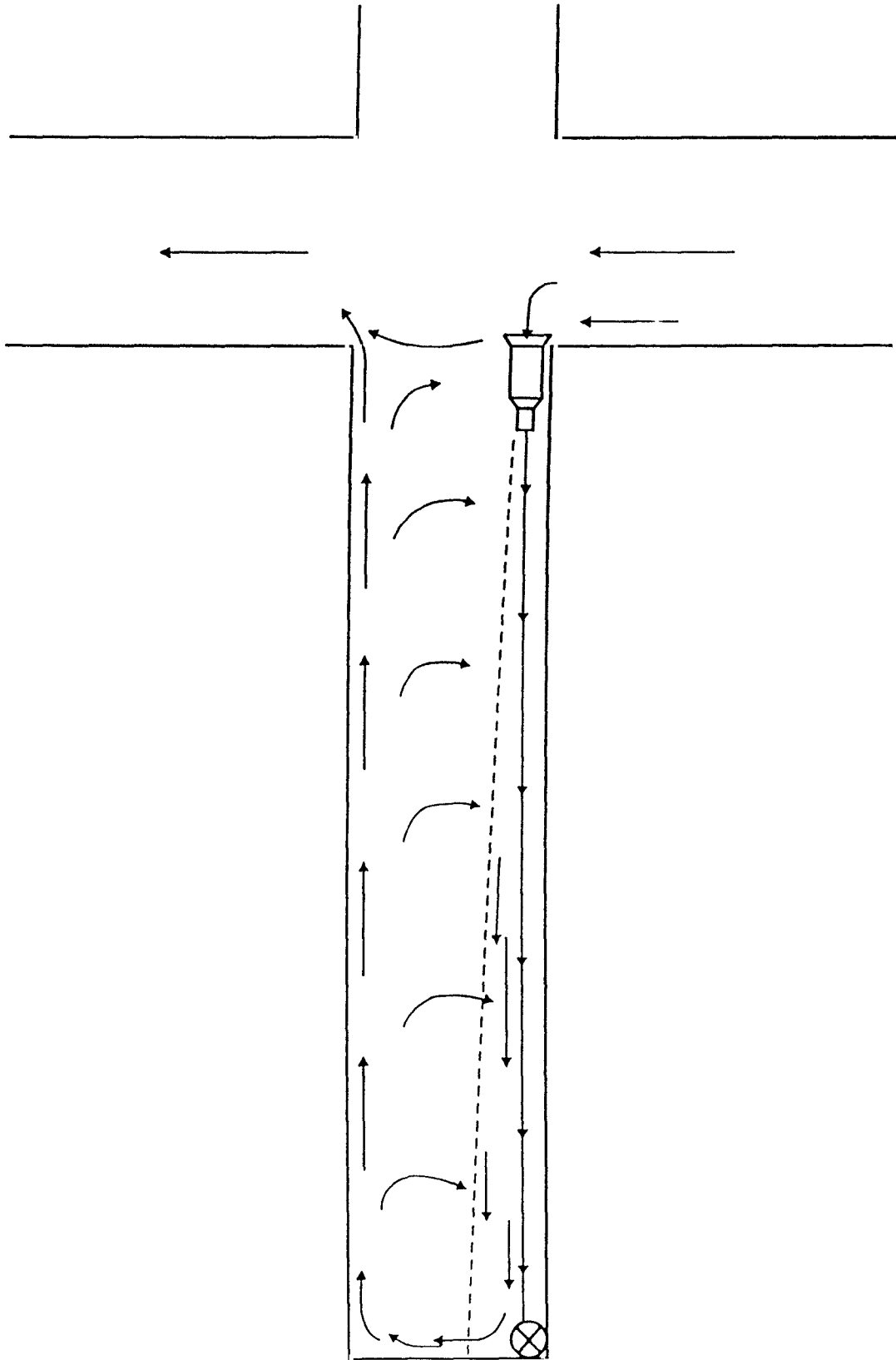

Figure 8 15 Sketch showing the normal "U" shape airflow pattern

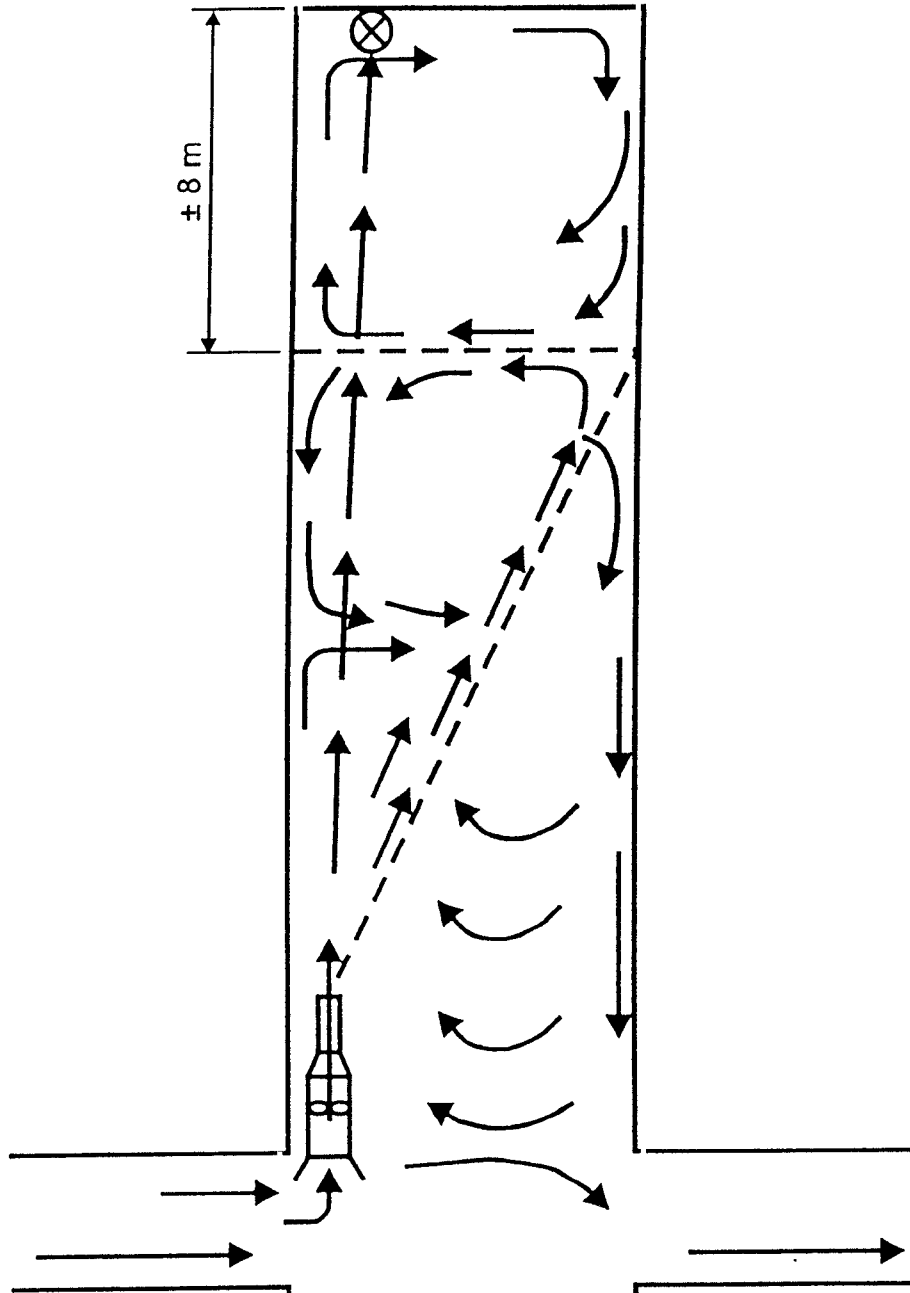

Figure 8.16 Sketch showing the "figure of eight" airflow pattern

#### 8.5.4 Ventilation of Bord and Pillar Split Development

In the past various different methods have been used by the mines to develop splits and, as a result, different ways of ventilating these splits have been adopted.

Ventilating these splits has always proved to be a problem and, as a result of this, research has been conducted into this area and the general conclusion reached is that split development should be ventilated using ventilation ducting. In some instances where the pillar sizes allow it, the on-board scrubber system could prove to be sufficient to ventilate the split.

Because of the problems and difficulties associated with the use of ventilation ducting, the

mining methods and sequences should be adopted to limit the number of roads which are to be ventilated in this manner. One proven method of accomplishing this, is to mine each through road of the section by starting on one side of the panel through to the next side of the panel. By doing this it is only necessary to ventilate the first split by means of the force duct. After this first holing has been established, the LTR is diverted and the remainder of the splits which need to be mined are treated as headings with a LTR flowing past. Other auxiliary systems such as jet fans can now be used to ventilate these headings.

Before the best alternatives are discussed, it should be noted that the direction of the LTR is very important with regard to the position of the scrubber on the machine. As explained earlier under heading ventilation, the LTR should always run from left to right past the heading in the case of left handed machines and from right to left in the case of right handed machines. These rules also apply with split ventilation if this particular mining method is adapted. The reason being that the force ventilation systems should always be installed on the upstream side of the heading in the LTR. This should be self explanatory as the alternatives are discussed.

### **(a) Left handed machines (scrubber on the right)**

#### *(i) The last through road is running from left to right*

There are basically two mining methods which can be used. The development can either be conducted from left to right through the panel, or from right to left through the panel. There are differences in the behaviour of the airflow when the two options are used. As the details are explained the best alternative will be mentioned with regard to airflow and the control of hazardous substances.

#### *(ii) Mining from right to left (against the flow of air)*

For ease of explanation, a 5 road section will be used as an example. The roads are numbered from 1 on the left, through to 5 on the right, and will be shown on all the sketches. Two development stages will be discussed, the first split and then the second stage of the development where the split is treated as a heading. The ventilation system for the second stage will be limited to a jet fan for explanation purposes. Figure 8.17 (a) shows a section layout where the ventilation is flowing from left to right in the LTR. The first split is mined from road 5 in the direction of road 4 and includes the correct installation position of the force ventilation.

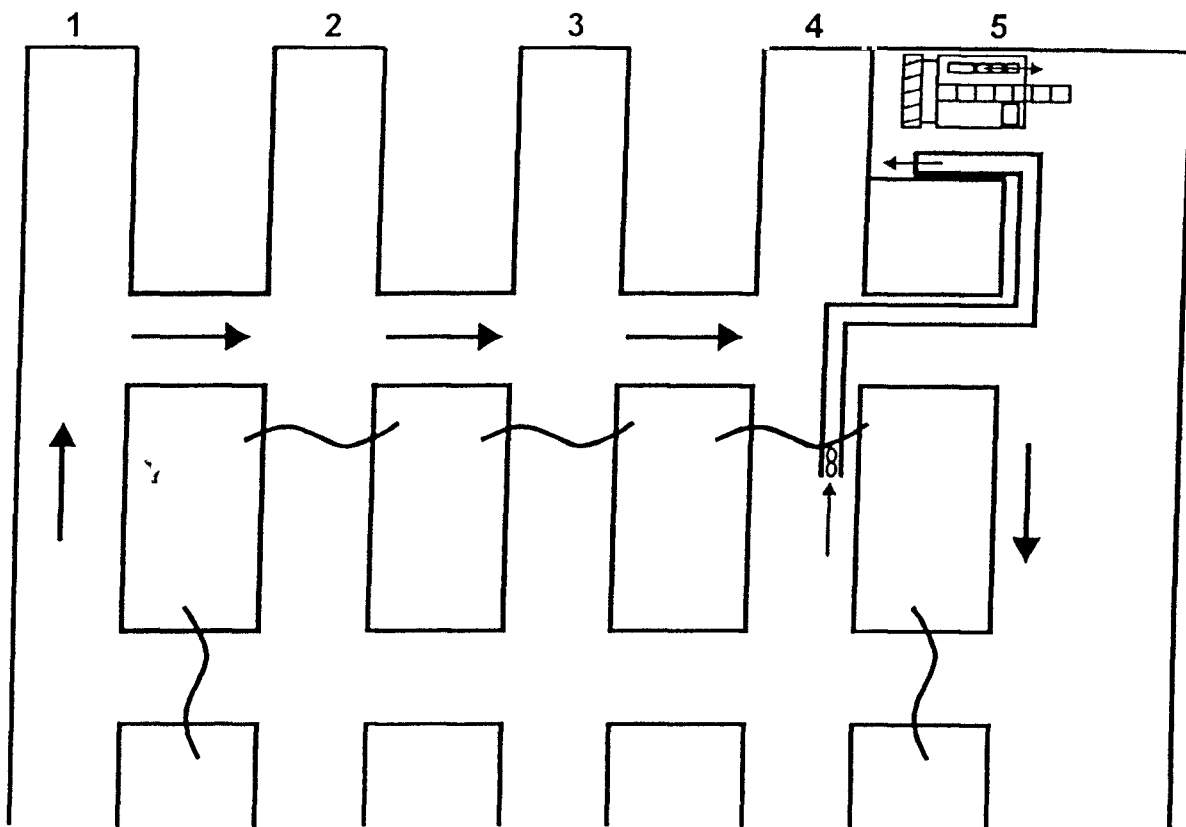

Figure 8.17 (a) Split development from road 5 to road 4

The initial holing is made into road 4, which means the dust will be blown over the driver and past the scrubber into road 5. Every consecutive holing through to road 1 will experience the same situation. This will, however, be of short duration and if the holing sequence is controlled, most of the dust should be directed away from the driver towards the scrubber inlet. To control this, the first initial cut through should be made on the left hand side of the face continuing through to the right hand side of the face. The ventilation will be forcing the dust away from the driver to the right of the machine.

Some mines also prefer to start the cut through sequence in road number 4 instead of road number 5. Figure 8.17 (b) shows this layout where the first split is mined from road 4 in the direction of road 5. The sketch also shows the installation position of the force ventilation.

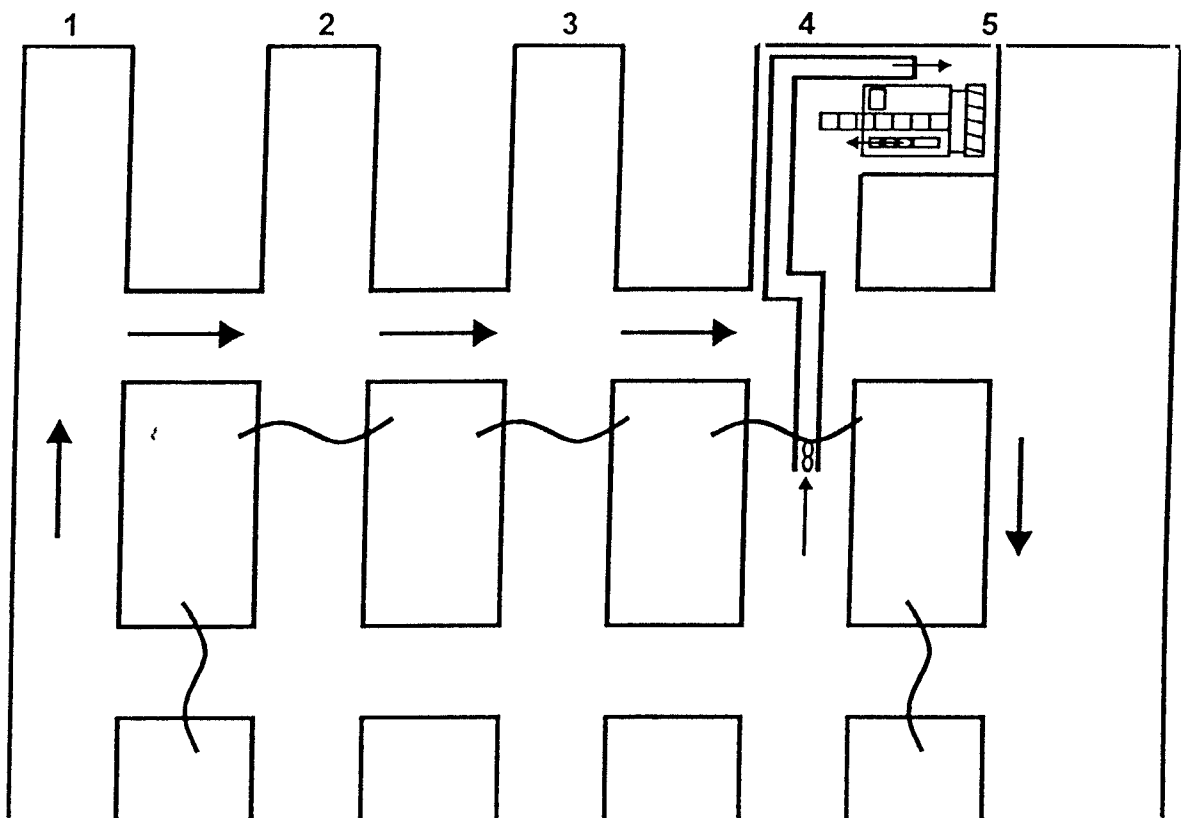

Figure 8.17 (b) Split development from road 4 to road 5

The difference in this case is that the first holing will be with the flow of air. The dust will be blown into road 5, away from the driver, with the remaining holings once again be against the flow of air as explained in the previous scenario.

Figure 8.17 (c) shows the second stage of this development after the LTR has been diverted. The sketch indicates the correct operating position for the jet fan with regard to the scrubber position and the flow of air in the LTR.

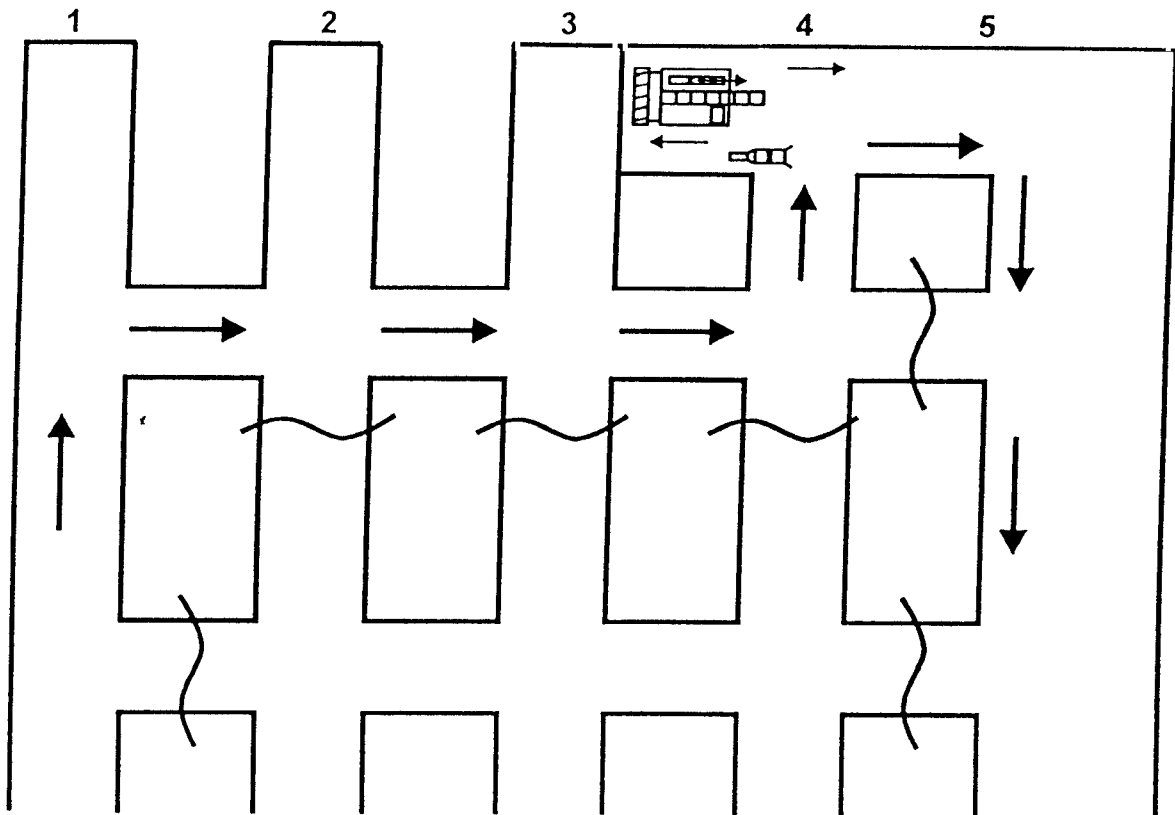

Figure 8.17 (c) Sketch shows the second stage of the development with a jet fan

The jet fan should be placed on the left hand side of the heading in the LTR (upstream), with the scrubber situated on the right hand side of the machine.

*(iii) Mining from left to right (with the flow of air)*

Depending on the infrastructure in the section, as well as other factors, some mines might prefer to use this alternative. Mining would then commence in either road 1 or 2, and continue through to road 5. The following sketches will illustrate this. The air is still flowing from left to right in the LTR.

Figure 8.18 (a) shows the first stage when the first split is being mined from road 1 in the direction of road 2. The illustration position of the face ventilation system is indicated. When the holing is made, the dust will flow away from the driver into road 2.

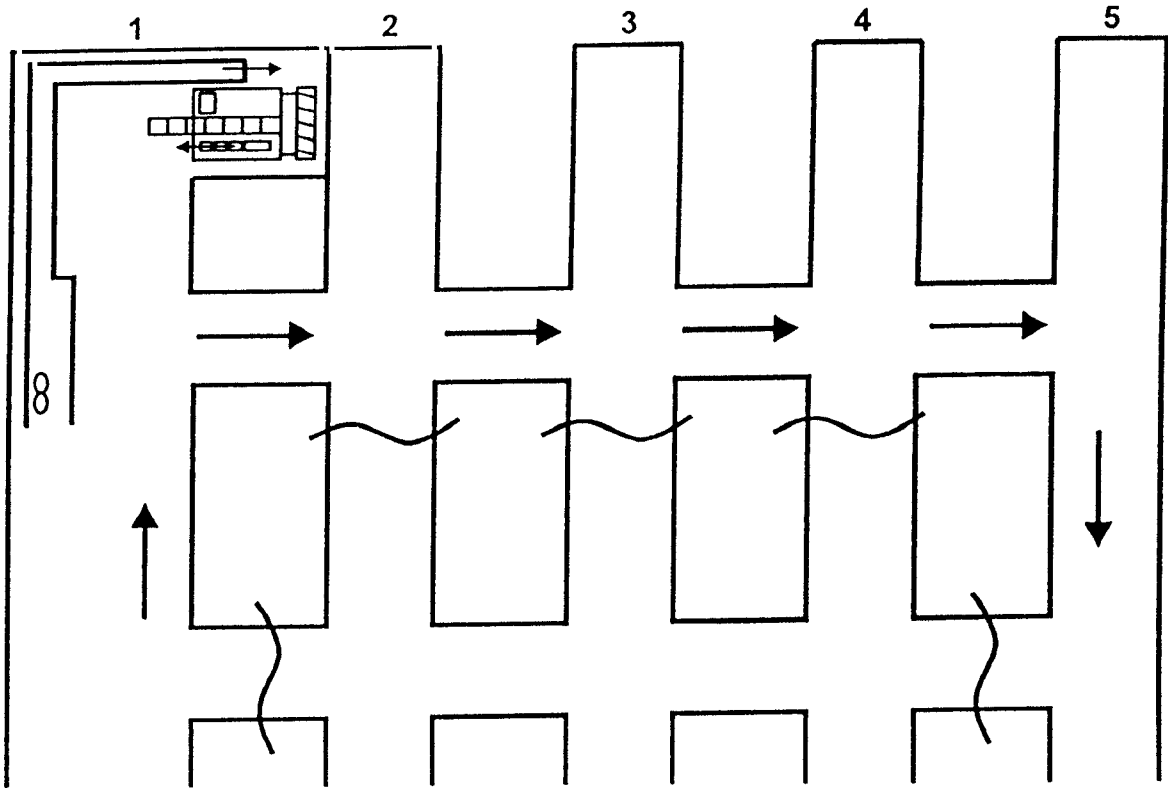

Figure 8.18 (a) Split development from road 1 to road 2

As the mining sequence is carried out each holing will experience the same conditions. This alternative is recommended for left handed machines using on-board scrubbers and auxiliary force ventilation

If so preferred, the first holing can be made from road 2 through to road 1 as is shown in Figure 8.18 (b). The sketch also shows the installation position of the force ventilation.

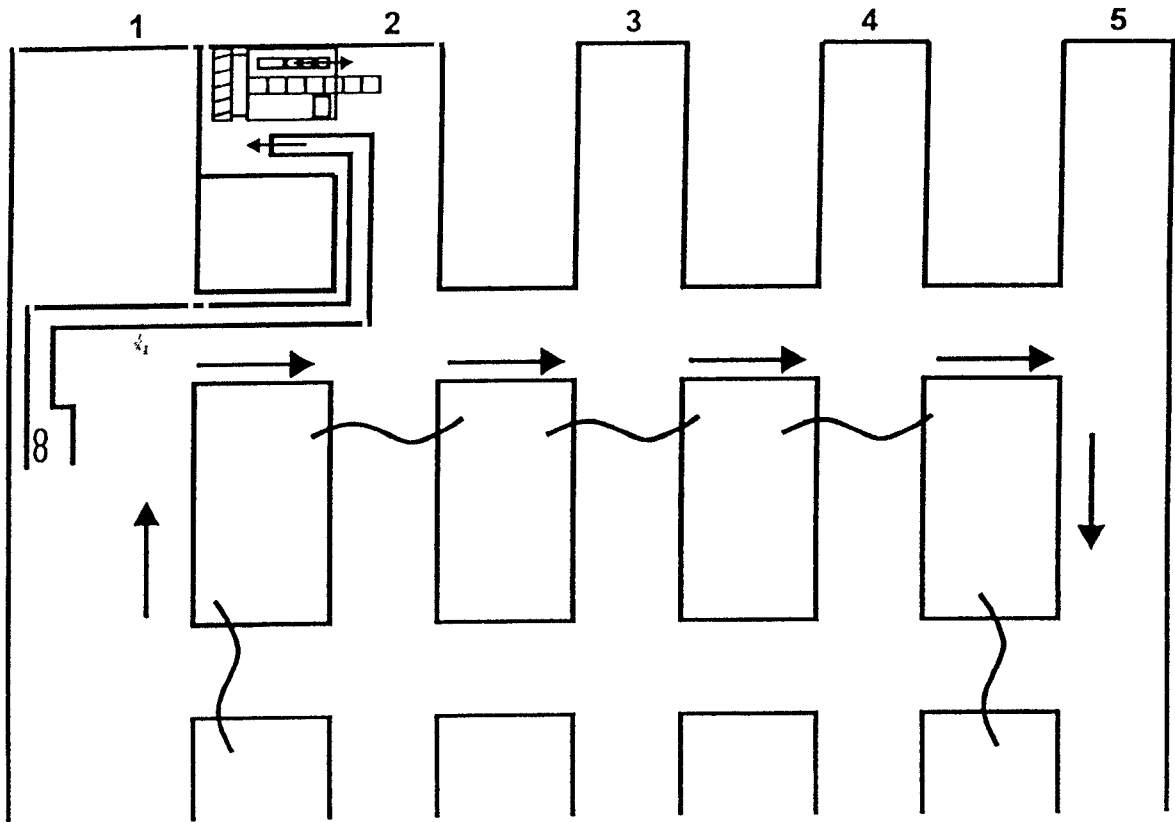

Figure 8.18 (b) Split development from road 2 to road 1

The only difference now would be that the first holing will be against the flow of air which will mean dust over the driver for a short duration of time.

Figure 8.18 (c) shows the second stage of the development when roads 2 and 3 are connected with particular reference to the positions of the jet fan.



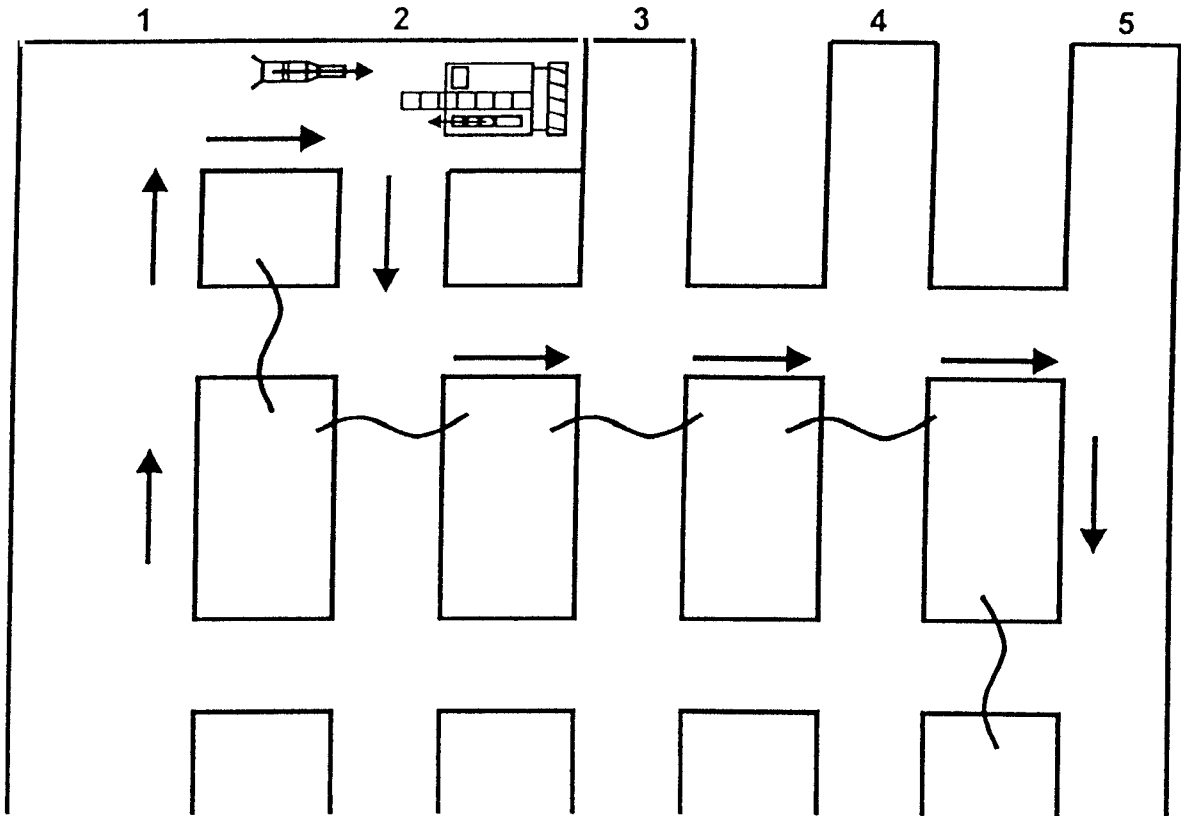

Figure 8.18 (c) Sketch shows the second stage of the development with a jet fan

As shown on the sketch, the jet fan should be installed on the left side of the heading, extending into the LTR. It should be in such a way that the air flowing from road 1 is flowing directly over the jet fan to prevent air re-circulation.

**(b) Right handed machines (scrubber on the left)**

*(i) The last through road is running from right to left*

For right handed machines, the situation is just reversed and the same problems will be experienced as described before. The holing procedure should be conducted from the right corner of the face to the left, in order for the force ventilation to push most of the dust to the scrubber inlet away from the driver.

Figures 8 19 and 8 20 show examples of the situations where the mining is carried out with, and against the flow of air and the positions of the auxiliary ventilation. The sketches also show the second stage of development when the LTR has been re-directed and the jet fans are in the correct positions and the airflow direction

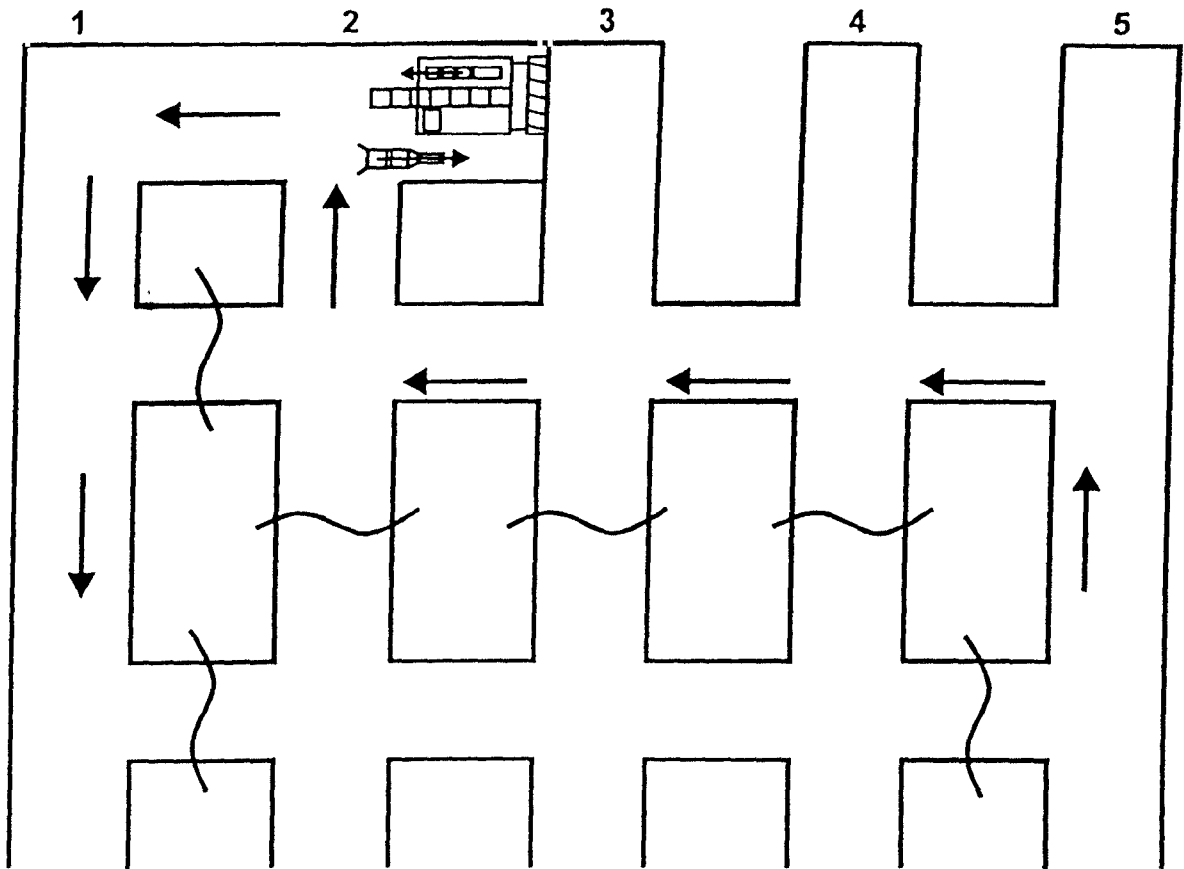

Figure 8.19 Second stage of the development against the flow of air

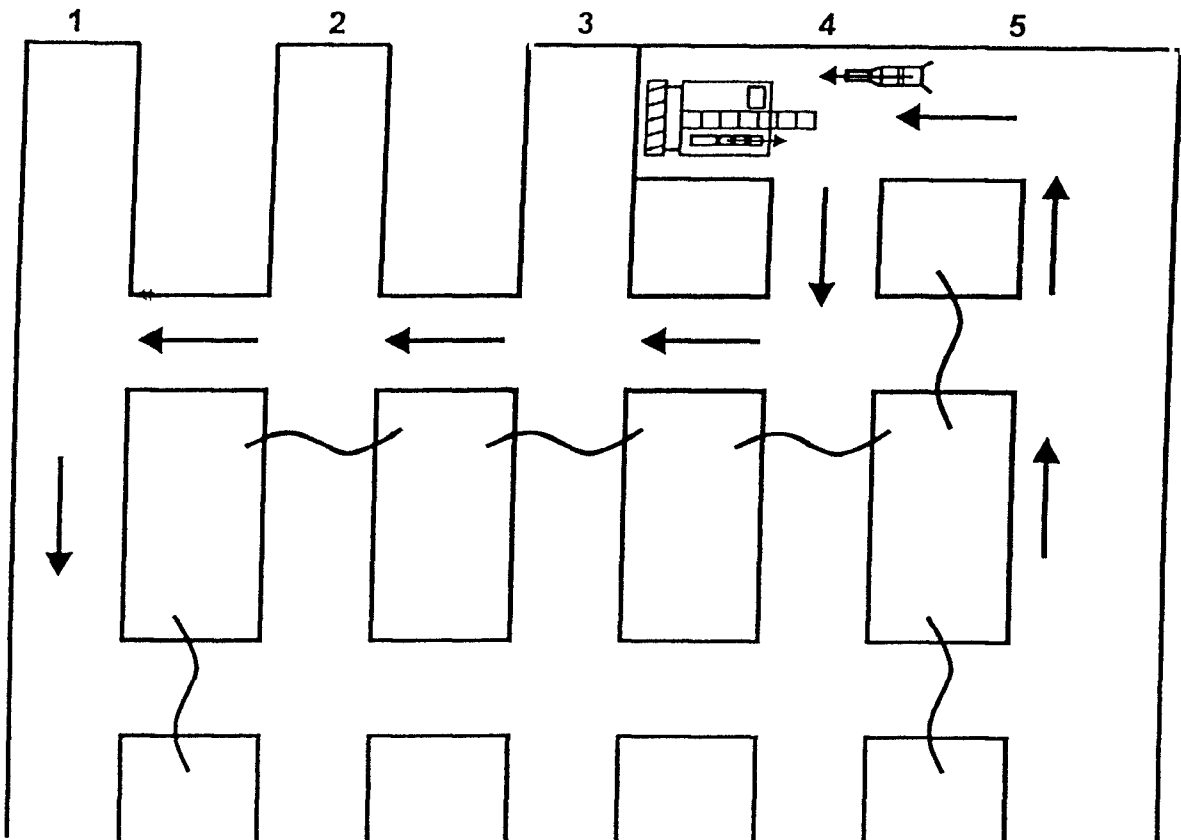

Figure 8.20 Second stage of the development with the flow of air

(ii) *Recommendations for the ventilation of split development*

With all the information supplied and alternatives discussed, the following recommendations are given with regard to the correct mining sequence and airflow conditions.

- With left handed machines, the air should flow from left to right in the LTR and vice versa for right handed machines.
- Where possible, the mining activities should be conducted with the flow of air to keep the dust away from the driver.
- The first split can be ventilated by means of auxiliary fans and ducting or in the event of small pillar sizes, the on-board scrubber would suffice.
- The auxiliary ventilation should always be installed on the upstream side of the heading/split

## 8.6 The Ventilation of Stopping Sections

Various methods of mining coal reserves are being practiced in South African collieries of which *stopping* is one. *Stopping* is the combined name for two mining methods, namely pillar extraction and rib-pillar extraction, of which the latter is not as commonly used anymore.

With regard to the above, ventilation is very important and should be carried out in such a manner that most of the available air is concentrated on the actual position of mining. Section 8.6 will concentrate on the most common methods used to ventilate these operations during the actual extraction process.

### 8.6.1 Pillar Extraction

Individual mines use different sequences in which the pillars are removed, and different *mining methods concerning continuous miners and the ventilation thereof will be shown and discussed.*

#### (a) Various mining and ventilation methods

(i) *The extraction of the pillars starts on one side of the panel and proceeds in a straight line to the other side of the panel with the following line of pillars then extracted in the opposite direction, forming a criss-cross pattern across the section.*

The air is coursed to the cutting position by closing off the other intake airways with ventilation brattices. The air then flows over the machine and the workers into, and through, the goaf towards the return airway, which is called the bleeder road. The walls separating the intake and return airways are kept intact and a 6,0 m rib pillar is left to protect the bleeder road (see Figure 8.21). In the event of the goaf closing up, which would prevent or hinder the airflow, one or two of the walls are removed to rectify the situation.

Using the brattices to direct the air, 90 % of the total volume of air is concentrated on the machine, leaving 10 % of the air leaking through the brattices into the goaf thereby keeping the goaf area under constant pressure. Using this ventilation method, the respirable dust concentrations are kept under control.

(ii) Another method of establishing the bleeder road for a section, where the pillars are extracted in a straight line, is to use the return airway of an adjacent section as the bleeder road. A holing is made through the barrier pillar separating the two panels, in the top corner of the extraction section. The air is then allowed to bleed through this holing into the adjacent return airway (see Figure 8.22).

One of the returns of the section is converted into an intake airway, while the other return airway is used to return the access air not able to flow through the bleeder road. The walls, as well as the pillars, on the return sides are removed as the section retreats. The brattices are again used to direct most of the air to the cutting position, flowing over the machine into the goaf where it splits to the bleeder road and the return airway

(iii) Some mines prefer not to use the bleeder road option. These are usually the mines which may have a spontaneous combustion problem which is enhanced by the flowing of fresh air through the caved area. With the pillars being extracted in a straight line, the

intake air is forced to the position of cutting by means of brattices. The air flows over the driver into the goaf and flows directly in the return airway alongside the goaf line. To assist in supplying fresh air over the driver in order to remove dust, use is made of an axial flow fan with some flexible ducting connected to it (see Figure 8.23). Problems experienced in the past whenever goafing occurred, was the large amounts of dust which was pushed into the section over the driver.

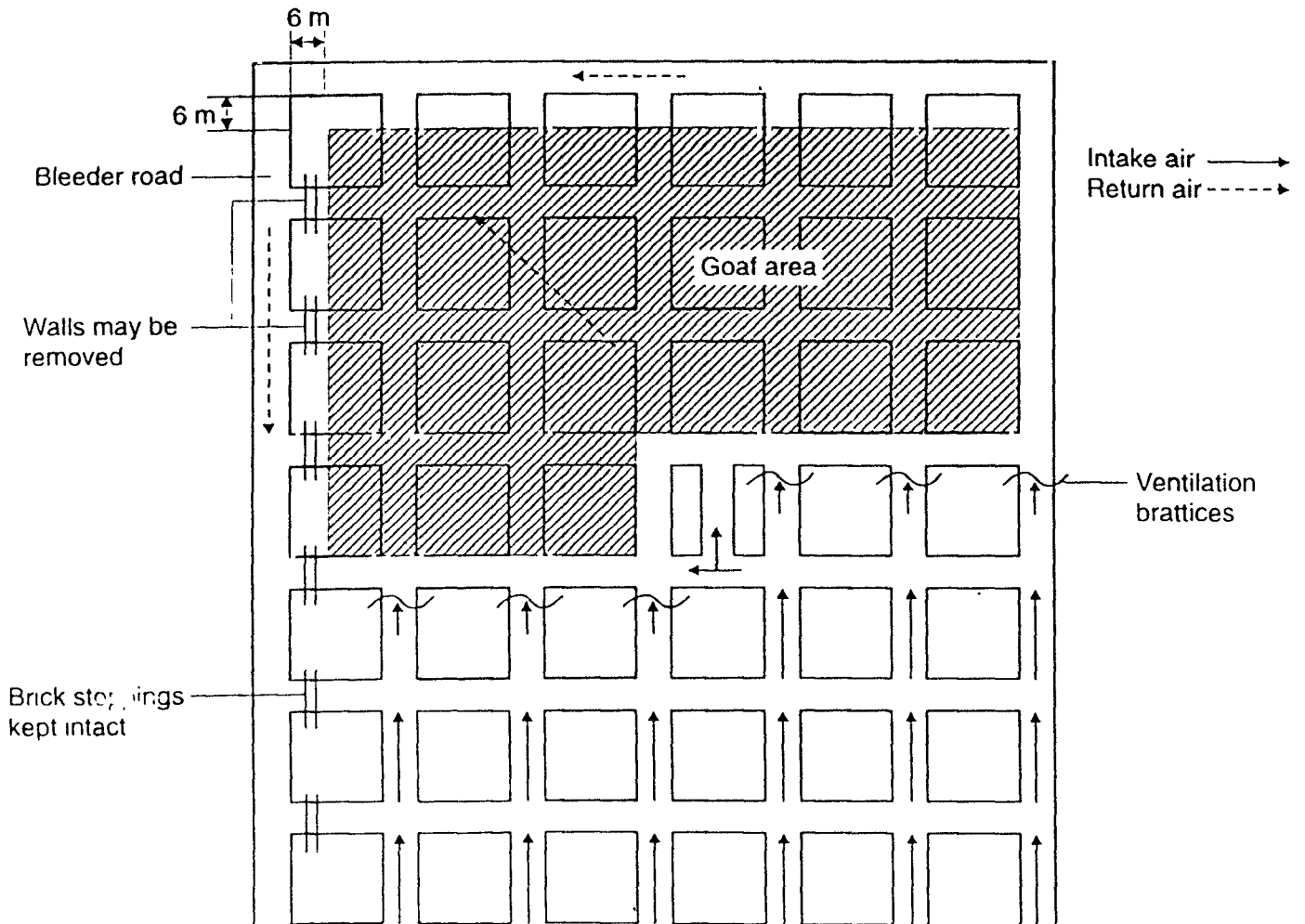

Figure 8 21 Using "over the goaf" ventilation towards a bleeder road at the back of the goaf

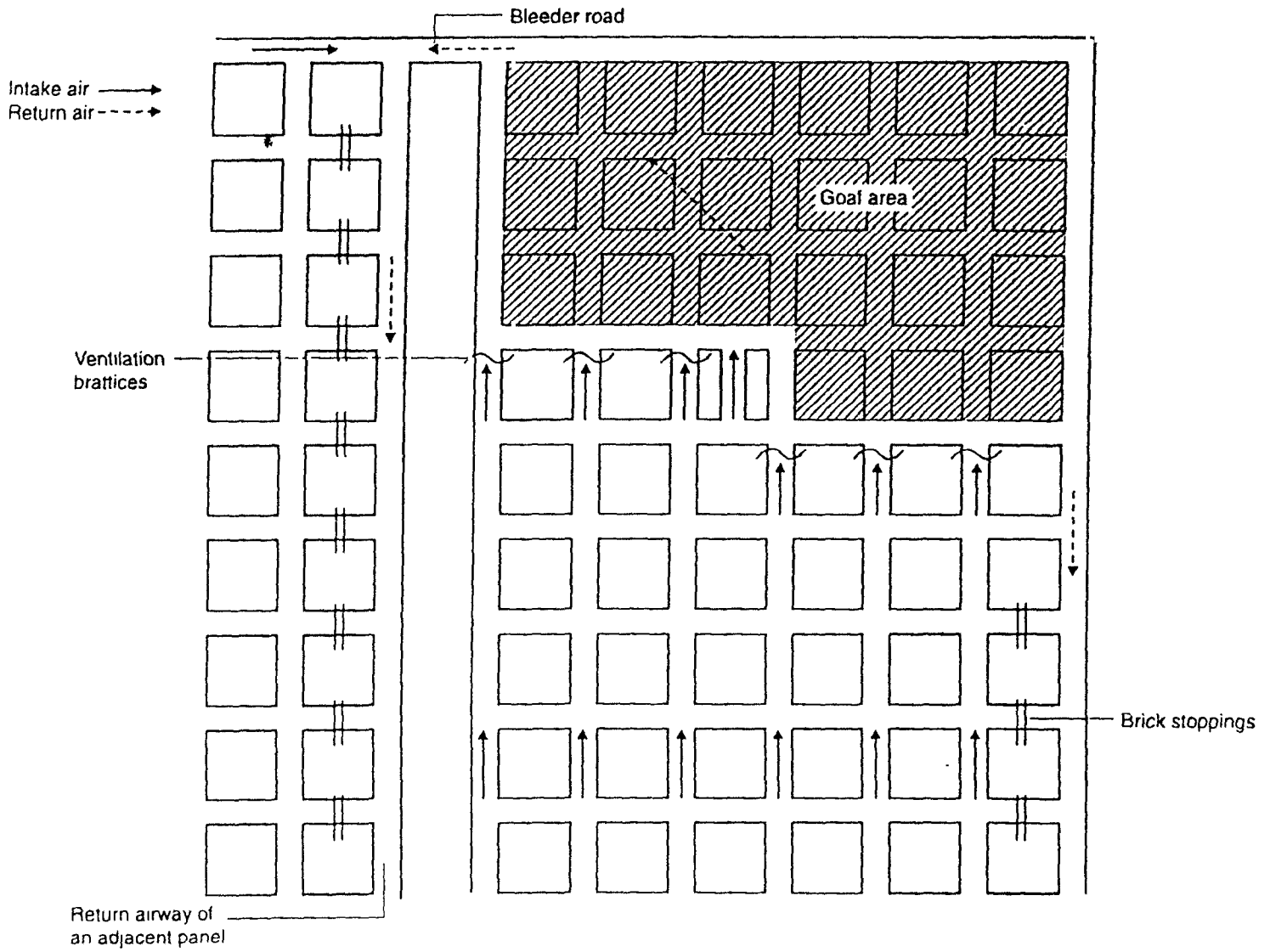

Figure 8 22 Utilizing the return airway of an adjacent section as a bleeder road

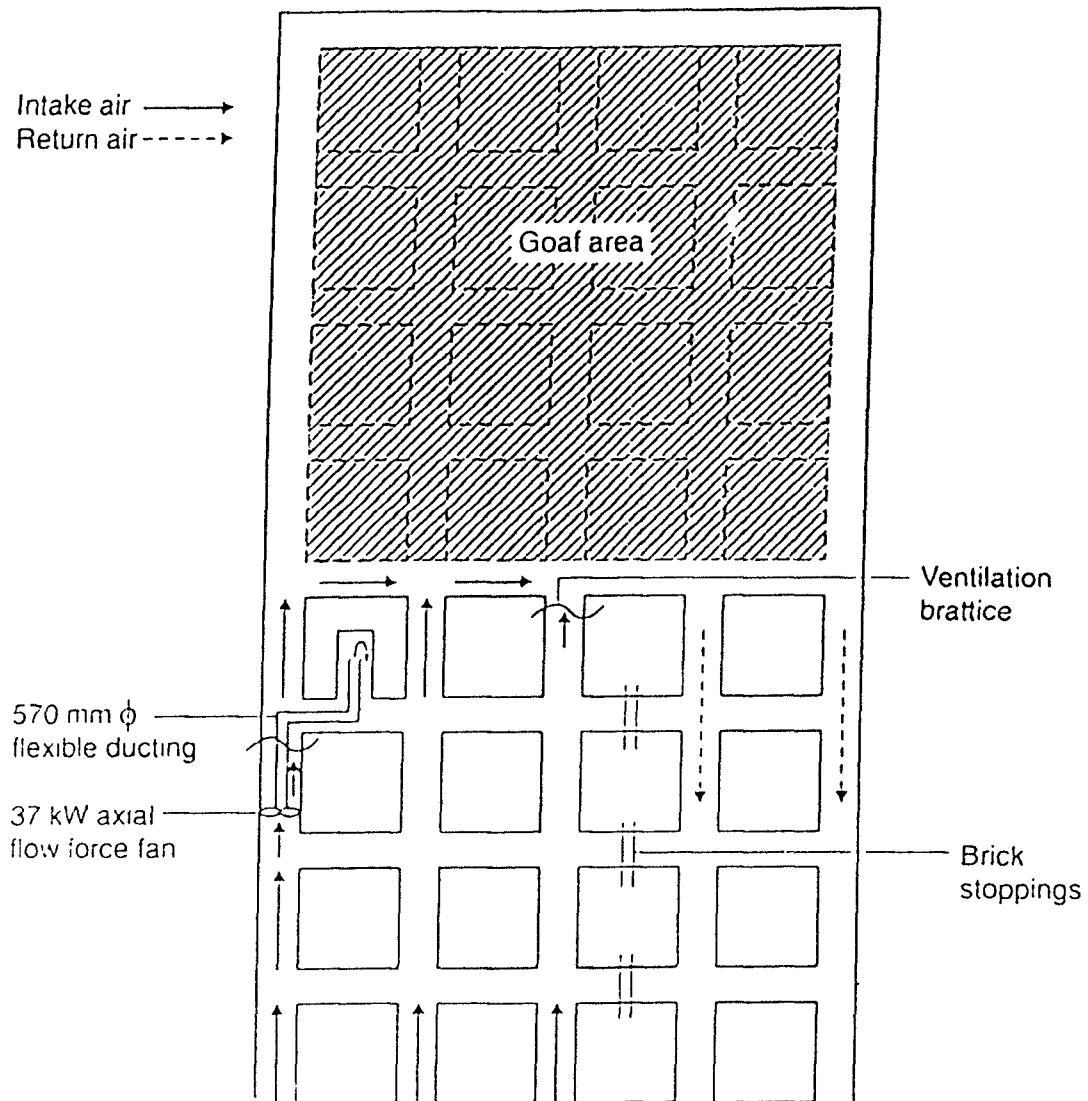

Figure 8.23 No bleeder road system used, with additional force ventilation to supply fresh air over the driver

(iv) Due to geological conditions and structures, it is sometimes necessary to extract the pillars in 45° line, starting at the top of the section on one side, working towards the other side. With this mining layout, the intake airway is established to be at the top of the panel, with the air flowing against the goaf line at the back of the brattices towards the return airway (see Figure 8.24). The air is forced to the point of production by using the ventilation

brattices. The brick stoppings and the pillars on the return side are removed as the panel retreats.

In the event of problems with dust or gas from the goaf area, use can be made of the return airways of an adjacent section (see Figure 8.25). While this method removes the dust and gases from the working area, but the goaf area is still not ventilated and in certain cases, use is then made of auxiliary fans and ducting to ventilate the area around the workers.

### **8.6.2 Rib-pillar extraction**

This mining method is not used very much anymore and the number of mines which might still be using it, are limited. However, it is still an important part of stooping and therefore the possible ways of ventilating this type of mining method still needs to be illustrated.

(i) The development of these panels are vastly different from the normal pillar extraction. The pillars and ribs which are to be extracted, are created in a certain fashion, which is dictated by the geological and strata conditions. The development usually consists of primary and secondary developments from where the tertiary and fender developments are carried out.

During the extraction process, two systems are used simultaneously to ventilate the area. The return road is used as a return road from the goaf area, and the air is prevented from being forced over the goaf area by leaving a protecting pillar, or keeping the ventilation walls intact. The air enters the section via the intake roads and is coursed to the working area by means of the ventilation walls. The air flows through the LTR through the production area directly into the return airway.

In addition, a 37 kW axial flow force fan is used with 570 mm  $\varnothing$  flexible to ventilate the goaf area in the immediate working zone (see Figure 8.26). The fan blows air into the goaf at various positions, reducing the danger of gas near the workers and the machine.



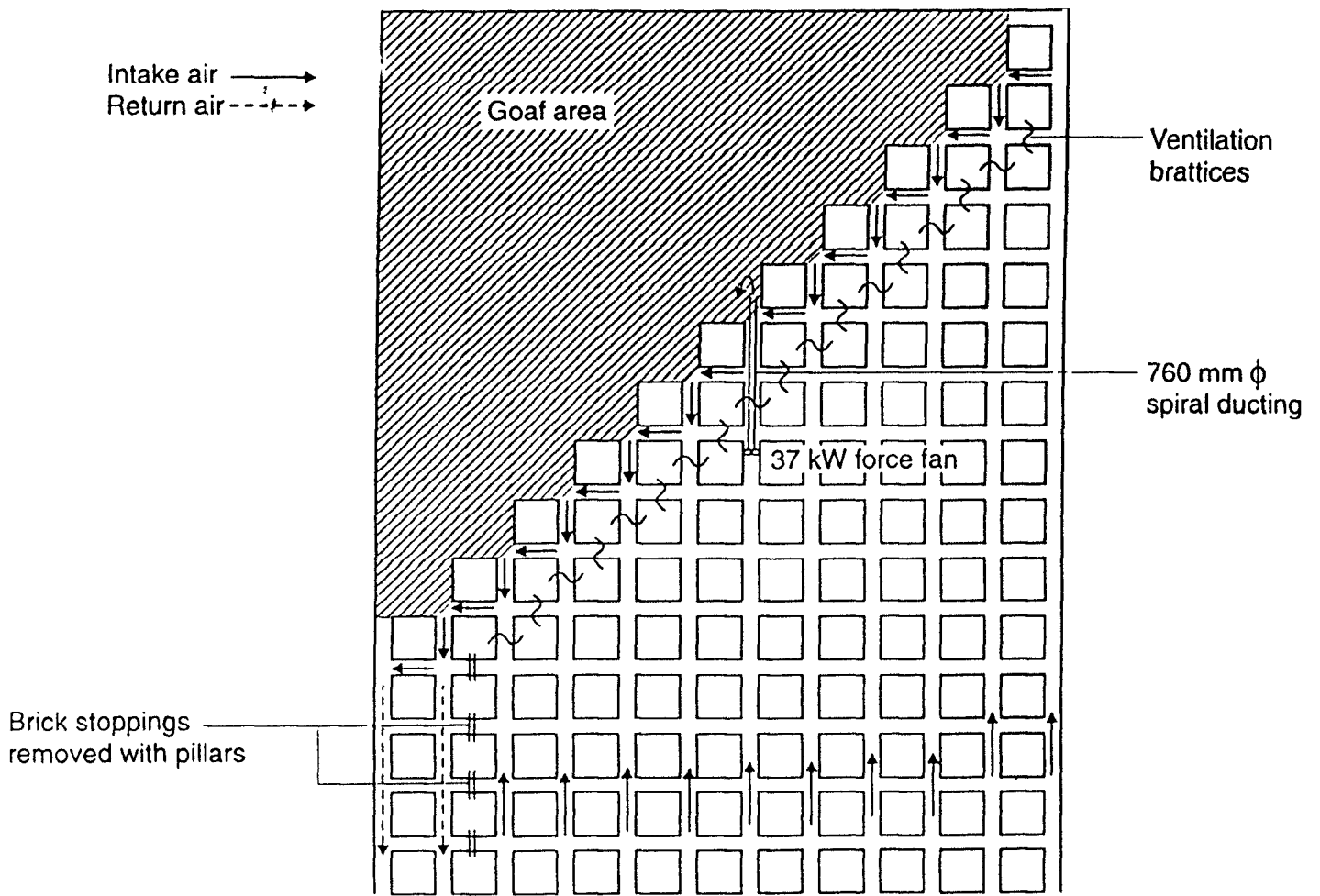

Figure 8 24 Pillars extracted in a 45 ° line with no bleeder road or 'over the goaf' system used

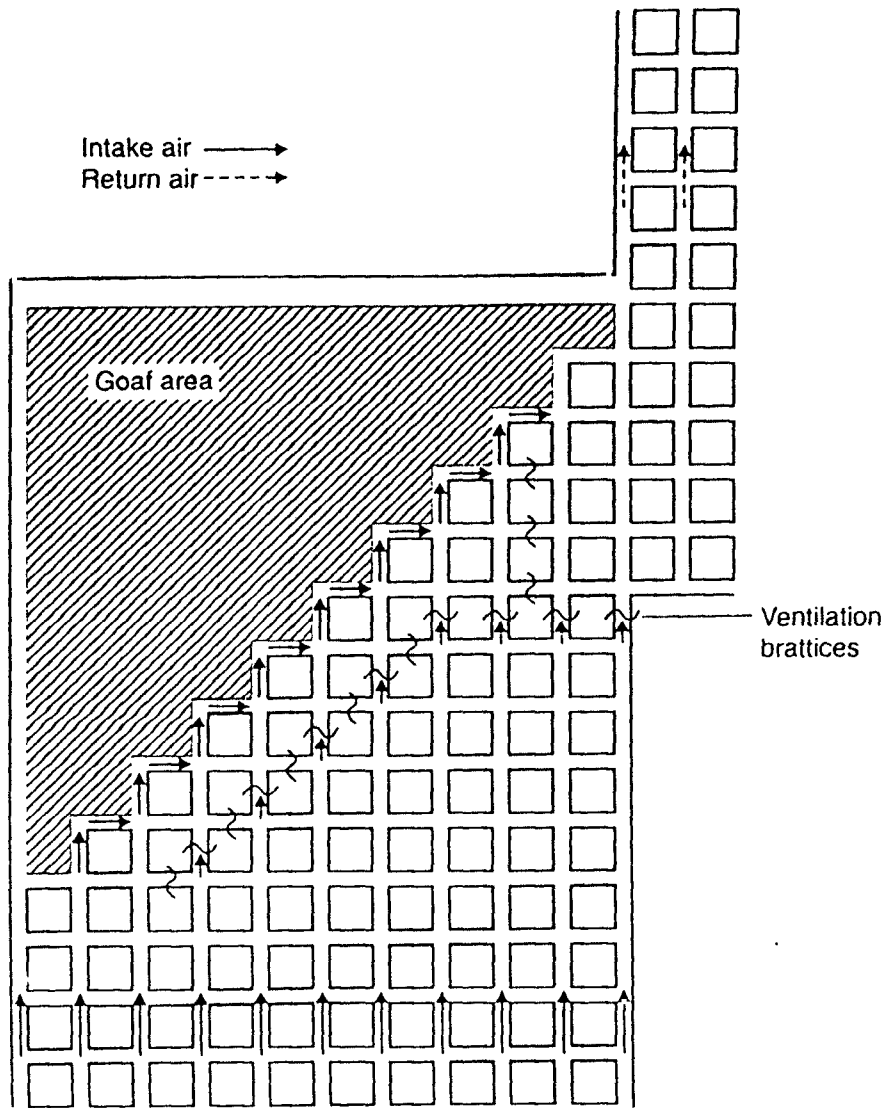

Figure 8 25 Pillars extracted in a 45 ° line, use is made of the return airway of an adjacent section

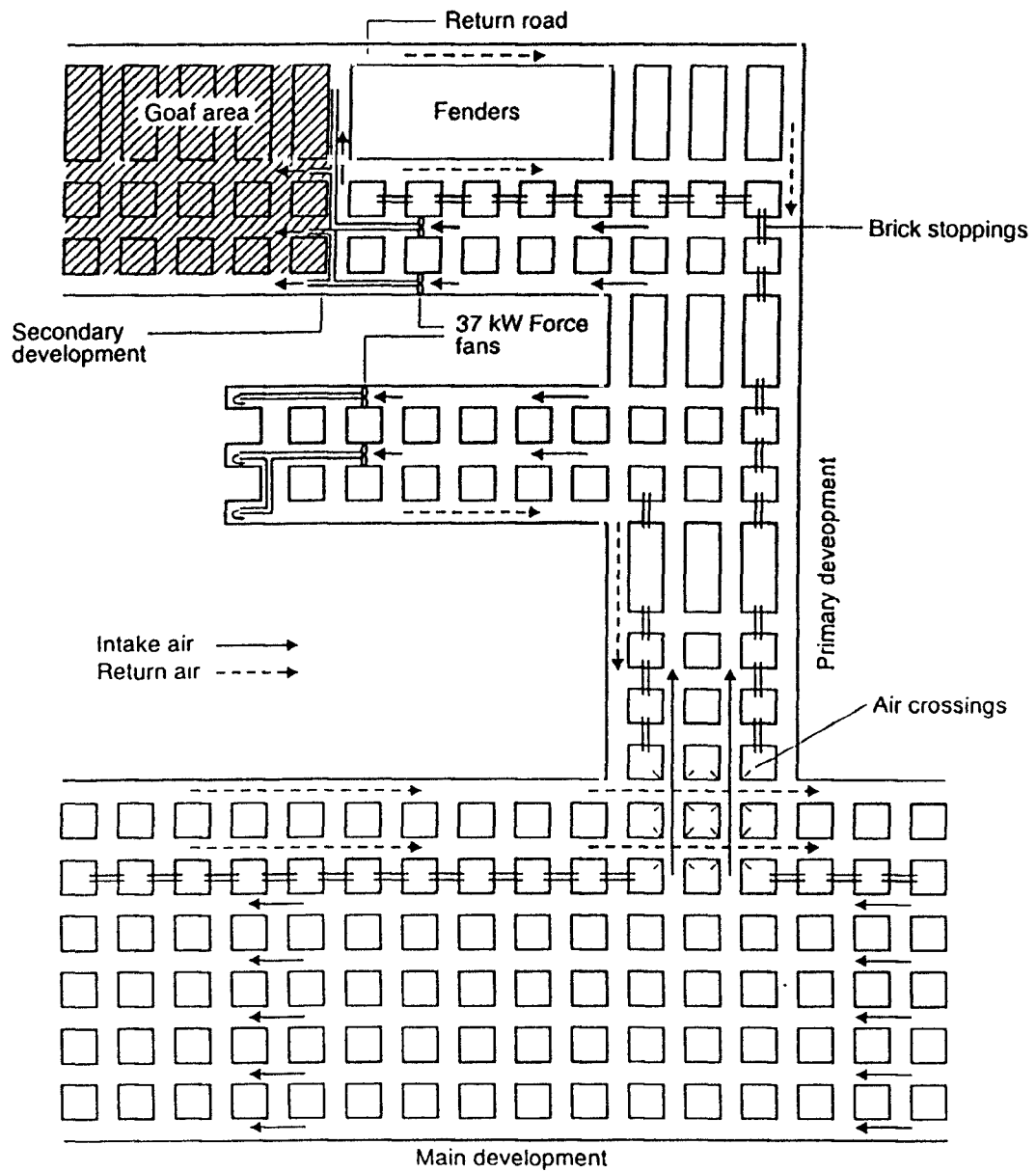

Figure 8 26 Rib-pillar extraction - ventilation layout during the development and extraction process

(ii) Another method is where primary development is done to expose a block of ground. Before the secondary development commences, two roads are developed at the top of the panel which would act as bleeder roads for the panel. The secondary development (four roads) now commences after which the tertiary development is carried out to

establish the ribs which are to be extracted (see Figure 8.27).

During the extraction process, air entered the panel via the intake roads and is coursed to the machine and position of cutting with air curtains. For the extraction process one of the return airways is converted into an intake airway and all the walls removed. All the air is concentrated to flow over the driver from where it flows through the goaf to the bleeder road, while some of it leaked back into the additional return airway (see Figure 8.28).

### 8.6.3 Discussion

As with the mining and extraction process of the pillars, there is no fixed method for ventilating stooping areas. Many of the methods used have evolved by trail and error and have been developed to overcome problems experienced with previous methods.

At present the various ventilation methods in use are designed around factors such as gas occurrences, geological conditions and mine layout. There are a few important aspects which need to be considered when a ventilation system is planned or used.

There are basically two methods of ventilation stooping sections, with the goaf ventilated or not ventilated.

#### (a) Over the goaf ventilation (bleeder road system)

The objective in using this method is to ventilate the goaf and to prevent any harmful gases from entering the section. A return airway is established at the back of the goaf which acts as a bleeder road for any gas present inside the goaf area. Difficulties which are experienced with this ventilation method include the following:

- (i) Establish a bleeder road either on the side or at the back of the goaf.
- (ii) The loss of mineable coal reserves, from having to keep pillars intact for the protection of the bleeder road.
- (iii) Restriction to airflow caused by extensive caving in the goaf area.
- (iv) Potential for spontaneous combustion in the goaf due to the low airflow rate through the caved area.

*The bleeder road system has the following advantages:*

- (i) The goaf is kept under constant pressure, preventing gas from entering the working area

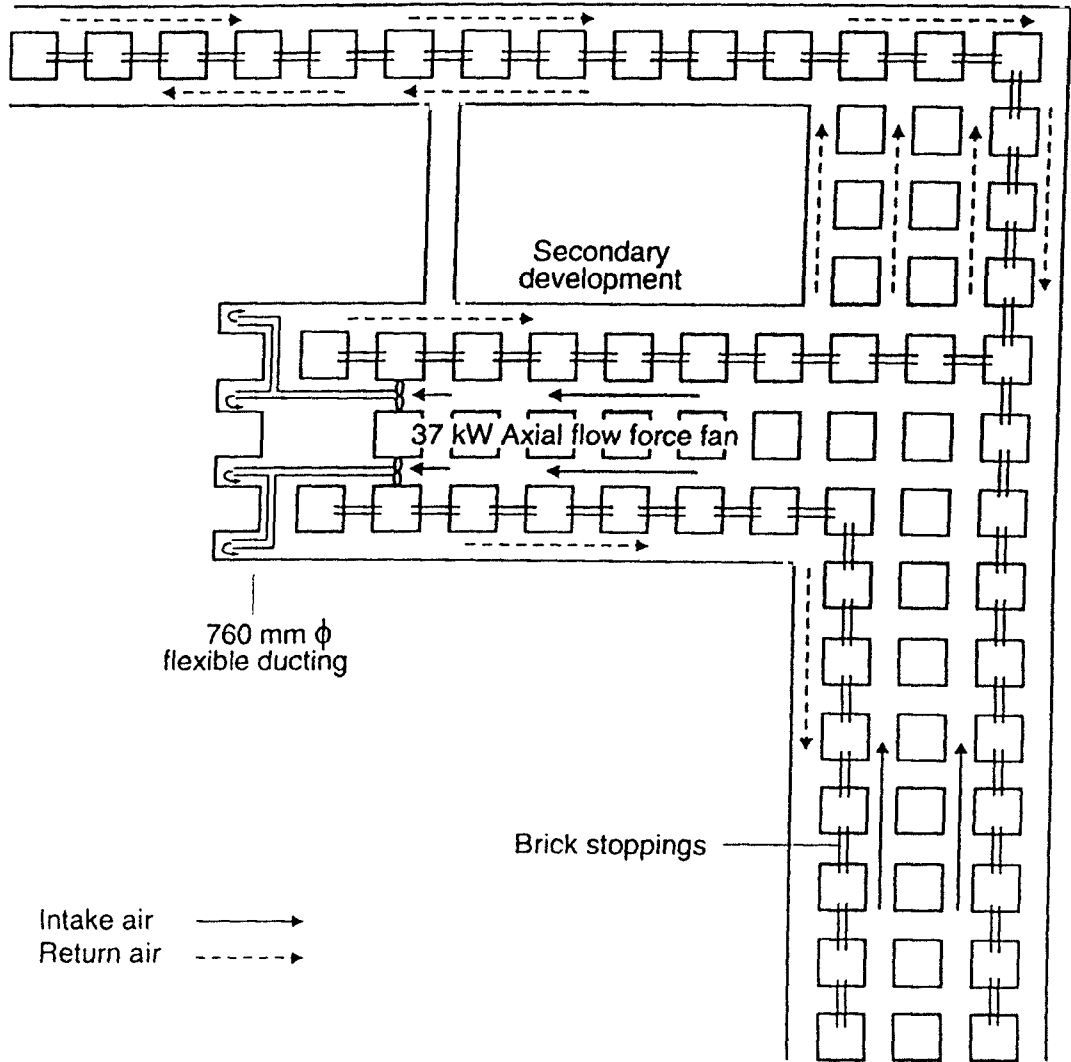

Figure 8 27 Ventilation layout during the development of the bleeder road, secondary and tertiary development for rib-pillar extraction

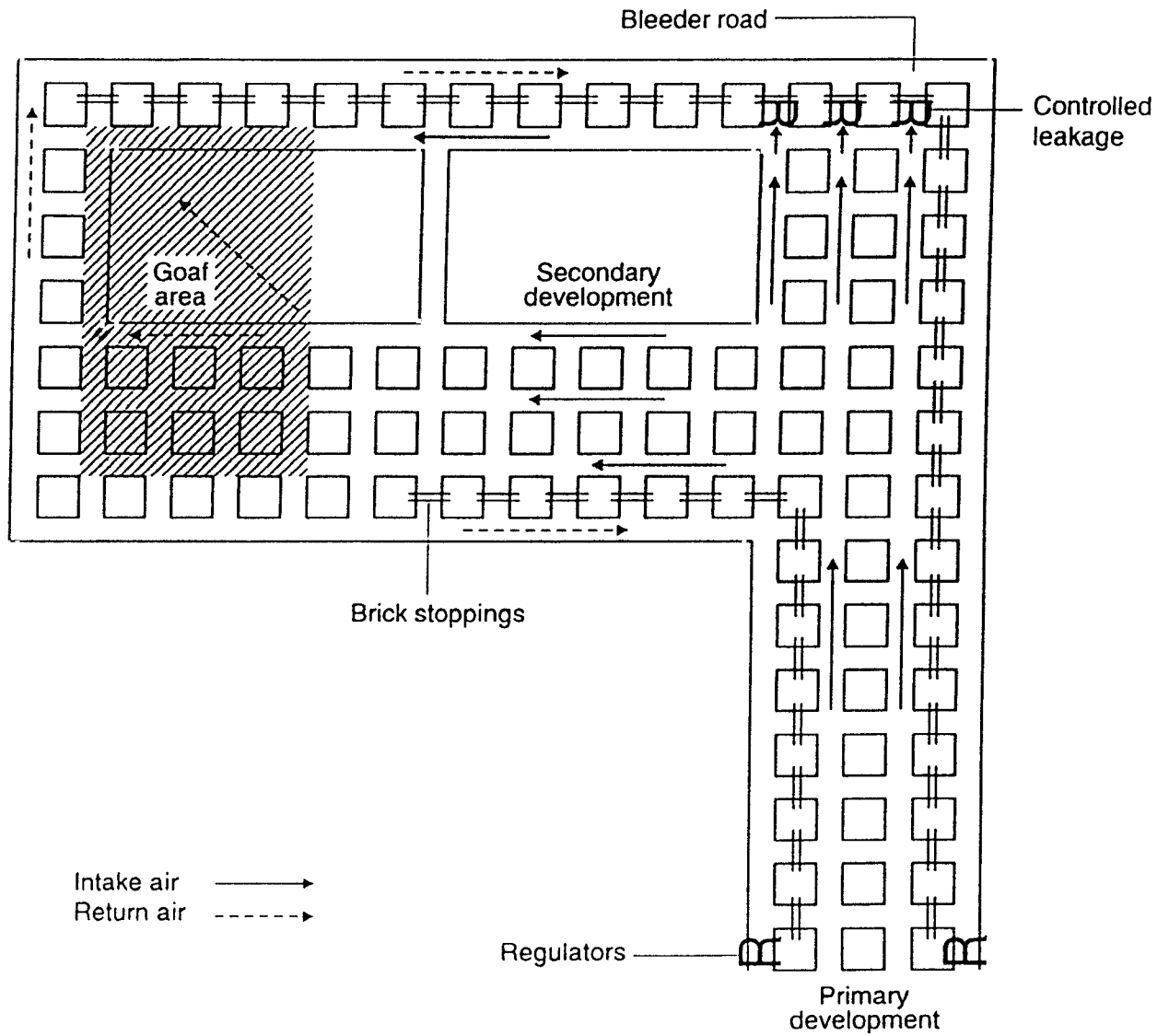

Figure 8 28 Ventilation layout for the extraction of the fenders during the rib-pillar development

- (ii) Fresh air is concentrated on the machine and all dust is removed into the goaf.
- (iii) Depending on the layout of the section/panel, substandard ventilation walls and structures do not influence face airflow to any great extent.

### **(b) No goaf ventilation**

For various reasons some mines prefer not to use the bleeder road system, including the possibility of spontaneous combustion in the goaf area. When not using a bleeder road or "over the goaf" ventilation, the air flows towards the cutting position in the intake airways, flowing in the LTR directly into the return airway. This method is fairly easy to execute, although it means ventilation walls must be kept up to date with the section, as a return airway is always required. Because of the number of roads involved, the air velocity in the LTR is still reasonably high and dust is removed effectively from the workers.

### **(c) Air Requirements**

The air quantities involved in this method of ventilation varies from mine to mine depending on individual circumstances. It is obvious that the more air is flowing through the goaf, the smaller the possibility of dust and/or methane related incidents in the goaf or section. However, not all mines have a considerable amount of air available for ventilating such a section, which means each mine uses its own criteria to determine the ventilation requirements. Methods used vary from the number of fans used during the development process, to using an approved formula to calculate the amount of air needed. Some mines even push in as much as possible with a minimum allowable quantity.

Whatever the method used, the following important aspects must be kept in mind when determining the ventilation requirements for any section:

- (i) Air quantities, utilization figures and air velocities must equal or exceed the requirements of the regulations as prescribed in the Minerals Act, or the standards set in the approved Codes of Practice.
- (ii) Ventilation conditions must create a healthy and safe environment for the workers in the section.
- (iii) The ventilation system must be easy to control. A system which is difficult to control, will result in no control at all.

For mines which prefer to use the bleeder road system of ventilation, there are certain considerations which should be kept in mind and included in the planning stage:

- The possibility of spontaneous combustion with the dangers of a coal dust explosion.
- The availability of an alternative return route in the event of the goaf closing up during extensive caving
- Advance planning for the establishment of a bleeder road or the utilization of the return road of an adjacent section.
- The installation of a continuous miner monitoring system in the return airways.

Mines which decide not to use the bleeder road system, should keep the following aspects in mind during the planning stage

- Good ventilation flow over the driver is essential to remove the dust into the goaf and the return airways
- Ventilation control must be well managed to ensure good ventilation flow.

## **9 THE USE OF COMPUTATIONAL FLUID DYNAMICS**

<b>9.1</b>	<b>Abstract</b>	<b>115</b>
<b>9.2</b>	<b>Introduction</b>	<b>115</b>
<b>9.3</b>	<b>Model Development for Mechanical Miners</b>	<b>116</b>
<b>9.4</b>	<b>Presenting the Simulation Results</b>	<b>119</b>
<b>9.5</b>	<b>Interpretation of Results</b>	<b>124</b>



## 9 THE USE OF COMPUTATIONAL FLUID DYNAMICS

### 9.1 Abstract

Increased use of continuous miners and road headers in the underground coal mining industry in South Africa has led to improved productivity and efficiency of operations. This advancement, however, has led to increased production of airborne dust during the operations. To be able to cope with this, ventilation methods, the correct utilization of these methods, as well as an understanding of the behaviour of airflow inside the mechanical headings has become extremely important for the ventilation practitioner and mine management.

Computational Fluid Dynamics (CFD) has been proven as an excellent tool to assist in evaluating ventilation systems and can in some instances also be used to identify and solve specific flow and system design problems.

This chapter reviews the application of CFD in evaluating and improving environmental conditions in mechanical miner headings, as well as providing a brief history of the development of the CFD model, and a discussion on a typical application.

### 9.2 Introduction

The flow of gases or liquids in general plays a very important role in many engineering processes. In order to assist in the design of processes or devices, it is necessary to understand the fluid dynamics involved and thereby to be able to deal with flow problems more effectively.<sup>1</sup> To obtain sufficient and meaningful data, theoretical and experimental methods are available. These methods are often costly and limited in the production of useful information, due to certain restrictions inherent in these methods, eg. the unavailability and limitations of experimental equipment.

CFD is rapidly becoming invaluable as a predictive and design tool and is fast, accurate, and cost effective. These computer simulations are often free from limitations imposed on analytical and experimental methods with the only limits to CFD being the speed and size of the computer, the time availability to solve the problem, and the ability to understand and model the situation, with its complex phenomena, accurately.

The main purpose of CFD is not to replace experimental work, but to provide information where it is dangerous or even impossible to perform experiments. It is also a very cost effective way to examine possible solutions to a problem, and it must be emphasised that the CFD practitioner is not normally a specialist in mining, general engineering, ventilation practices or in whatever field his expertise may find application. Interaction with the specialist in the field is of great importance to fully address the problem.

While it is meaningless to perform an experiment for each CFD simulation which is done, it is of great importance to validate the model from time to time. During the development of the basic CFD modelling tools, validation was done and the results published. During interaction with specialists in the mining field, there is a continuous monitoring of the correlation between the modelled and the actual situation.

It must be emphasised that CFD is not intended to replace experimental work, but rather gives direction towards more meaningful experimentation. CFD is of outmost importance in cases where the effects of changes can be modelled with greater speed and much less cost than in actual experimentation. The CFD model thus has an important place in the

design phase when the "what if" questions need to be asked.

Another point which needs to be emphasized is that the results of the modelling of airflow in mining sections must not be used to "measure" velocities or other quantities. The main focus must be on global evaluation and comparisons with other situations. It is also very dangerous to use the results of a certain situation and to extrapolate or deduct the results accurately for another "similar" situation. A problem often arises in the interpretation of results, as the only way to present results are in a two dimensional manner, although the model, as the real situation, is fully three dimensional. Care must always be taken when interpreting results, as this can very easily lead to misconception when the data is not seen in context and in conjunction with other means of data representation.

A number of CFD codes are available throughout the computer industry, but only a few of them have found an application into the underground mining industry. The STAR-CD model has been used quite extensively during recent years to simulate underground ventilation systems in mechanical miner headings. The results which were obtained thus far have been used with great success to better understand and evaluate the behaviour of airflow under various circumstances.

### 9.3 Model Development for Mechanical Miners

It was initially decided to develop the model for the continuous miner and roadheader in stages. The model began as a relatively simple structure and as confidence was gained in the value of the model, the complexity was increased. An important reason for this decision was that the model could easily be validated at each stage, to confirm the applicability for various situations.

From the beginning all the dimensions and parameters were identified and used in a FORTRAN-program to set up the solution mesh. This gives more flexibility when parameters change, for example the length of a heading, dimensions of the machine, as well as the positions of additional ventilation systems.

The first flow solution which was validated was the penetration of air into a heading in the case of no additional ventilation. The model was then used for an investigation of the combined and single effects of a forced column, exhaust column and brattice.

Once it was established that the modelled airflow patterns and velocities correlated with those found in experimental work, further development work was done. This included drum rotation, variation in the boom angle, spray systems, scrubber systems, the release of dust and methane, and the inclusion of jet fans and venturi sprays.

A CFD model is constructed in a number of steps. The first is to obtain the correct and complete geometry of the situation to be modelled. This three dimensional space is then divided into a finite number of cells. By using different shapes and sizes of cells it is possible to describe the complete geometry under consideration. Figure 9.1 shows the geometry of a roadheader (RH) model complete with on-board scrubber and with venturi sprays on the left side of the machine. The "dead" cells, as opposed to the "live" cells in which flow takes place, act as an obstacle in the flow field.

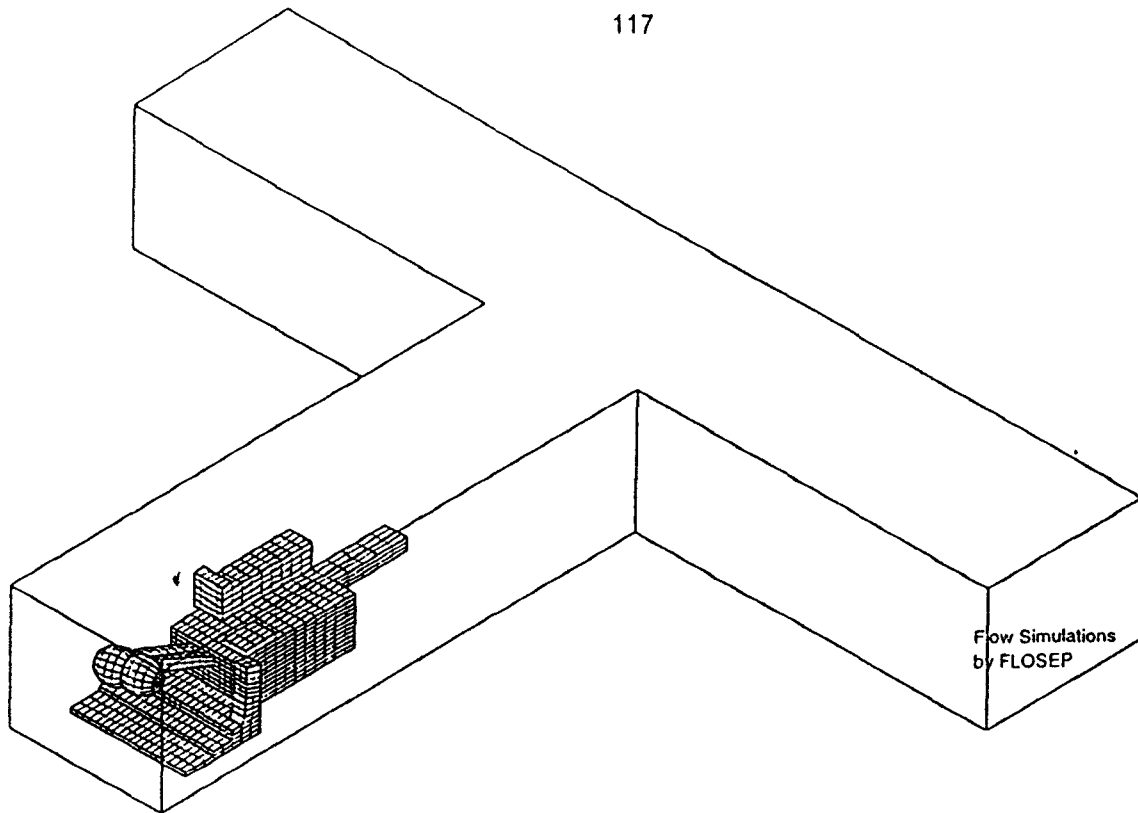

Figure 9.1 Geometry of a roadheader model

Figure 9.2 shows the geometry of a continuous miner (CM) with an on-board scrubber system. The continuous miner is also equipped with a directional water spray system.

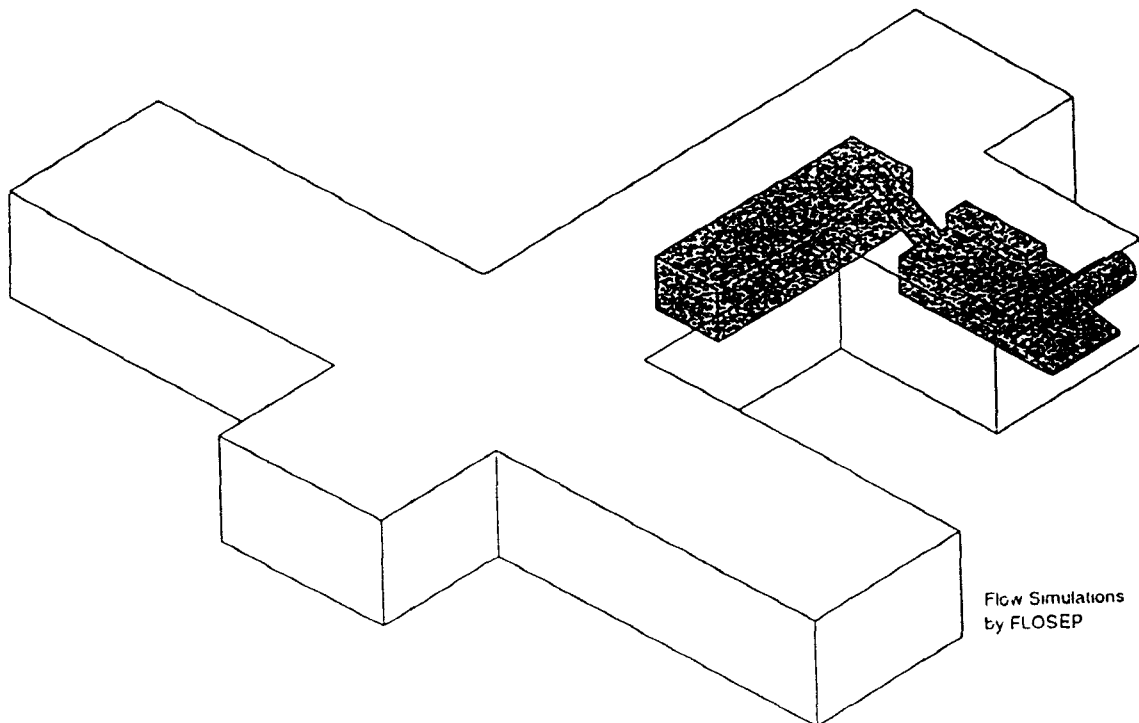
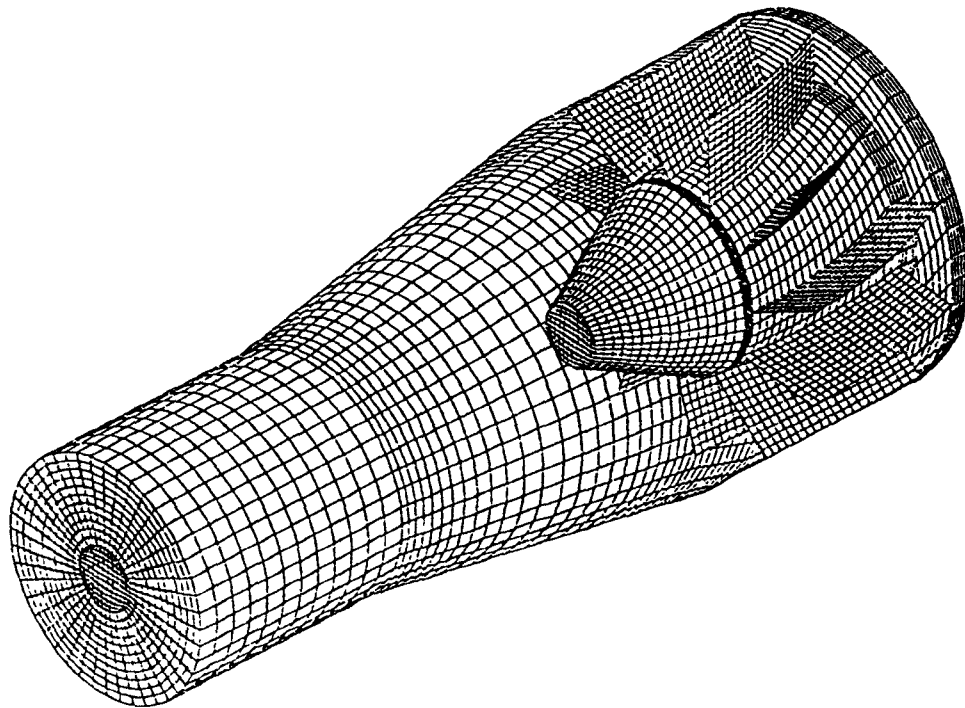

Figure 9.2 Geometry of a Continuous miner model

To take the construction of a model even further, different from the previous two geometries, the geometry can be more complex and detail orientated. An example is the simulation of the inside of a jet fan model, which requires more cells. Figure 9.3 shows the inside and outside of an airjet fan. This model was set up to obtain detailed boundary values for another model.



Flow Simulations  
by FLOSEP

Figure 9.3 Geometry of an airjet fan

The second step is to define the properties of the fluids involved in the problem. These include viscosity, density, temperature and other thermodynamic properties. Lastly the boundary conditions are defined. In the situation under discussion, this will include last through road (LTR) air velocities, volume flow of fans, on-board scrubbers, ventilation columns and air movers. Velocity components, pressures, and temperatures are specified at such boundaries.

Once the geometry and the properties of the flow situation are defined, the solution procedure can commence. This involves solving the continuity, momentum, and energy balance equations to obtain the three velocity components, pressure turbulent viscosity and temperature in each of the "live" cells, ie cells in which flow takes place.

The time it takes for the computer to complete the solution, is dependent on factors such as the complexity of the geometry, and the size and speed of the computer used. The companies who are using CFD are continually updating the software, as well as the equipment used to increase the speed of the solutions and to keep up with the latest technology on CFD

At the completion of the solutions the results must be interpreted. In order to do so, graphic representation is used. The solution is fully three dimensional, so the data can be presented meaningfully using slices through the geometry

## 9.4 Presenting the Simulation Results

There are different ways of presenting the results, depending on the purpose of the simulations and the detail which needs to be studied. Concentrating on airflow and dust concentrations, the results can be presented using Velocity vectors, Contours, Isosurfaces, and Dust particle flow lines.

### (a) Velocity Vectors

The velocity vectors are intended to show the direction of the flow, and to a lesser extent the size of the velocities, by their length. A far more accurate means of examining the sizes of air velocities is given by contours of velocity component magnitudes.

The velocity vectors are shown by using slices through the planes at different positions. These slices can be made through the horizontal planes as through the vertical planes of geometry (see Figure 9.4).

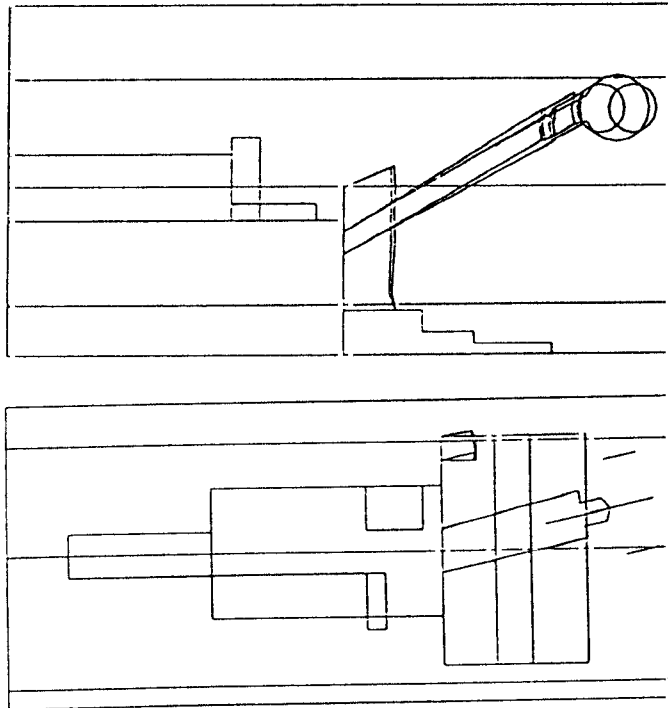
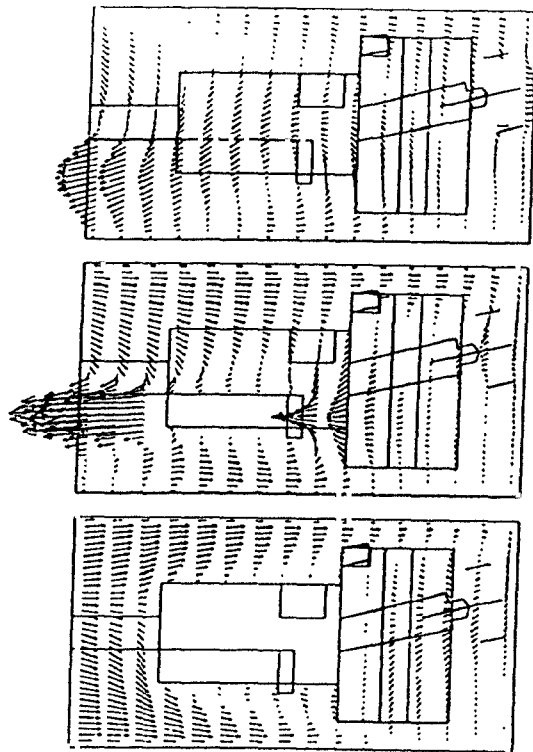

Figure 9.4 Position of horizontal and vertical planes for representing data

The arrows denote the direction and relative magnitude of the velocity at a given point. The larger the arrow, the greater the velocity and vice versa. The arrows assist in identifying recirculation areas, areas of low air movement, and so on. It is of great importance to remember that the velocity vector representation represents only velocity components in the relevant plane of the figure. The third component is not visible, though it presents, and has its influence on, the flow pattern. Care should thus be taken to deduce the flow pattern from a vector representation in a single set of planes only.

Vector plots are useful for comparing flow patterns, but care should be exercised when comparing velocity sizes, as the vector scales differ from case to case.



VELOCITY MAGNITUDE  
M/S  
LOCAL MX= 3 309  
LOCAL MN= 0.0000E+00  
\*PRESENTATION GRID\*

Flow Simulations  
by FLOSEP

Figure 9.5(a) Detail of velocity vectors on x-z planes in the vicinity of the machine

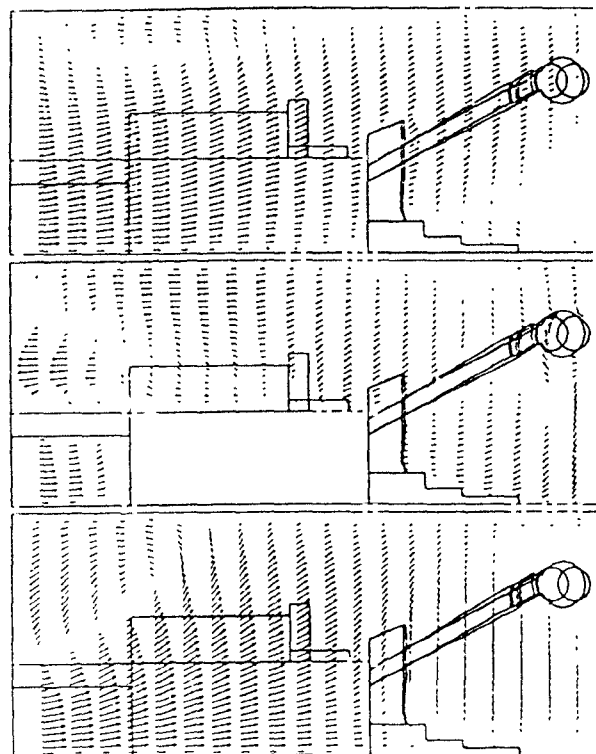

VELOCITY MAGNITUDE  
M/S  
LOCAL MX= 3 362  
LOCAL MN= 0 0000E-00  
\*PRESENTATION GRID\*

Flow Simulations  
by FLOSEP



Figure 9 5(b) Detail of velocity vectors on x-y planes in the vicinity of the machine

## (b) Contours

The solid contours in the contour plots represent regions in which the value falls between the values given in the key to the right hand side of the plot. Contour scales are usually chosen to give as much detail as possible. When comparing contours of different situations, care must be taken that the scales correspond.

Contours are sometimes more useful in determining the effect of a ventilation fan on the surrounding locations. The different shades of colour represent the different air velocities inside the model, and shows the actual distribution of the air for a particular scenario. By using the contours, it is possible to show the three dimensional behaviour of airflow by plotting the airflow in x-, y- and z- directions. Contours can be either colour (or shades of grey) contours or line contours.

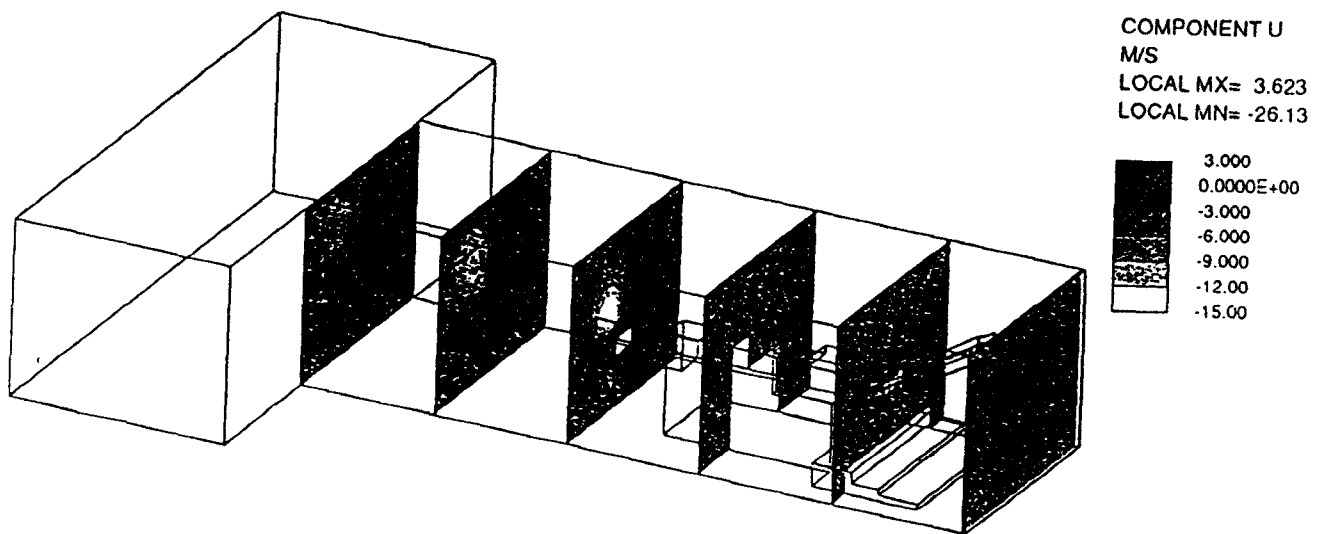

Figure 9.6 Examples of air flowing in the x-direction inside a heading

Contours can also be used to plot the behaviour of dust concentrations such as methane inside a heading. The range of the scale given can be chosen to reveal the amount of detail required. The methods used to define the properties of the contaminants into the program, and release them as part of the solution, are as follows:

(i) *Methane* From experiments and other measurements it is known what the influx of methane is at the face, as well as from the coal on the floor and the gathering arms. This boundary definition was added to the model and, in addition to all the other parameters ie the velocity components, pressure, density and turbulent viscosity, the concentration of methane can also be calculated as an integral part of the solution procedure.

(ii) *Dust* In the case of dust, the dust concentration at the face, as well as different positions on the machine, is known from measurements. The concentration value at the face is used to define a 'gas' whose concentration is known at the face. The gas

concentration is then calculated in a similar way to the methane concentration, except for the fact that this 'gas' is heavier than air and the gravitational effects act differently on the dust as opposed to the methane.

If one is interested in the flow from a jet fan or scrubber system, and the effects of recirculation, it is also possible to "mark" the gas from the jet fan or scrubber and then solve for the concentration of this gas as a "different" scalar, although the properties of this "gas" are exactly the same as the surrounding air. With this data available, it almost seems as if the flow from the jet fan or scrubber was made visible, and by studying the contours of the "marked" gas concentration a lot of information can be gained. It is sometimes referred to as marking the gas with another colour, but this is incorrect, as the colours in the contour graphs often vary through the whole spectrum of colours.

These plots can then be used to calculate factors such as recirculation, entrainment, effectiveness of the system, and so on.

### **(c) Isosurface**

An isosurface is, in a manner of speaking, a three dimensional contour. The flow in the simulations is three dimensional, and contours can only represent data in two dimensions. This means slices or planes must be chosen upon which to display data.

Another way of representing a scalar quantity is by means of an isosurface. If all the points at which a particular value occurs of a particular scalar, such a velocity magnitude, are collected, they must fall on a surface. An isosurface is simply a plot on this surface. In the case of velocity magnitude, all points inside this surface have a higher velocity than that chosen for display, and all those outside have a lower value. This rule of thumb, however, is sometimes complicated in cases where the airflow pattern is complex.

The use of an isosurface aids in the comparison of the penetration depth of different ventilation systems.

Figure 9.7(a) and (b) show an example where the air, flowing from a jet fan at a certain velocity, was plotted inside a heading. Figure 9.7 (a) shows the forward movement of the air and Figure 9.7 (b) shows the air flowing back from the face towards the LTR.



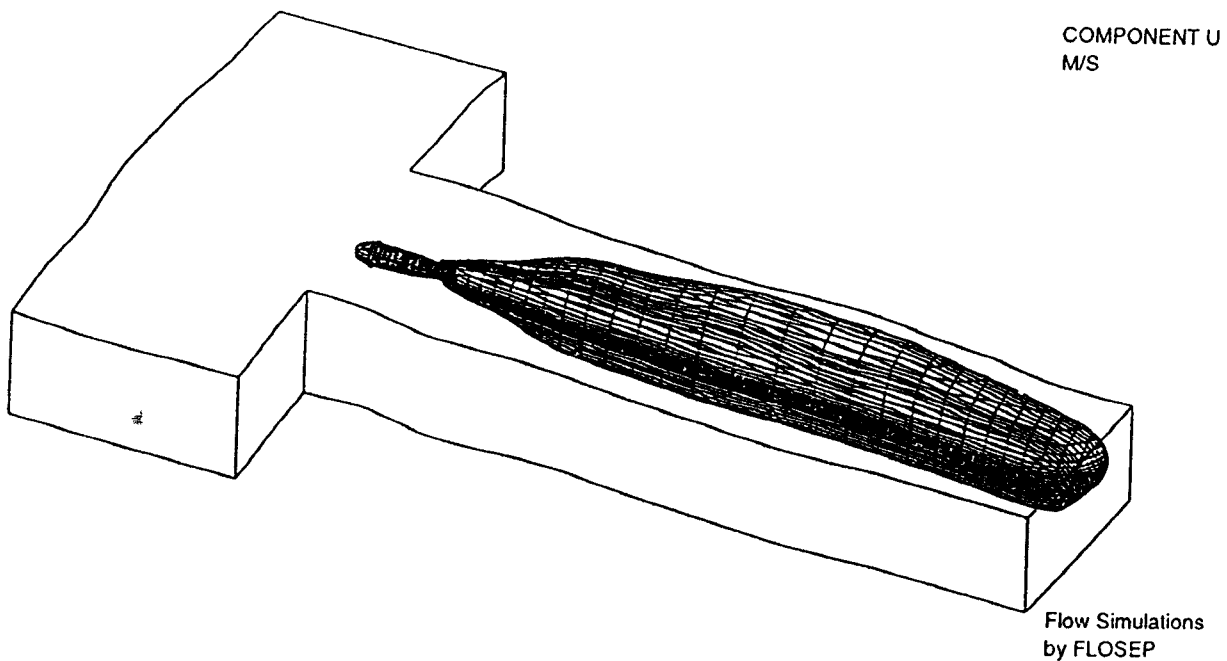

Figure 9.7(a) Isosurface showing the air from the fan flowing in a forward direction at a certain velocity

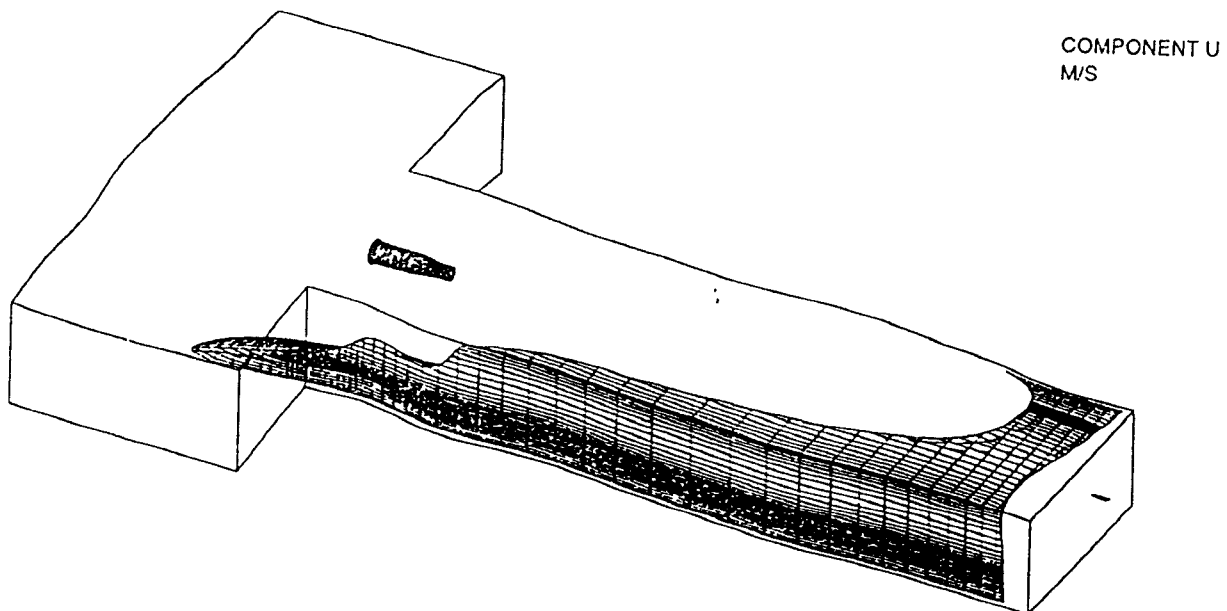

Figure 9.7(b) Isosurface showing the air from the fan flowing backwards from the face towards the LTR at a certain velocity

Under the assumption that respirable dust particles flow in the flow field, flow lines can also be used for a qualitative assessment of the movement of such particles. The different effects of ventilation systems and scrubber systems on the movement of these particles and the collection of these particles can then be assessed. The particles are released at any position or a number of positions inside the heading, from where the flow lines indicate the flow of the respirable dust particles.

To ensure that the path followed by the particles is indeed correct, a pilot study was made using a particle infrasizer, to determine the air velocities required to entrain coal particles of specific sizes under turbulent conditions. The data obtained was correlated with the results obtained from the CFD simulations.

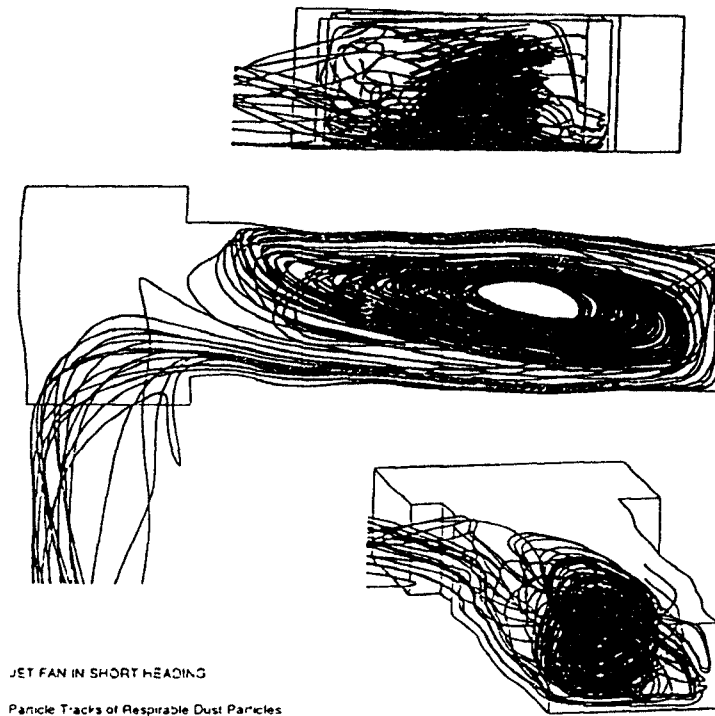

Figure 9.8 Flow lines indicating the flow of respirable dust particles

## 9.5 Interpretation of results

In order to be able to demonstrate the manner in which these results should be evaluated and interpreted, a hypothetical scenario with the solutions will be used as an example.

### (i) Scenario.

- A roadheader cutting a heading 20 m from the LTR
- Roadheader is fitted with a 75 kW wet scrubber delivering air quality of 12 m<sup>3</sup>/s
- No additional force ventilation is used in the solution
- The heading dimensions

- The scrubber efficiency is set at 94%
- The scrubber outlet is angled to deliver the air 10 degrees upwards and 0 degrees to the side
- The LTR air velocity is set at 1,0 m/s flowing from left to right past the heading
- The boom of the roadheader is cutting in the top left corner of the face with the drum rotating at 4 m/s
- Dust is being released around the cutting drum at 450 mg/m<sup>3</sup>
- A venturi air mover system is installed on the left side of the machine.

*(ii) Results required:*

- Determine the airflow behaviour and air velocity distribution with these systems in operation
- Determine the dust distribution as a result of the airflow conditions inside the heading.

*(iii) Presentation of the results:*

- Airflow vectors
- Air velocity contours
- Dust concentration contours.

*(iv) Evaluating Results:*

- Airflow Vectors

The airflow patterns and the flow of air into and out of the heading is best shown by the *airflow vectors*, also called the *arrow*. Three slices horizontally through the heading will be used to illustrate and explain what happens inside the heading. Figure 9.9, 9.10 and 9.11 show the airflow vectors at positions 0,75 m, 2,8 m and 4,1 m respectively.

At 0,75 m, which can also be identified as just above the gathering arms of the machine, the vectors show there is a big inflow of air into the heading towards the scrubber intake. It also shows this stream of air is being met by air from the face, which indicates the fresh air from the LTR is not reaching the face. The vectors at the other levels will prove this statement to be either wrong or correct. The vectors in the LTR indicates air is recirculating back into the heading, negatively influencing the airflow in the LTR (see Figure 9.9). This is because the LTR is shown to be closed off, which is not true in the real underground situation. The reader should not be alarmed by this and should ignore this phenomena as it will not effect the airflow inside the face area.

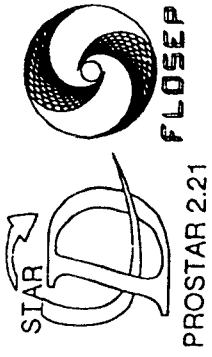

VELOCITY MAGNITUDE  
M/S  
LOCAL MX= 3.566  
LOCAL MN= 0.000E+00  
\*PRESENTATION GRID\*

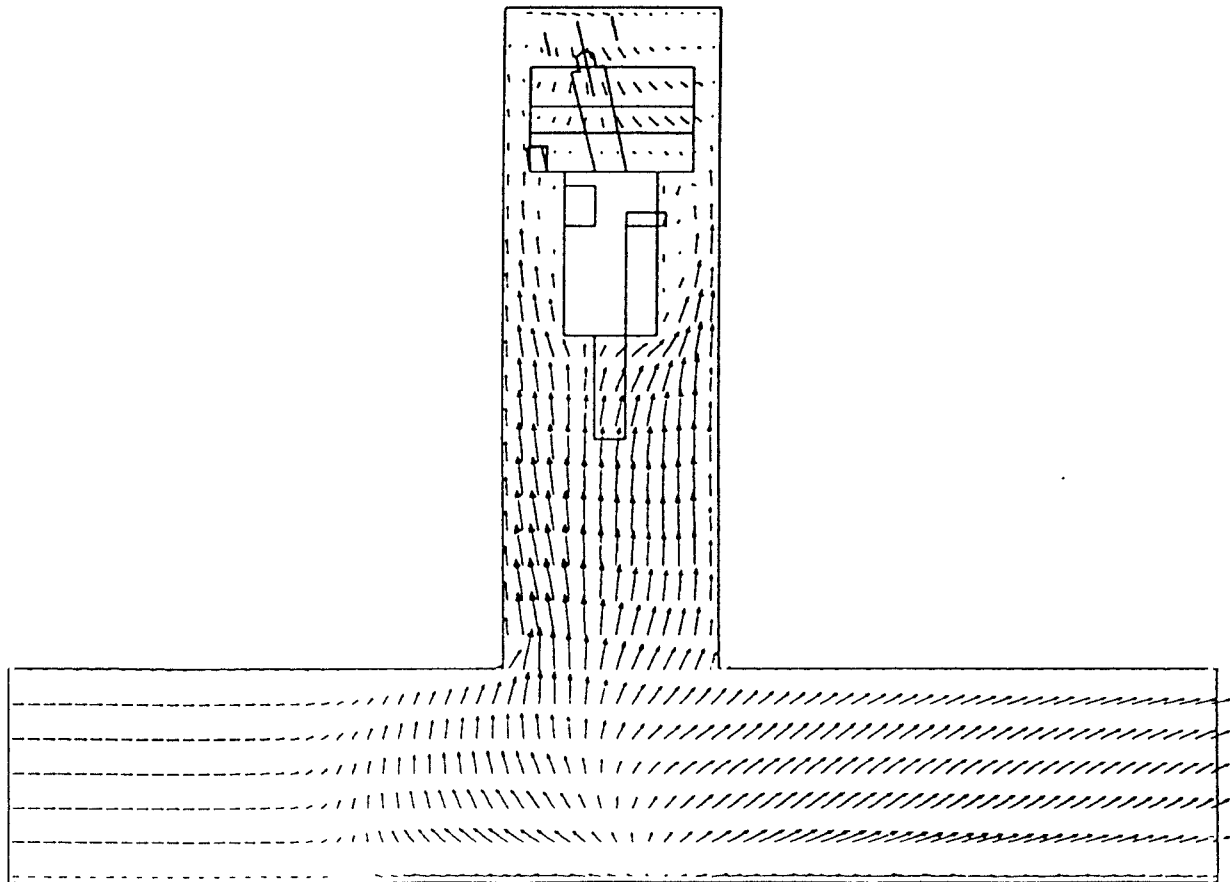

Flow Simulations  
by FLOSEP

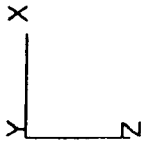

Figure 9 9 Velocity vectors at 0,75 m from the floor above the gathering arms

At 2,8 m, which is at operator height, the patterns are dominated by the air flowing from the scrubber. At this level there is a definite inflow of air from the LTR towards the face. From the face the air is flowing to the scrubber intake from where it is blown directly into the LTR (see Figure 9.10). The vectors show there is a fresh air supply to the face which proves the previous statement wrong. Because it is difficult to visualise the three dimensional flow of the air, the vectors plotted at separate levels should be studied together to understand where some of the vectors do start.

Higher up closer to the roof the next slice is given at 4,1 m, which is  $\pm 1,0$  m from the roof. At this level the vectors show complete recirculation behind the scrubber outlet. The reader must remember the outlet of the scrubber is pointing up to the roof at 10 degrees and the result is the airflow pattern as shown. Airflow is indeed present in the face area, but it is most probably air which is moving upwards from the lower levels, across the face and roof, towards the scrubber inlet (see Figure 9.11).

This is not the only manner in which these vectors can be displayed. The arrows, which were shown above, only demonstrate the flow of air on the horizontal plane. What about the vertical movement of the air in the face area? They must also be studied to understand the behaviour of the vectors on the horizontal plane. Figure 9.12 shows the vertical movement of the arrows at positions on the right hand side (RHS), centre (C) and on the left hand side (LHS) of the machine.

On the RHS of the machine, air is shown to be flowing upwards, towards the roof, with some turbulent airflow patterns at the back of the machine.

In the centre of the machine, arrows show there is mainly movement back from the face over the roadheader. Underneath the machine at the back, there is a small inflow of air.

On the LHS of the machine there is mainly an inflow of air towards the face, with turbulent levels underneath the cutting boom and against the roof.

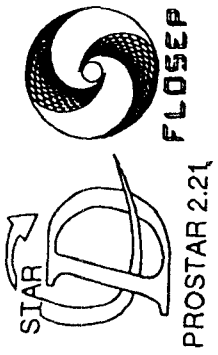

VELOCITY MAGNITUDE  
M/S  
LOCAL MX= 26.53  
LOCAL MN= 0.0000E+00  
\*PRESENTATION GRID\*

Flow Simulations  
by FLOSEP

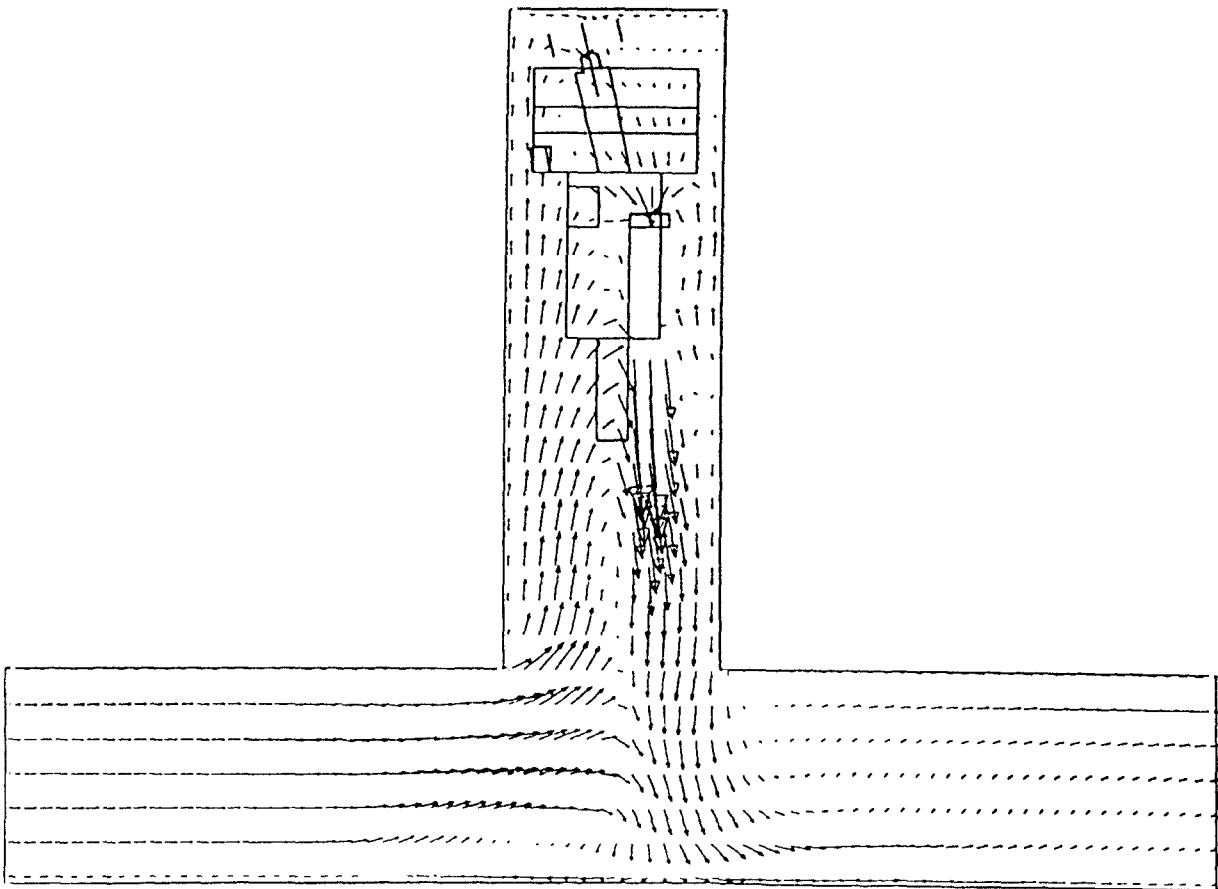
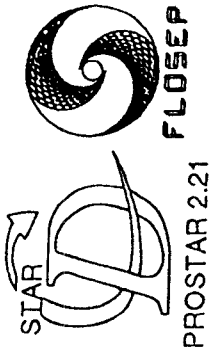

Figure 9 10 Velocity vectors at 2,8 m from the floor at operator level



VELOCITY MAGNITUDE  
M/S  
LOCAL MX= 3.362  
LOCAL MN= 0.0000E+00  
\*PRESENTATION GRID\*

Flow Simulations  
by FLOSEP

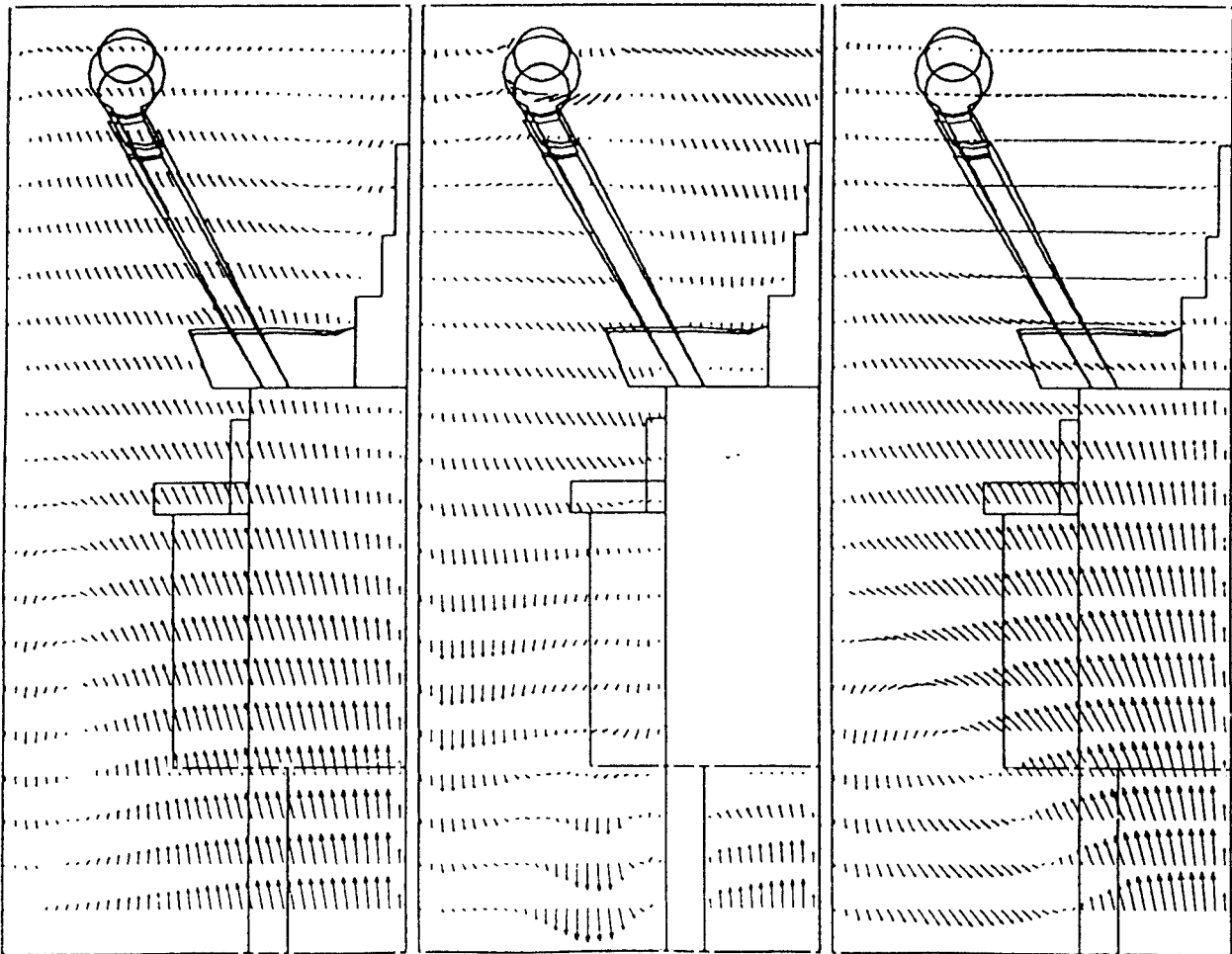
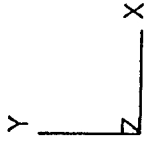
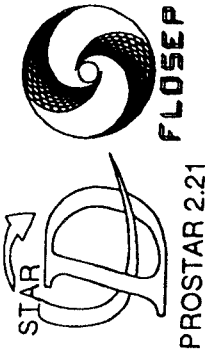

Figure 9 11 Velocity vectors at 4,1 m from the floor, just below the roof



VELOCITY MAGNITUDE  
M/S  
LOCAL MX= 9.413  
LOCAL MN= 0.0000E+00  
\*PRESENTATION GRID\*

Flow Simulations  
by FLOSEP

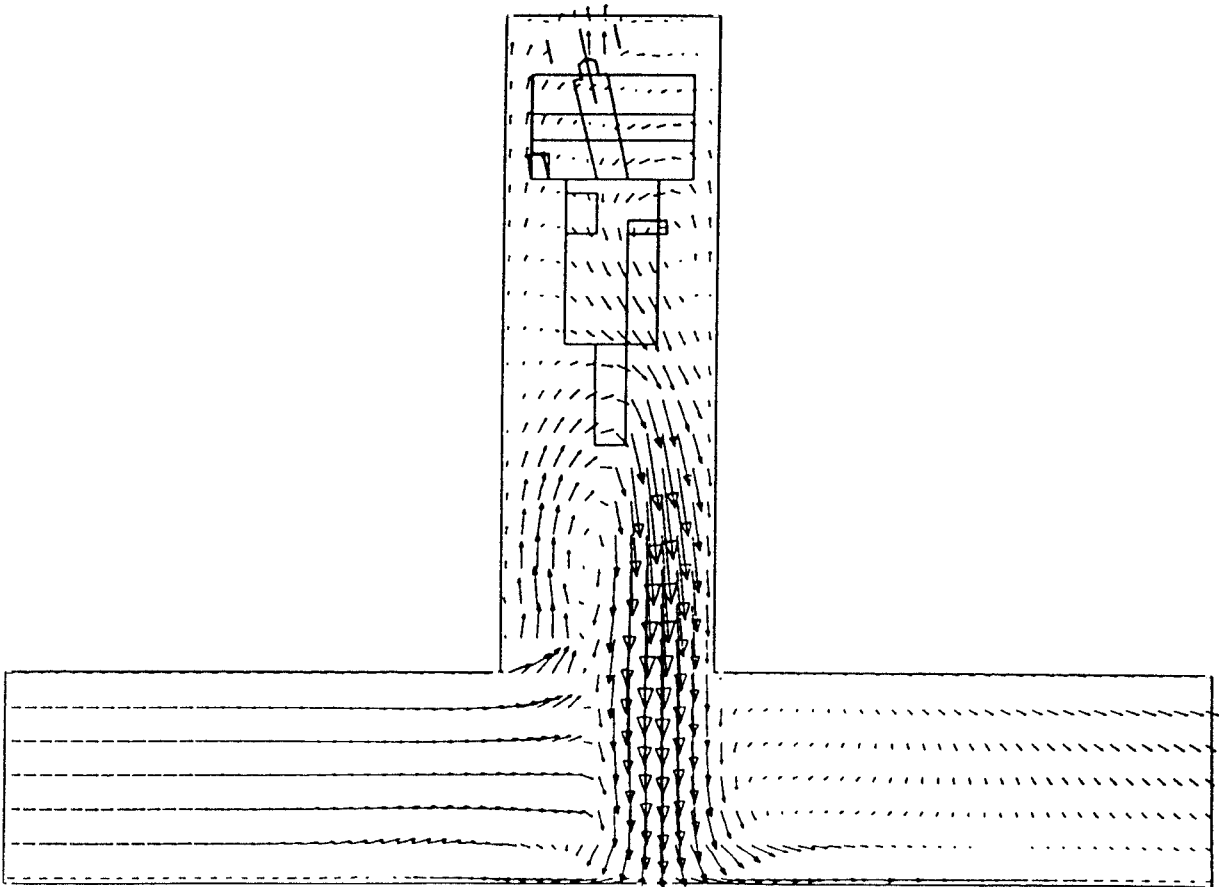
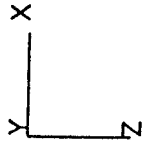

Figure 9 12 Velocity vectors showing the vertical movement of the air around the machine



- Air Velocity Contours

Normally these contours would be given in colours, but for the sake of this publication, the prints are given in different shades of grey for ease of copying. It is sometimes, however, difficult to differentiate between the different shades of grey and therefore the contours are also presented in the form of line contours with A, B, and C values which represent the different air velocities.

The arrows which were discussed and shown, are excellent in forming an idea of the direction of airflow and the prevailing flow pattern. To get closer to understanding the three dimensional flow phenomena and to be able to put values to the vectors, the use of contours are the best suitable option.

At a certain seam height, the airflow in a heading changes from two dimensional to three dimensional. Effectively this means that the air moves in six different directions at one particular spot. This is best illustrated by using vertical contours at regular intervals through the heading. The computer is capable of giving contours which show the flow of air in these different directions. They are called flow in the x-direction, y-direction and z-direction.

The flow of air in the x-direction means the air is moving directly forwards and backwards on the length of the heading. The flow of air in the z-direction means the air is flowing from sidewall to sidewall across the heading. The flow of air in the y-direction means the air is flowing up and down inside the heading, in other words from the roof to the floor and vice versa. This all happens at the same position and therefore the x-, y- and z-directions are plotted separately.

Figure 9.13 (a) shows the airflow contours for the air flowing in the x-direction, which means forward and backward movement. Figure 9.13 (b) shows the same printout but with the line contours. To understand whether the air is flowing into the heading or out of the heading, the values on the legend must be studied. All the positive values on the scale indicates the flow of air in a forward direction towards the face.

*The negative values on the scale indicate a flow in a negative direction, or in a backward direction towards the LTR, and not a negative air velocity. High areas of in- and outflow of air can now be studied.*

COMPONENT U  
 M/S  
 LOCAL MX= 3.623  
 LOCAL MN= -26.13

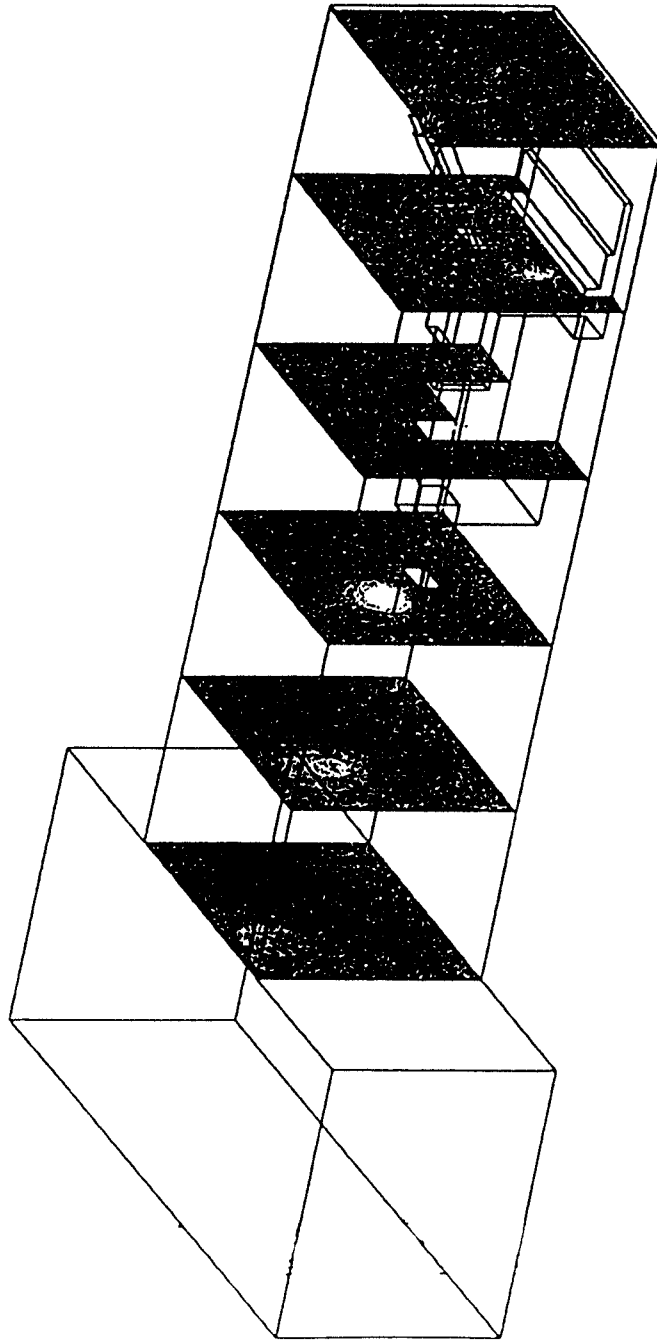
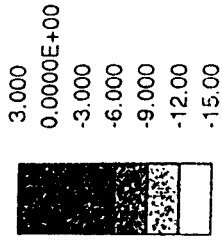

Flow Simulations  
 by FLOSEP

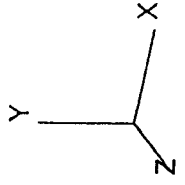
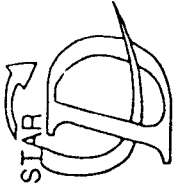

Figure 9 13(a) Velocity contours showing the airflow in the x-direction



PROSTAR 2.21

COMPONENT U  
M/S  
LOCAL MX= 3.623  
LOCAL MN= -26.13

	A	B	C	D	E	F	G	H	I	J
4.000										
2.000										
0.0000E+00										
-2.000										
-4.000										
-6.000										
-8.000										
-10.00										
-12.00										
-14.00										

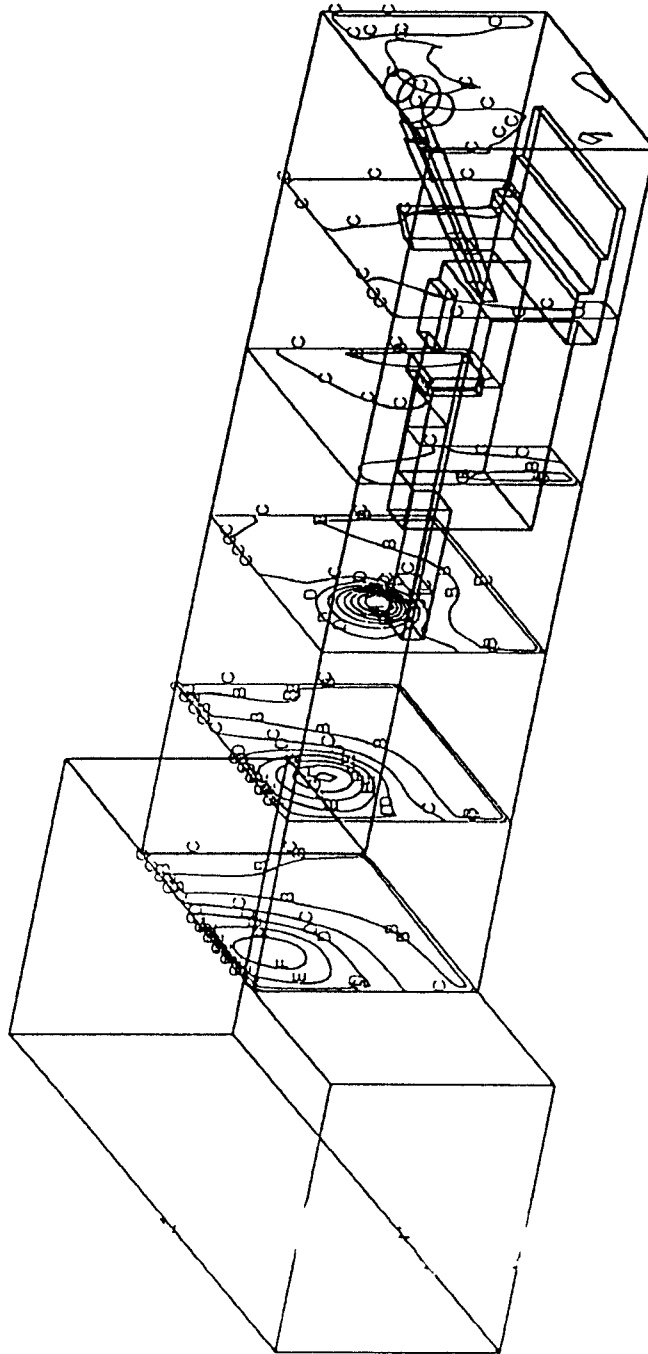

Flow Simulations  
by FLOSEP

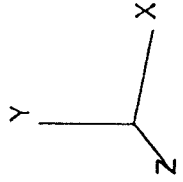

Figure 9 13(b) Line contours showing the airflow in the x-direction

Figure 9.14 (a) shows the airflow contours for the air flowing in the y-direction, which means the up and down movement of the air from the roof to the floor and vice versa. See Figure 9.14 (b) for the line contours. Again the values on the scale should be studied to understand the direction of the air. Throughout the heading not many air movements in these directions are shown. On the face, however, the contours show a downward movement against the face at velocities of up to 3,5 m/s. This is caused by the falling coal particles, the rotation speed of the drum and the effect of the water sprays on the cutting head. This zone of air movement is unfortunately very small.

To get the full picture, Figure 9.15 (a) for the colour contours and Figure 9.15 (b) for the line contours, should also be studied. These printouts give the direction of the air in the z-direction or in other words, the movement of the air from side to side. These particular printouts, together with the printouts showing airflow in the x-direction, are the most meaningful ones to study. This sideways movement shows whether air is sweeping the face, and in what direction across the face. This gives an indication of the effectiveness of the ventilation system used, as well as the effectiveness of a sprayfan system, if in use on the machine.

These pictures show that hardly any air movement is present on the face from side to side. The contours show the values are between +5 m/s and -5 m/s which can be practically zero velocity. This indicates an area which needs improvement in the front of the machine, and that the directional venturi system in use on this roadheader should be upgraded. In the rest of the heading air movement is present, but only at low velocities, and there is no fixed flow pattern.

#### - Dust Concentration Contours

For this particular problem, the dust concentrations will be displayed using different shades of grey contours. This gives the reader an indication of the distribution of the dust as a result of the prevailing ventilation system. The contours should be studied in conjunction with the airflow vectors in order to understand the behaviour of the dust. Factors which influence the behaviour of the dust, includes air velocities, position of the cutting head, positions of water sprays and air movers, and the influence of the on-board scrubber on the air movement.

COMPONENT V  
 M/S  
 LOCAL MX= 4.605  
 LOCAL MN= -3.809

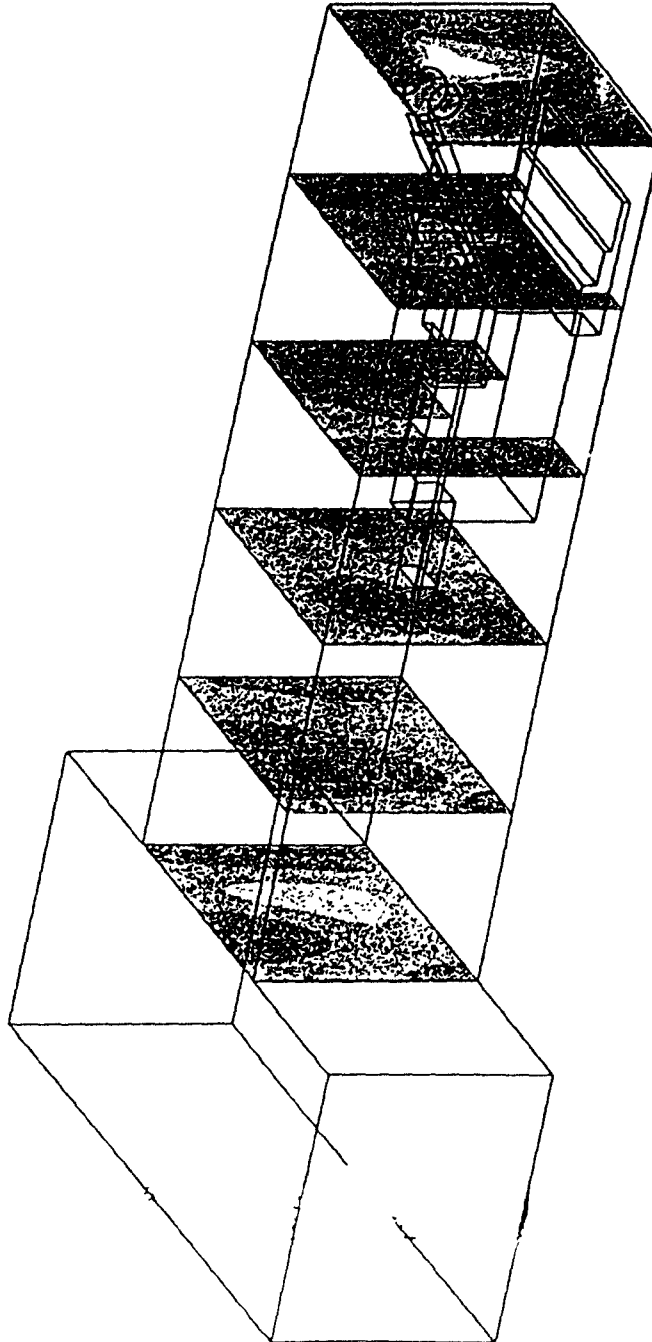
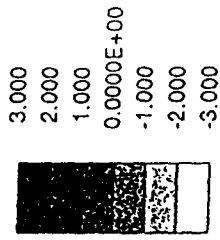

Flow Simulations  
 by FLOSEP

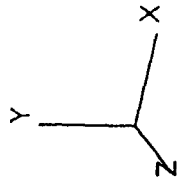
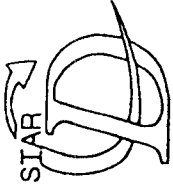

Figure 9 14(a) Velocity contours showing the airflow in the y-direction.



PROSTAR 2.21

COMPONENT V  
M/S  
LOCAL MX= 4.605  
LOCAL MN= -3.809

A	3.000
B	2.400
C	1.800
D	1.200
E	0.6000
F	0.2086E-06
G	-0.6000
H	-1.200
I	-1.800
J	-2.400
K	-3.000

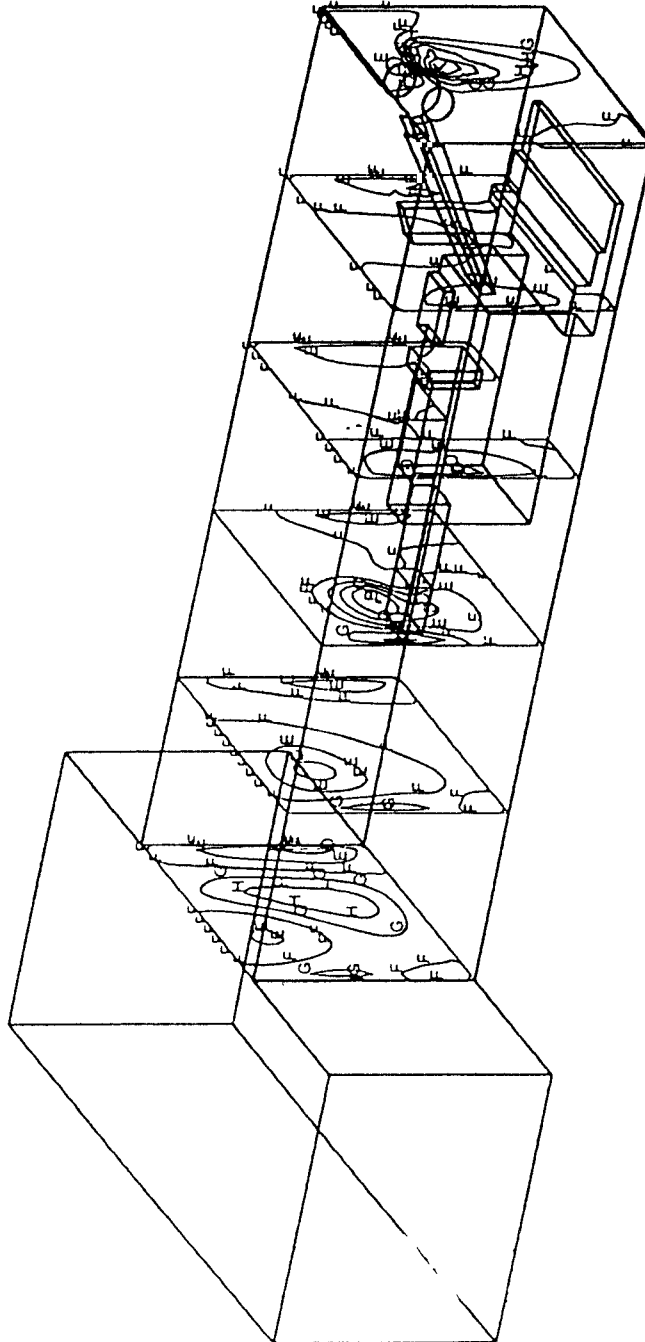

Flow Simulations  
by FLOSEP

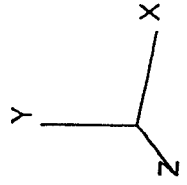
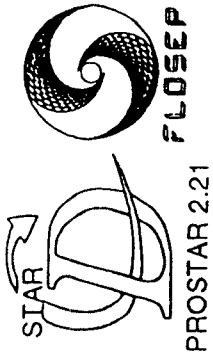
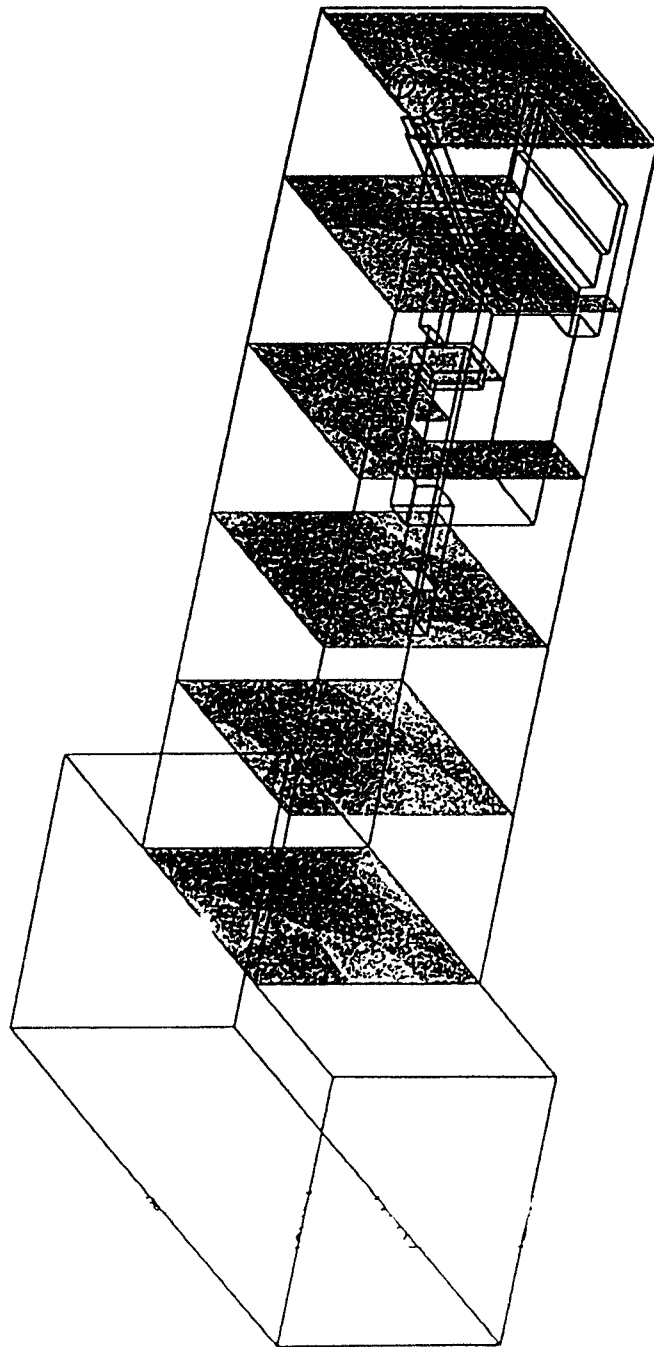
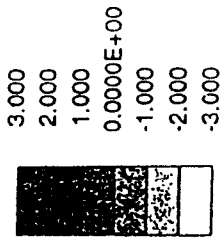

Figure 9.14(b) Line contours showing the airflow in the y-direction



COMPONENT W  
 M/S  
 LOCAL MX= 4.412  
 LOCAL MN= -3.725



Flow Simulations  
 by FLOSEP

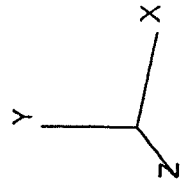
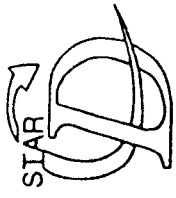

Figure 9 15(a) Velocity contours showing the airflow in the z-direction





PROSTAR 2.21

COMPONENT W  
M/S  
LOCAL MX= 4.412  
LOCAL MN= -3.725

A	3.000
B	2.400
C	1.800
D	1.200
E	0.6000
F	0.2086E-06
G	-0.6000
H	-1.200
I	-1.800
J	-2.400
K	-3.000

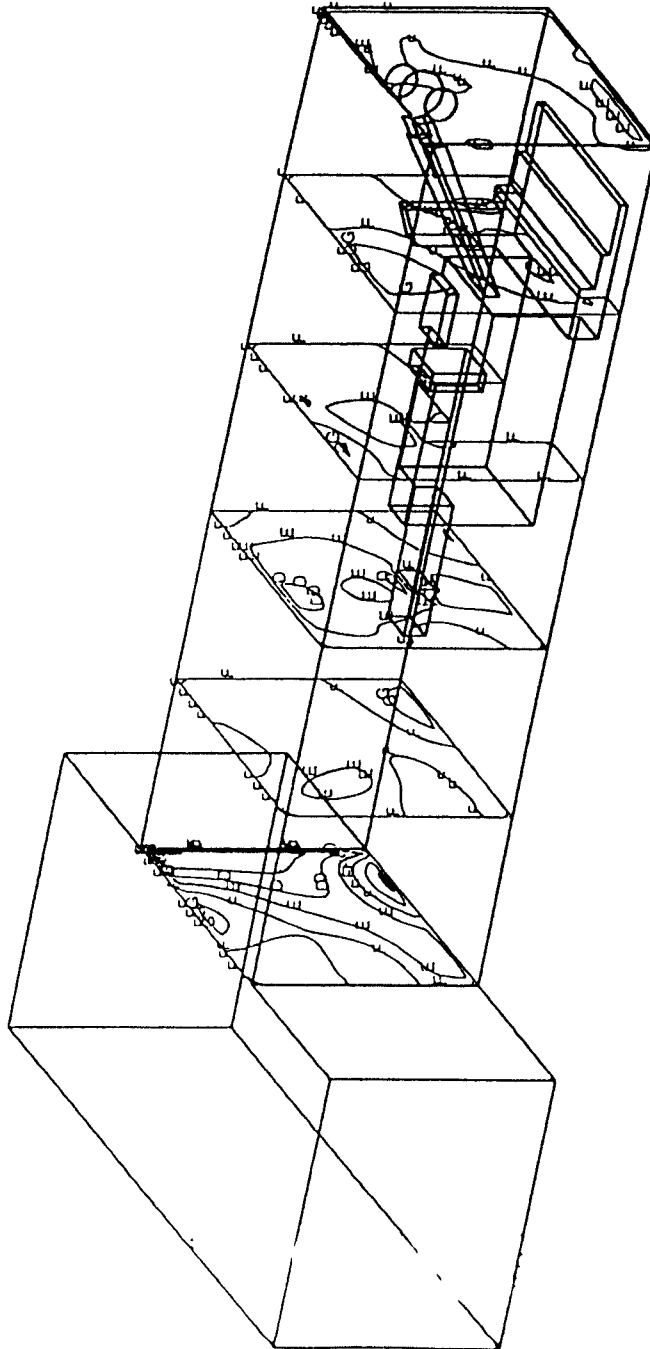

Flow Simulations  
by FLOSEP

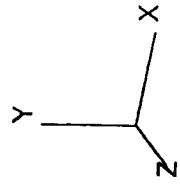
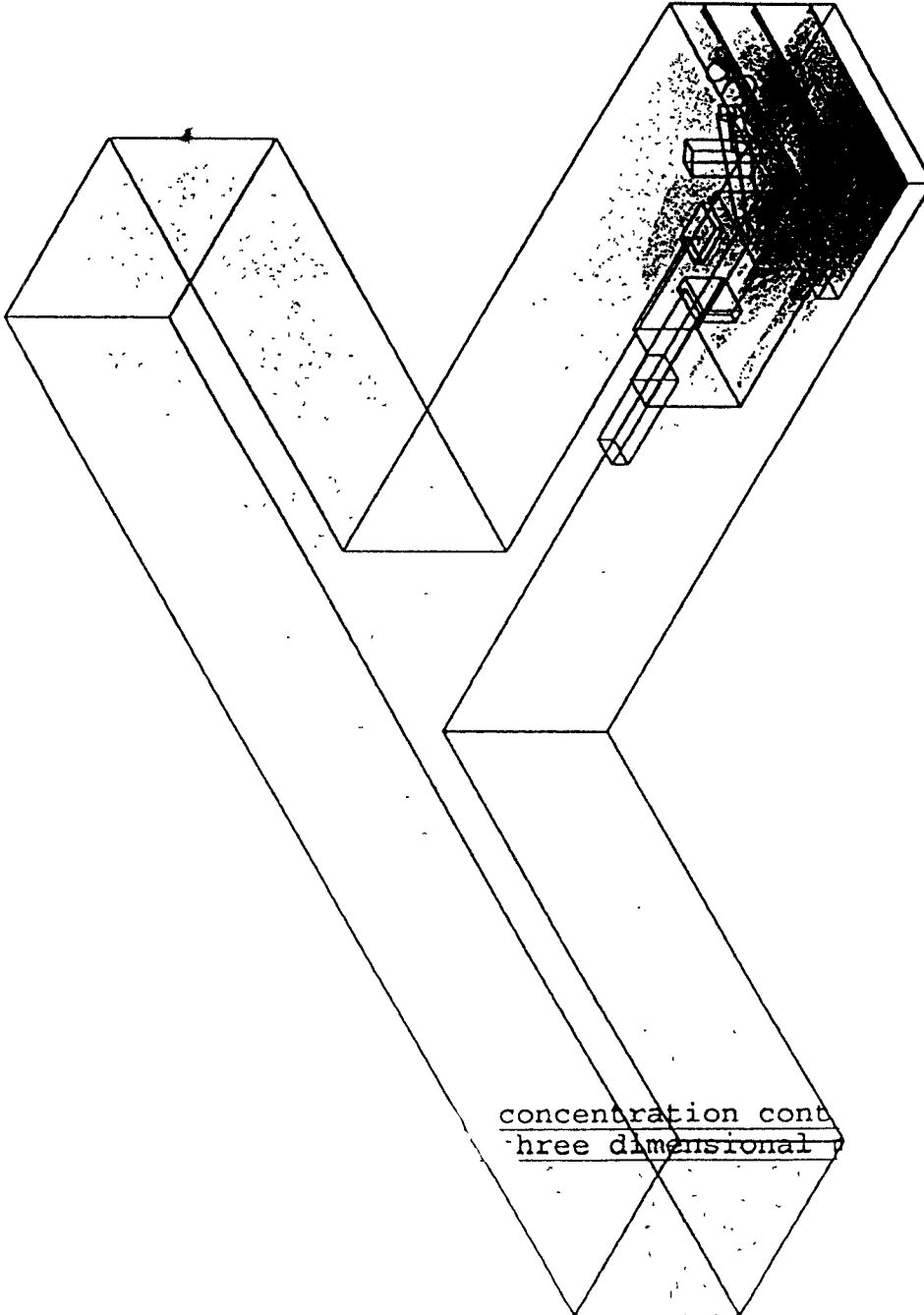
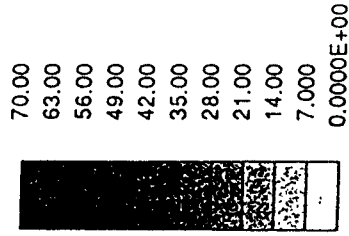

Figure 9 15(b) Line contours showing the airflow in the z-direction

Figure 9.16 shows the distribution of the dust in a three dimensional manner which enables the reader to visualise the conditions around the roadheader. The contours show good control of the dust from the left side of the machine to the scrubber side. The colours indicate low dust values, which in turn indicate the dilution of the dust is effective, and only low concentrations of dust is present in the vicinity of the driver. By studying results presented in this manner, it is possible to evaluate the effect of ventilation systems on dust and to identify areas where airflow seems to be a problem.

The use of CFD to evaluate the performance of ventilation systems, with particular regard to dust and airflow behaviour, is cost effective and saves time. The detail in which results are given is much more extensive than could be achieved with underground experiments and the results enable the manager to better understand the prevailing conditions in the working headings.

DUST CONCENTRATION  
 mg/cub m  
 LOCAL MX= 450.0  
 LOCAL MN= 1.125



Flow Simulations  
 by FLOSEP

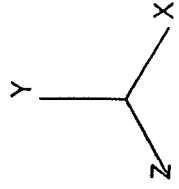

Figure 9 16 Dust concentration contours presented in a three dimensional manner

## REFERENCES

### Chapter 2

1. Hinds, W.C. Properties, Behaviour and Measurement of Airborne Particles. Aerosol Technology.
2. Guidelines for the gravimetric sampling of airborne particulate for Risk assessment in terms of the Occupational Diseases in Mines and Works Act no. 78 of 1973. Supporting document 2, second edition Nov 1992, p 2/2
3. Roepke, W.W. et al. 1976. Reduction of dust and energy during coal cutting using point attack bits. USBM RI 8185, pp 53.
4. Ramani, R.V. et al. 1987. Fundamental studies on the relationship between Quartz levels in the host material and the respirable dust generated during mining. Volume I Exp., Results and Analysis. A mining Research Contract Report #H0358031, USBM.
5. Reiser, M.T.R. and Robock, K. 1977. Results of epidemiological, mineralogical and cytotoxicological studies on the pathogeneity of coal-mine dusts. Inhaled Particles 4 (edited by Walton W H). Pergamon Press, Oxford, UK, pp 703-715.
6. Occupational diseases in mines and works Act no 78 of 1973
7. Thorne, P.S. et al. 1985. Physicochemical characterization of cryogenically ground, size separated, fibrogenic particles. Environ. Res. 36, pp 89-110.
8. Koskinen, H.A. et al. 1983. Increased prevalence of HLA-AW19 and B18 in advanced silicosis. Chest 83, pp 848-852.
9. Novier, M.H. et al. 1980. Role of family susceptibility, occupational and family histories and individual blood groups in the development of silicosis. Br. J Ind. Med. 37, pp 399-404.
10. Raask, E. and Schilling, C.J. 1980. Research findings on the toxicity of quartz particles relevant to pulverized fuel ash. Ann. Occup. Hyg. 23, pp 147-157.
11. Reiser, K.M. and Last, J.A. 1979. Silicosis and Fibrogenesis: Fact and artifact. Toxicology 13, pp 51-72.
12. Cartwright, J. 1967. Airborne dust in coal mines: The particle - size - selection characteristics of the lung and the desirable characteristics of dust sampling instruments. Inhaled particles and vapours II, London, pp 393-406
13. Environmental Engineering in South African Mines. MVS of SA 1982, Chapter 28, pp 763-771.
14. Zipf, R.K. and Bieniawski, Z.T. 1986. Fracture mode and loading rate influences on the formation of respirable size fragments on new fracture surfaces. Proc. of the International Symposium on Respirable Dust in the Mineral industries. October, pp 81-87.
15. Khair, A.W et al. Correlation of dust due to regrinding at the face. WV 15/USBM 5421.
16. Tsai, C.J et al. 1987. Fragment size distribution from simple fracture of coal and rock. Annual meeting of the American Association of Aerosol Research, Seattle.
17. Xu L and Mutmansky, J.M. 1990 Analysis of physical, chemical and Mineralogical characteristics of airborne coal mine dusts Proc of the 3rd Symposium on Respirable Dust in the Mineral Industries, pp289-297

18. Organiscak, J.A. et al. 1990. Sources and characteristics of quartz dust in coal mines. Proc of the 3rd Symposium on Respirable Dust in the Mineral Industries, pp 319-328.
19. Chiang, A.S. et al. 1984. Some factors influencing the airborne dust distribution in longwall face area. Proceedings of the Coal Mine Dust Conference, Morgantown, October.
20. Wang, W. et al. 1990. Analysis of respirable dust distributions with multiple dust sources on longwall faces. Proc of the 3rd Symposium on Respirable Dust in the Mineral Industries, pp 367-375.
21. Bhaskar, and Ramani R.V. 1988. Dust flows in mine airways: A comparison of experimental results and mathematical predictions. SME-AIME Annual Meeting, January.
22. Mutmansky, J.M. et al. Establishment of standard procedures for characterization of respirable coal mine dust potential. PS5/USBM 4205.
23. Ramani, R.V. and Shankar S. Prediction of ambient dust concentration in mine atmospheres. PS2/USBM 4202.
24. Ramani, R.V. et al. 1987. Fundamental studies on the relationship between quart levels in the host material and the respirable dust generated during mining. Report on USBM Contract H358031, September, pp 179, (Volume 1) and pp 90 (volume 2).
25. Environmental Engineering South African Mines. MSV of SA 1982, Chapter 15, pp 381.
26. Gibson, H. and Vincent, J.H. 1980. An investigation of 'fly-dust' nuisance in mines. Proc. 2nd Int. Mine Ventilation Congr., Reno, NV, 620-2.
27. McPherson, M.J. Subsurface Ventilation and Environmental Engineering. Chapter 9, p 310
28. McPherson, M.J. Subsurface Ventilation and Environmental Engineering. Chapter 19, pp 743 - 744
29. Walli, R.A. (1982). Mine dusts. In Mine Ventilation and Air Conditioning (ed. Hartman), Chapter 5, pp 84 - 130
30. McPherson, M.J. Subsurface Ventilation and Environmental Engineering. Chapter 20, p 765.
31. Flagan and Seinfeldt, p23

#### Chapter 4

1. Du Plessis, J.J L. 1994. Airborne dust in a longwall face. July.
2. Guidelines for the Gravimetric sampling of airborne dust and fume concentrations at Gold Mines. October 1989, GME 16/3/2/2/9/1
3. Guidelines for the Gravimetric sampling of airborne Particulates for Risk Assessment in terms of the occupational diseases in Mines and Works Act no 78 of 1973. Supporting Documentation no. 9, April 1991, GME 16/2/3/2/3.
4. Sullivan, P 1985 Hund operating instructions. T M Data Editon, February, p 2.
5. Hinds, W C Aerosol technology, John Wiley and Sons, Chapter 10, p 187-194.